

HDM16216H-B

Dimensional Drawing

16 Character x 2 Lines, Connector on Bottom

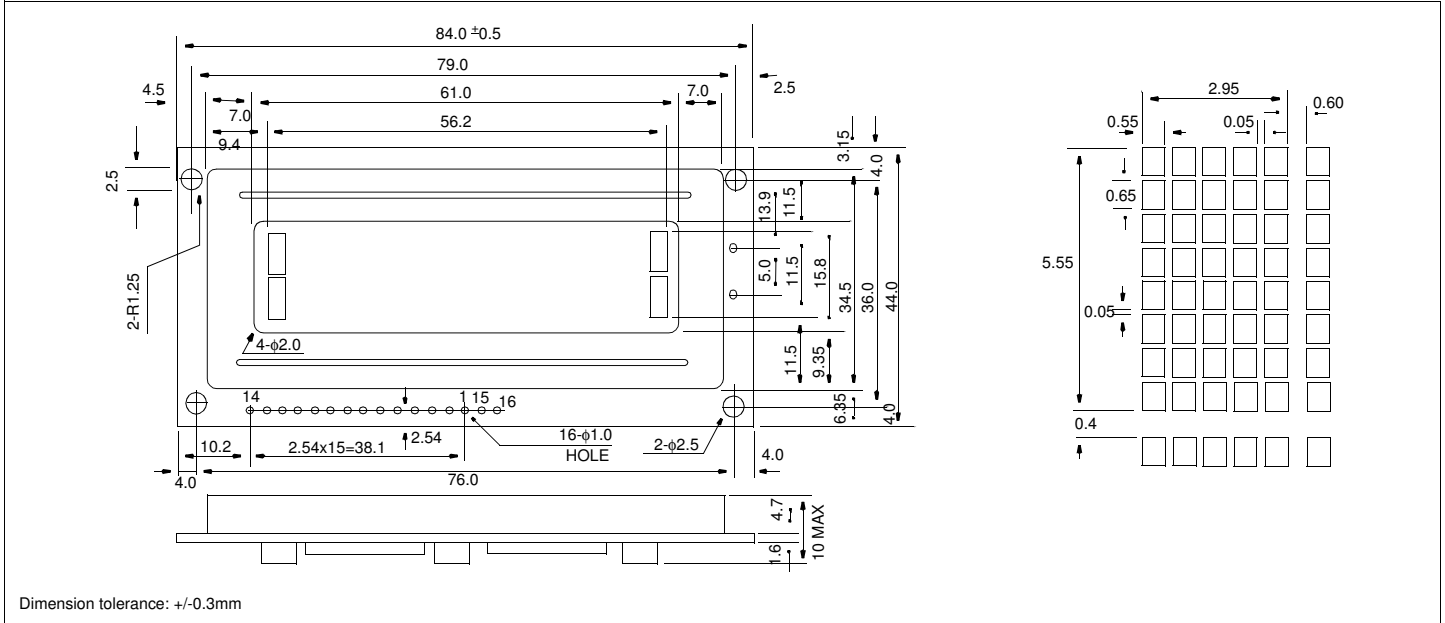

Features

Character Format5x7 Dots with Cursor
 Backlight.....EL Optional
 Options....TN/Gray STN/Yellow STN, 12 o'Clock/6 o'Clock View
 Normal/Extended Temperature
 Normal/Negative Displays

Physical Data

Module Size.....84.0W x 44.0H x 10.0T mm
 Viewing Area Size.....61.0W x 15.8H mm
 Weight.....34g

Block Diagram

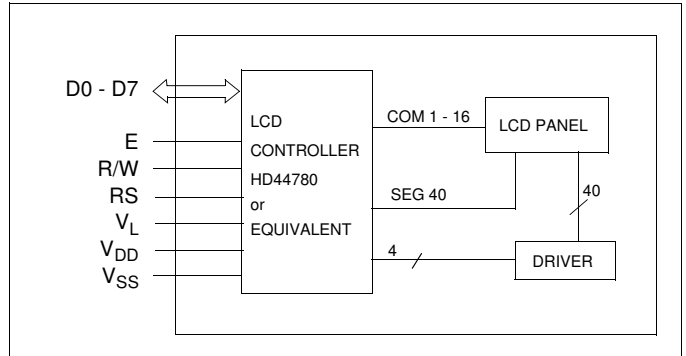

Absolute Maximum Ratings

| PARAMETER | SYMBOL | MIN | MAX | UNIT |
|------------------------|-----------------|----------|----------|------|
| SUPPLY VOLTAGE | $V_{DD}-V_{SS}$ | 0 | 7.0 | V |
| SUPPLY VOLTAGE FOR LCD | $V_{DD}-V_L$ | 0 | 13.5 | V |
| INPUT VOLTAGE | V_{IN} | V_{SS} | V_{DD} | V |
| OPERATING TEMPERATURE | T_{OP} | 0 | 50 | °C |
| STORAGE TEMPERATURE | T_{STG} | -20 | 70 | °C |

Electrical Characteristics (VDD=5.0±0.25V 25°C)

| PARAMETER | SYM | CONDITION | MIN | TYP | MAX | UNIT |
|----------------------|--------------|----------------|-----|-----|-----|------|
| INPUT HIGH VOLTAGE | V_{IH} | - | 2.2 | - | - | V |
| INPUT LOW VOLTAGE | V_{IL} | - | - | - | .6 | V |
| OUTPUT HIGH VOLTAGE | V_{OH} | $I_{OH}=0.2mA$ | 2.4 | - | - | V |
| OUTPUT LOW VOLTAGE | V_{OL} | $I_{OL}=1.2mA$ | - | - | 0.4 | V |
| POWER SUPPLY CURRENT | I_{DD} | $V_{DD}=5.0V$ | - | 1.0 | 2.2 | mA |
| POWER SUPPLY FOR LCD | $V_{DD}-V_L$ | $T_A=25°C$ | 4.3 | - | 4.7 | V |
| DRIVE METHOD | 1/16 Duty | | | | | |

Pin Connections

| PIN NO. | SYMBOL | LEVEL | FUNCTION | |
|---------|----------|-------|--|--------------|
| 1 | V_{SS} | - | 0V | Power supply |
| 2 | V_{DD} | - | 5V | |
| 3 | V_L | - | - | |
| 4 | RS | H/L | H: Data input L: Instruction data input | |
| 5 | R/W | H/L | H: Data read L: Data write | |
| 6 | E | H,H→L | Enable signal | |
| 7 | D0 | H/L | Data bus | |
| 8 | D1 | H/L | | |
| 9 | D2 | H/L | | |
| 10 | D3 | H/L | | |
| 11 | D4 | H/L | | |
| 12 | D5 | H/L | | |
| 13 | D6 | H/L | | |
| 14 | D7 | H/L | | |