

# HDM16116H-H

## Dimensional Drawing

16 Character x 1 Line, 2 Row connector

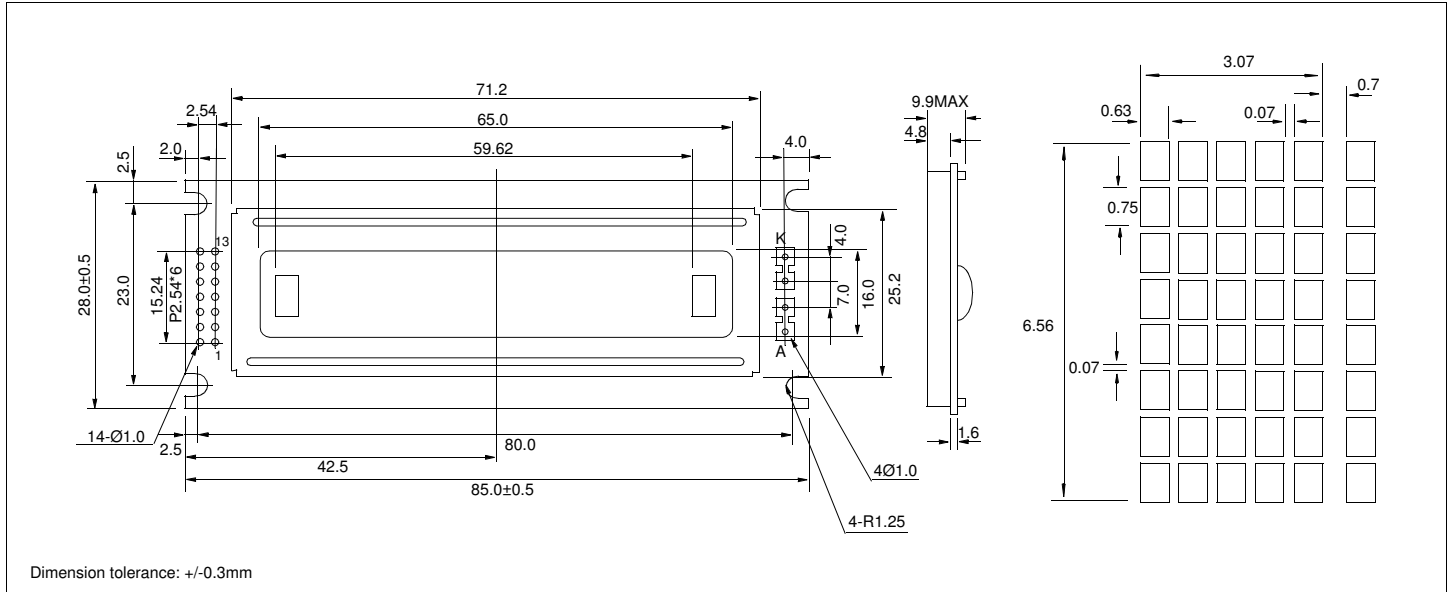

### Features

Character Format .....5x7 Dots with Cursor  
 Backlight.....EL Optional  
 Options..TN/Gray STN/Yellow STN, 12 o'Clock/6 o'Clock View  
 Normal/Extended Temperature  
 Normal/Negative Displays

### Physical Data

Module Size.....85.0W x 28.0H x 9.9T mm  
 Viewing Area Size.....65.0W x 16.0H mm  
 Weight.....25g

### Block Diagram

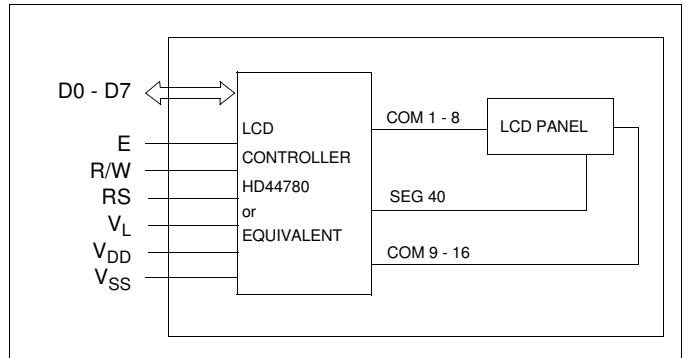

### Absolute Maximum Ratings

PARAMETER	SYMBOL	MIN	MAX	UNIT
SUPPLY VOLTAGE	$V_{DD}-V_{SS}$	0	7.0	V
SUPPLY VOLTAGE FOR LCD	$V_{DD}-V_L$	0	13.5	V
INPUT VOLTAGE	$V_{IN}$	$V_{SS}$	$V_{DD}$	V
OPERATING TEMPERATURE	$T_{OP}$	0	50	°C
STORAGE TEMPERATURE	$T_{STG}$	-20	70	°C

### Electrical Characteristics (VDD=5.0±0.25V 25°C)

PARAMETER	SYM	CONDITION	MIN	TYP	MAX	UNIT
INPUT HIGH VOLTAGE	$V_{IH}$	-	2.2	-	-	V
INPUT LOW VOLTAGE	$V_{IL}$	-	-	-	.6	V
OUTPUT HIGH VOLTAGE	$V_{OH}$	$I_{OH}=0.2mA$	2.4	-	-	V
OUTPUT LOW VOLTAGE	$V_{OL}$	$I_{OL}=1.2mA$	-	-	0.4	V
POWER SUPPLY CURRENT	$I_{DD}$	$V_{DD}=5.0V$	-	1.0	2.2	mA
POWER SUPPLY FOR LCD	$V_{DD}-V_L$	$T_A=25°C$	4.3	-	4.7	V
DRIVE METHOD	1/16 Duty					

### Pin Connections

PIN NO.	SYMBOL	LEVEL	FUNCTION	
1	$V_{SS}$	-	0V	Power supply
2	$V_{DD}$	-	5V	
3	$V_L$	-	-	
4	RS	H/L	H: Data input L: Instruction data input	
5	R/W	H/L	H: Data read L: Data write	
6	E	H,H→L	Enable signal	
7	D0	H/L	Data bus	
8	D1	H/L		
9	D2	H/L		
10	D3	H/L		
11	D4	H/L		
12	D5	H/L		
13	D6	H/L		
14	D7	H/L		