

HDM08216L-3

Dimensional Drawing

8 Character x 2 Lines LED Backlight

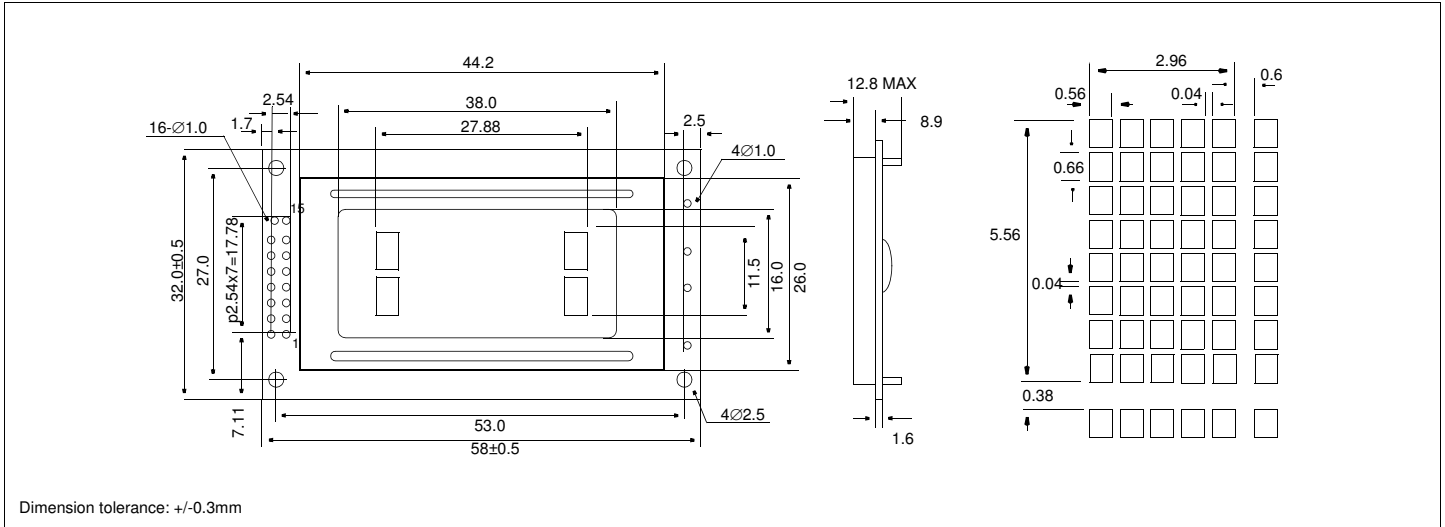

Features

Character Format 5x7 Dots with Cursor Backlight.....LED Options.TN/Gray STN/Yellow STN, 12 o'Clock/6 o'Clock View Normal/Extended Temperature Normal/Negative Displays

Physical Data

Module Size.....58.0W x 32.0H x 12.8T mm
Viewing Area Size.....38.0W x 16H mm
Weight.....18g

Absolute Maximum Ratings

PARAMETER	SYMBOL	MIN	MAX	UNIT
SUPPLY VOLTAGE	$V_{DD}-V_{SS}$	0	7.0	V
SUPPLY VOLTAGE FOR LCD	$V_{DD}-V_L$	0	13.5	V
INPUT VOLTAGE	V_{IN}	V_{SS}	V_{DD}	V
OPERATING TEMPERATURE	T_{OP}	0	50	°C
STORAGE TEMPERATURE	T_{STG}	-20	70	°C
LED FORWARD CURRENT	I_F	-	120	mA
LED REVERSE VOLTAGE	V_R	-	8	V
LED POWER CONSUMPTION	P_D	-	600	mW

Electrical Characteristics (VDD=5.0±0.25V 25 °C)

PARAMETER	SYM	CONDITION	MIN	TYP	MAX	UNIT
INPUT HIGH VOLTAGE	V_{IH}	-	2.2	-	-	V
INPUT LOW VOLTAGE	V_{IL}	-	-	-	0.6	V
OUTPUT HIGH VOLTAGE	V_{OH}	$I_{OH}=0.2mA$	2.4	-	-	V
OUTPUT LOW VOLTAGE	V_{OL}	$I_{OL}=1.2mA$	-	-	0.4	V
POWER SUPPLY CURRENT	I_{DD}	$V_{DD}=5.0V$	-	0.8	2.0	mA
POWER SUPPLY FOR LCD	$V_{DD}-V_L$	$T_A=25°C$	4.0	5.0	5.5	V
LED FORWARD VOLTAGE	V_F	$I_F=60mA$	3.8	4.0	4.2	V
BRIGHTNESS	L	$I_F=60mA$	82	103	-	NIT
DRIVE METHOD	1/16 Duty					

Block Diagram

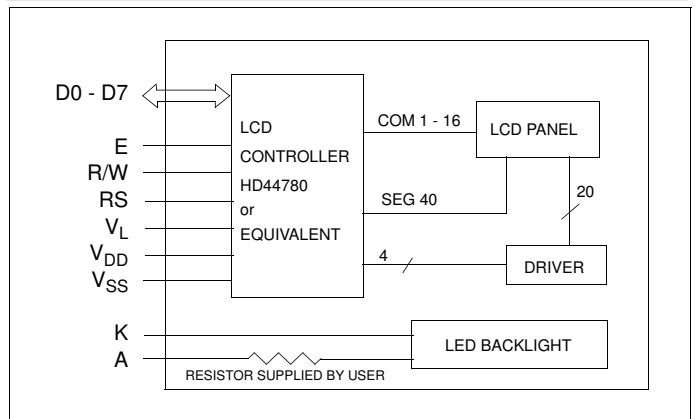

Pin Connections

PIN NO.	SYMBOL	LEVEL	FUNCTION	
1	V_{SS}	-	0V	Power supply
2	V_{DD}	-	5V	
3	V_L	-	-	
4	RS	H/L	H: Data input L: Instruction data input	
5	R/W	H/L	H: Data read L: Data write	
6	E	H,H→L	Enable signal	
7	D0	H/L	Data bus	
8	D1	H/L		
9	D2	H/L		
10	D3	H/L		
11	D4	H/L		
12	D5	H/L		
13	D6	H/L		
14	D7	H/L		
15	A	-	Anode for LED Backlight	
16	K	-	Cathode for LED Backlight	