

HDM 3224-CL

Dimensional Drawing

320 X 240 Dots Color Graphics, CCFL Backlight

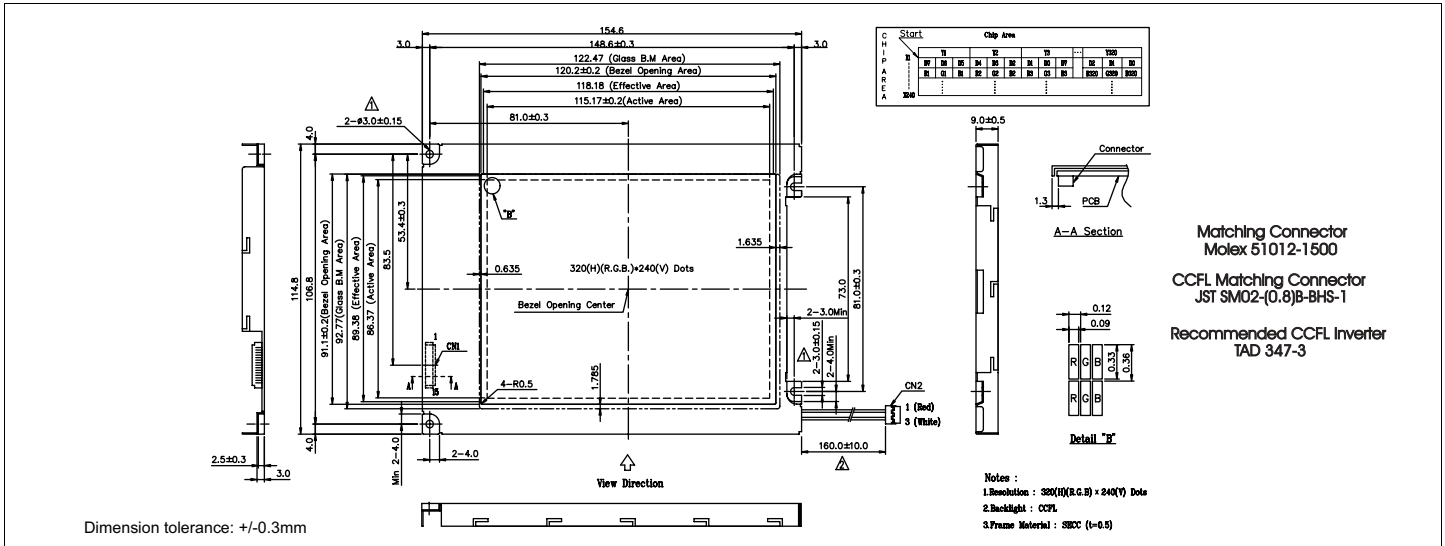

Features

- Backlight.....CCFL
- Options.....Color RGB
- Top/ Bottom Viewing
- Built-in Controller.....None
- Built-in DC-DC Inverte.....None

Physical Data

- Module Size.....154.6W x 114.8H x 9.0T mm
- Viewing Area Size.....120.2W x 91.1H mm
- Dot Pitch.....0.12W x 0.36H mm
- Dot Size.....0.09W x 0.33H mm
- Weight.....195g

Absolute Maximum Ratings

PARAMETER	SYMBOL	MIN	MAX	UNIT
SUPPLY VOLTAGE	$V_{DD}-V_{SS}$	-0.3	6.5	V
SUPPLY VOLTAGE FOR LCD	V_{EE}	0	30	V
INPUT VOLTAGE	V_{IN}	-0.3	$V_{DD}+0.3$	V
OPERATING TEMPERATURE	T_{OP}	-20	70	°C
STORAGE TEMPERATURE	T_{STG}	-30	80	°C

Electrical Characteristics (VDD=3-5.0±5% 25°C)

PARAMETER	SYM	CONDITION	MIN	TYP	MAX	UNIT
INPUT HIGH VOLTAGE	V_{IH}	- V	.8V _{DD}	-	V _{DD}	V
INPUT LOW VOLTAGE	V_{IL}	-	0	-	.2V _{DD}	V
SUPPLY VOLTAGE	V_{DD}	-	4.5	5.0	5.5	V
	V_{EE}	-	2.7	3.0	3.3	V
SUPPLY CURRENT	I_{DD}	$V_{DD} = 3/5V$	-	0.8	1.2	mA
	I_{EE}	$V_{EE} = 25.6$	-	4.8	7.2	mA
CCFL OP VOLTAGE	V_{FL}			474		V _{rms}
CCFL OP CURRENT	I_{FL}		2	5	6	mA _{rms}
CCFL START VTG.	V_{SL}	$T_a=25^{\circ}C$			750	V _{rms}
CCFL FREQUENCY	F_{FL}		35	50	65	KHz
BRIGHTNESS	L			180		NIT
DRIVE METHOD			1/240 DUTY			

Power Supply

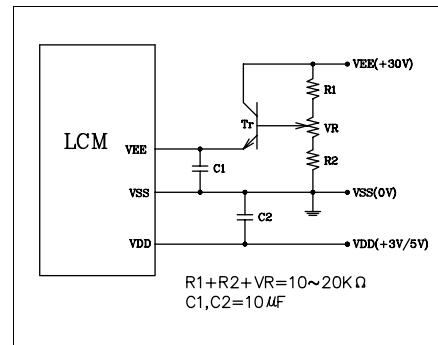

Pin Connections

PIN NO.	SYMBOL	LEVEL	FUNCTION
DATA CONNECTOR			
1	FRAME	H	First Line Marker
2	LOAD	H/L	Data Latch
3	CP	H/L	Data shift
4	DISPOFF	H/L	H = On, L = Off
5	V_{DD}	5V	Power supply for logic
6	V_{SS}	0V	Ground
7	V_{EE}	-	Contrast Adjust Voltage
8	D7	H/L	Data bus
9	D6	H/L	
10	D5	H/L	
11	D4	H/L	
12	D3	H/L	
13	D2	H/L	
14	D1	H/L	
15	D0	H/L	
CCFL CONNECTOR			
1	V_{CFL}	-	Power supply for CCFL
2	NC	-	No Connection
3	V_{CFL}	-	CCFL Ground