

FIBER-OPTIC INPUT FLOW SIGNAL CONDITIONER

for Use with the LIGHTSPEED™ Paddlewheel Flow Sensor

PATENTED
Covered by U.S. and
International patents and
pending applications



FLSC90-A
Signal Conditioner
Shown smaller than
actual size

NEMA 4 Enclosure

- ✓ 0.15% Accuracy
- ✓ 4 to 20 mA or 1 to 5 Vdc Output
- ✓ Compact Industrial Design
- ✓ CE Marked
- ✓ NEMA 4 Enclosure

FLSC90-A
\$390
Basic Unit



FP9001A, \$225,
fiber optic flow
sensor sold
separately, please
see page F-19.

NEWPORT's Model FLSC90-A fiber-optic signal conditioner has been designed to interface directly with FP-9000A series LIGHTSPEED™ paddlewheel flow sensors. The FLSC90-A provides a high intensity light source to the patented paddlewheel sensor through a semi-flexible duplex fiber-optic cable. Returning light pulses are measured and converted by the signal conditioner's electronics to a scalable analog output that is proportional to the flowrate. The ability of the paddlewheel flow sensor to operate in harsh and heavy electrical noise environments via the fiber optic cable link makes this system ideal for such applications. The industry standard 4 to 20 mA or 1 to 5 Vdc analog output can connect directly to many of process meters, controllers, dataloggers or data acquisition systems.

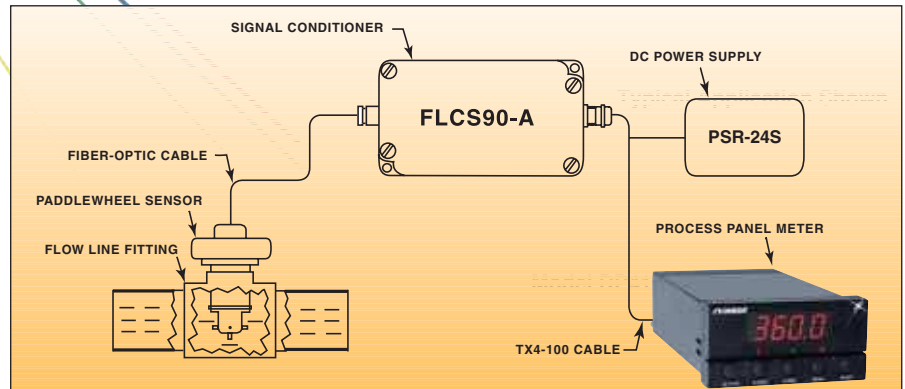

Paddlewheel is covered by U.S. and international patents and pending applications.

SPECIFICATIONS

- Accuracy:** $\pm 0.15\%$ of full scale
- Repeatability:** ± 0.025
- Input:** Light pulses from fiber optic flow sensor (FP-9000 Series) See Note*
- Min. Input Frequency:** 65 Hz
- Max. Input Frequency:** 960 Hz
- Ambient Operating Range:** 0 to 49°C (32 to 120°F)
- Power:** 8-32 Vdc @ 40 mA
- Outputs (3-Wire Configuration):** 4-20 mA/1-5 Vdc (Field Selectable)
- Maximum Loop Resistance:** (Vsupply-8V)/.020 A = Ohms
- Dimensions:** 114.5 L x 63.5 W x 35 mm H (4.51 x 2.50 x 1.38")
- Storage Temperature:** -20 to 65°C (-4 to 149°F)
- Enclosure/Class:** Die cast aluminium, NEMA 4 (IP66)
- CE Approved:** Yes
- Weight:** 238 g (8.3 oz)

AVAILABLE FOR FAST DELIVERY!

To Order (Specify Model Number)

Model No.	Price	Description
FLSC90-A	\$390	Fiber optic signal conditioner

Ordering Example: FLSC90-A, fiber-optic signal conditioner, plus TX4-100, 4-conductor power/output cable, plus PSR-245, 24 Vdc power supply plus OCW-3,

Accessories

Model No.	Price	Description
TX4-100	\$28.50	4-conductor power/output cable 30 m (100')
PSR-24S	60.00	24 Vdc regulated power supply
FLSC90-CA9*	35.00	Fiber-optic extension cable 2.7 m (9')
PE-1011	109.95	Reference Book: Instrumentation for Engineering Measurements

* Note: Only one extension cable can be used to extend the paddlewheel a maximum of 5.4 m (18') from the FLSC90-A signal conditioner.