

Series 260F and 385F

Flanged Thermowells for ¼" and ⅜" Diameter Elements



Application:

260F series fits standard length ¼" diameter elements.
385F series fits standard length ⅜" diameter elements.

Flange Sizes:

1 and 1½" flanges in all facings and pressure ratings are standard. Other sizes are available on application.

Materials:

Flanges and wells made of Carbon Steel (C-1018), A.I.S.I. 304, A.I.S.I. 316, and Monel® are available for quick delivery. Other materials are available.

Protective Coatings for Thermowells:

- Resist corrosion
 - For chemical baths
 - Color-coded sensors for process control
 - Available in PFA, Epoxy and other materials.
- Consult Sales Department for complete information

Welding:

Primary weld is "J" groove type; secondary weld is 45° bevel groove. Welding is performed by certified welders using inert gas shielded arc.

Cap and Chain Options: add suffix "-CC" to the end of the model number, for an additional cost.

Series 260F and 385F

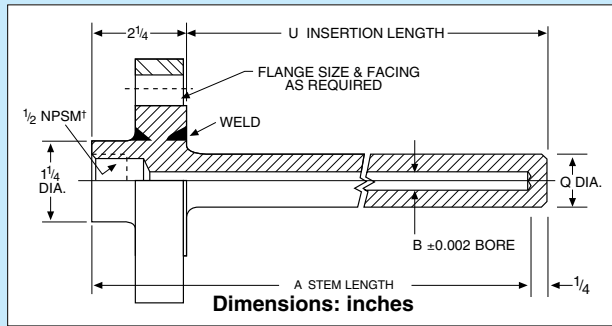

† NPSM internal pipe thread will accept both NPT and NPS male threads.

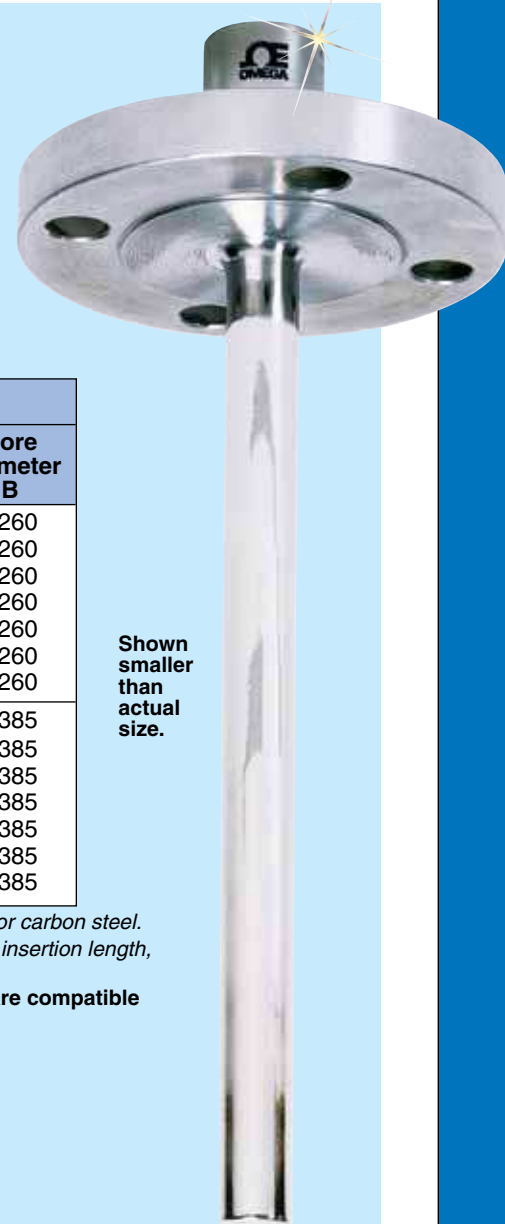

Shown smaller than actual size.

To Order Visit newportUS.com/260_385F for Pricing and Details

| Model Number | Stem Length A | Insertion Length U | Shank Diameter Q | Bore Diameter B |
|--------------|---------------|--------------------|------------------|-----------------|
| 260F-U2-(*) | 4 | 2 | ¼" | 0.260 |
| 260F-U4-(*) | 6 | 4 | ¼" | 0.260 |
| 260F-U7-(*) | 9 | 7 | ¼" | 0.260 |
| 260F-U10-(*) | 12 | 10 | ¼" | 0.260 |
| 260F-U13-(*) | 15 | 13 | ¼" | 0.260 |
| 260F-U16-(*) | 18 | 16 | ¼" | 0.260 |
| 260F-U22-(*) | 24 | 22 | ¼" | 0.260 |
| 385F-U2-(*) | 4 | 2 | ⅜" | 0.385 |
| 385F-U4-(*) | 6 | 4 | ⅜" | 0.385 |
| 385F-U7-(*) | 9 | 7 | ⅜" | 0.385 |
| 385F-U10-(*) | 12 | 10 | ⅜" | 0.385 |
| 385F-U13-(*) | 15 | 13 | ⅜" | 0.385 |
| 385F-U16-(*) | 18 | 16 | ⅜" | 0.385 |
| 385F-U22-(*) | 24 | 22 | ⅜" | 0.385 |

* Specify material type "304SS" for 304 stainless steel, "316SS" for 316 stainless steel, or "CS" for carbon steel.

Ordering Example: 260F-U4-316SS-11/2-300RF-316SS, 316 SS thermowell with a 0.260" ID, 4" insertion length, 6" stem length, with a 1½", 300 psi rated 316 SS raised face flange.

For Assistance in Choosing Head and Well Assemblies, See newportUS.com. These wells are compatible with NB1, NB2; PR-12, PR-14, and NPT-style probes, as well as DialTemp™ Thermometers.

Standard Flanges

| Rating lb/in2 | Size (inch) | Model Number (Flange Suffix) |
|---------------|-------------|------------------------------|
| 150 | 1 | 1-150RF (or FF)-(*) |
| | 1½ | 1½-150RF (or FF)-(*) |
| | 2 | 2-150RF (or FF)-(*) |
| 300 | 1 | 1-300RF (or FF)-(*) |
| | 1½ | 1½-300RF (or FF)-(*) |
| | 2 | 2-300RF (or FF)-(*) |

Wells and flanges are made of the same material.

See newportUS.com for Maximum Fluid Velocity.

* Specify material type "304SS" for 304 stainless steel, "316SS" for 316 stainless steel, or "CS" for carbon steel.

To Order: Add completed model number as a suffix to the thermowells featured in the chart above. It is recommended to consult factory when ordering flanged thermowells.

Consult factory for recommendations as to pressure and temperature ratings for flanged thermowells.