

iSeries 1/8 DIN Temperature, Process and Strain PID Controllers

i8 Series



shown smaller than actual size.



- ✓ High Quality
- ✓ 5-Year Warranty
- ✓ High Accuracy: $\pm 0.5^{\circ}\text{C}$ ($\pm 0.9^{\circ}\text{F}$), 0.03% Reading
- ✓ User-Friendly, Simple to Configure
- ✓ Free Software
- ✓ Full Autotune PID Control
- ✓ Universal Inputs: RTD, Thermocouple, Process Voltage/Current, Strain
- ✓ Totally Programmable Color Displays Standard
- ✓ Built-In Excitation Standard
- ✓ 2 Control or Alarm Outputs: DC Pulse, Mechanical Relays, Analog Voltage and Current
- ✓ Embedded Internet Connectivity Available

The NEWPORT® i8 is a 1/8 DIN size [96 x 48 mm (3.7 x 1.9")] digital panel meter featuring the big iSeries color-changing display. The digits are twice the size of typical 1/8 DIN panel meters. The iSeries meters feature the only LED displays that can be programmed to change color between GREEN, AMBER, and RED at any setpoint or alarm point. The "i8" model is available as an extremely accurate programmable digital panel meter with no outputs or with dual outputs for controlling or alarming functions. Other options include isolated programmable analog output, serial communications, Modbus and Ethernet. The user can easily program the i8 for any control or alarming requirement from simple on/off to full autotune PID with a choice of form C SPDT relays, solid state relays, DC pulse, and analog (voltage and current) outputs.

Fully isolated analog output for retransmission of the process value is available in addition to the control and alarm relays (specify model i8A33).

The i8 covers a broad selection of transducer and transmitter inputs with 2 input models.

The universal temperature and process instrument (i models) handles 10 common types of thermocouples, multiple RTDs, and several process (DC) voltage and current ranges. This model also features built-in excitation, 24 Vdc @ 25 mA. With its wide choice of signal inputs, this model is an excellent choice for measuring or controlling temperature with a thermocouple, RTD, or 4 to 20 mA transmitter.

The strain and process instruments (iS models) measure inputs from load cells, pressure transducers, and most any strain gage sensor as well as process voltage and

current ranges. The iS has built-in 5 or 10 Vdc excitation for bridge transducers, 5 Vdc @ 40 mA or 10 Vdc @ 60 mA (any excitation voltage between 5 and 24 Vdc is available by special order). This iS model supports 4- and 6-wire bridge configurations, ratiometric and non-ratiometric measurements.

The iS features fast and easy "in process" calibration/scaling of the signal inputs to any engineering units. This model also features 10-point linearization which allows the user to linearize the signal input from extremely nonlinear transducers of all kinds.

Input Type	Range	Accuracy	
Universal Process			
Process Voltage	0 to 100 mV, 0 to 1 V, 0 to 10 Vdc	0.03% rdg	
Process Current	0 to 20 mA (4 to 20 mA)	0.03% rdg	
Excitation	24 V @ 25 mA	—	
Universal Strain/Process			
Process Voltage	0 to 100 mV, -100 to 1 V, 0 to 10 Vdc	0.03% rdg	
Process Current	0 to 20 mA (4 to 20 mA)	0.03% rdg	
Excitation	5 V @ 40 mA, 10 V @ 60 mA	—	
Nickel RTD Input (FS Required)			
RTD-1N (Nickel MIL-T-7990B)	0 to 200°C (32 to 392°F)	0.1°C (0.2°F)	
RTD-2N (Nickel MIL-T-7990B)	-40 to 300°C (-40 to 572°F)	0.3°C (0.5°F)	
Temperature			
J	Iron - Constantan	-210 to 760°C (-346 to 1400°F)	0.4°C (0.7°F)
K	CHROMEGA™- ALOMEGA™	-270 to -160°C/-160 to 1372°C (-454 to -256°F/-256 to 2502°F)	1.0°C/0.4°C (1.8°F/0.7°F)
T	Copper - Constantan	-270 to -190°C/-190 to 400°C (-454 to -310°F/-310 to 752°F)	1.0°C/0.4°C (1.8°F/0.7°F)
E	CHROMEGA™ - Constantan	-270 to -220°C/-220 to 1000°C (-454 to -364°F/-364 to 1832°F)	1.0°C/0.4°C (1.8°F/0.7°F)
R	Pt / 13%Rh-Pt	-50 to 40°C/40 to 1768°C (-58 to 104°F/104 to 3214°F)	1.0°C/0.5°C (1.8°F/0.9°F)
S	Pt / 10%Rh-Pt	-50 to 100°C/100 to 1768°C (-58 to 212°F/212 to 3214°F)	1.0°C/0.5°C (1.8°F/0.9°F)
B	30% Rh-Pt / 6%Rh-Pt	100 to 640°C/640 to 1820°C (212 to 1184°F/1184 to 3308°F)	1.0°C/0.5°C (1.8°F/0.9°F)
C	5% Re-W / 26%Re-W	0 to 2320°C (32 to 4208°F)	0.4°C (0.7°F)
N	Nicrosil - Nisil	-250 to -100°C/-100 to 1300°C (-418 to -148°F/-148 to 2372°F)	1.0°C/0.4°C (1.8°F/0.7°F)
L	J DIN	-200 to 900°C (-328 to 1652°F)	0.4°C (0.7°F)
RTD	Pt, 0.00385, 100, 500, 1000 Ω	-200 to 900°C (-328 to 1652°F)	0.4°C (0.7°F)
RTD	Pt, 0.00392, 100, 500, 1000 Ω	-200 to 850°C (-328 to 1652°F)	0.4°C (0.7°F)

iSeries change color

PATENTED

Totally Programmable Color Displays

The NEWPORT® i/8, i/16, and i/32 are the first complete series of 1/8, 1/16 and 1/32 DIN process control instruments with totally programmable color displays. The display can be programmed to change color at any setpoint or alarm point.



At Any
Setpoint

Dimensions: in (mm)

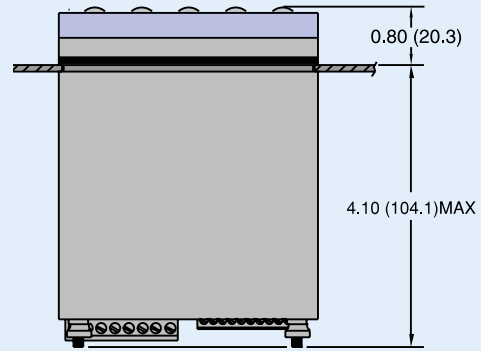

TOP VIEW

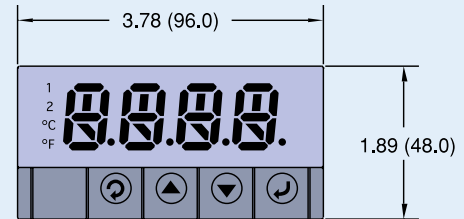

Options

Ordering Suffix	Description
-AL	Limit alarm version (alarms only, no PID control) ^{*4}
-SM	Simplified menu (on/off control or alarms, no PID) ^{*6}
Networks Options	
-EIT	Ethernet with embedded Web server
-C24	Isolated RS232 and RS485/422, 300 to 19.2 Kb ^{*2}
-C4EIT	Ethernet with embedded Web server + isolated RS485/422 hub for up to 31 devices ^{*1}
Power Supply	
-DC	12 to 36 Vdc, 24 Vac ^{*5}
Factory Setup	
,FS	Factory setup and configuration
,FS(RTD-1N)	Customized "iS" Model for MIL-T-7990B nickel RTD input, 0 to 200°C (32 to 392°F)
,FS(RTD-2N)	Customized "iS" Model for MIL-T-7990B nickel RTD input, -40 to 300°C (-40 to 572°F)
Software (Requires Network Option)	
OPC-SERVER LICENSE	OPC server/driver software license

^{*1} Ethernet options are not available for the i8A controller.

^{*2} "-DC", "-C24", and "-C4EIT" not available with excitation.

^{*3} Analog output is not available with "-AL" units.

^{*4} i8A0x-AL contains 1 alarm and 1 analog retransmission.

^{*5} 20 to 36 Vdc for i8A, i8-C4EIT, i8-EIT.

^{*6} "-SM" option not available on iS strain models.

To Order Visit newportUS.com/i8_embed for Pricing and Details

Model No.	Output 1	Output 2
2 Control Outputs		
i833	Relay	Relay
i844	DC pulse	DC pulse
i843	DC pulse	Relay
i842	DC pulse	0.5 A SSR
i822	0.5 A SSR	0.5 A SSR
i823	0.5 A SSR	Relay
i824	0.5 A SSR	DC pulse
i853	Analog	Relay
i854	Analog	DC pulse
i852	Analog	0.5 A SSR
2 Control Outputs and Isolated Analog Output		
i8A33	Relay	Relay
i8A44	DC pulse	DC pulse
i8A43	DC pulse	Relay
i8A42	DC pulse	0.5 A SSR
i8A22	0.5 A SSR	0.5 A SSR
i8A23	0.5 A SSR	Relay
i8A24	0.5 A SSR	DC pulse
Strain/Process Input with 2 Control Outputs		
iS833	Relay	Relay
iS834	Relay	DC pulse
iS844	DC pulse	DC pulse
iS843	DC pulse	Relay
iS842	DC pulse	0.5 A SSR
iS822	0.5 A SSR	0.5 A SSR
iS823	0.5 A SSR	Relay
iS824	0.5 A SSR	DC pulse
iS853	Analog	Relay
iS854	Analog	DC pulse
iS852	Analog	0.5 A SSR

Comes with complete operator's manual.

Ordering Examples: i8A22, 1/8 DIN temperature/process controller with isolated analog output and 2 SSR outputs.
iS833, 1/8 DIN strain/process controller with 2-relay outputs.

iSeries Common Specifications (All i/8, i/16, i/32 DIN)

Universal Temperature and Process Input ("i" Models)

Accuracy: $\pm 0.5^{\circ}\text{C}$ temp; 0.03% rdg

Resolution: $1^{\circ}/0.1^{\circ}$; 10 μV process

Temperature Stability:

RTD: $0.04^{\circ}\text{C}/^{\circ}\text{C}$

TC @ 25°C (77°F): $0.05^{\circ}\text{C}/^{\circ}\text{C}$

Cold Junction Compensation

Process: 50 ppm/ $^{\circ}\text{C}$

NMRR: 60 dB

CMRR: 120 dB

A/D Conversion: Dual slope

Reading Rate: 3 samples/s

Digital Filter: Programmable

Display: 4-digit 9-segment LED

10.2 mm (0.40"); i32, i16, i16D, i8DV

21 mm (0.83"); i8 10.2 mm (0.40") and

21 mm (0.83"); i8DH **RED, GREEN,**

and **AMBER** programmable colors

for process variable, setpoint and

temperature units

Input Types: Thermocouple, RTD,

analog voltage, analog current

Thermocouple Lead Resistance:

100 Ω max

Thermocouple Types (ITS 90):

J, K, T, E, R, S, B, C, N, L (J DIN)

RTD Input (ITS 68): 100/500/1000 Ω

Pt sensor, 2-, 3- or 4-wire; 0.00385 or

0.00392 curve

Voltage Input: 0 to 100 mV, 0 to 1V,

0 to 10 Vdc

Input Impedance: 10 M Ω for 100 mV

1 M Ω for 1 or 10 Vdc

Current Input: 0 to 20 mA (5 Ω load)

Configuration: Single-ended

Polarity: Unipolar

Step Response: 0.7 sec for 99.9%

Decimal Selection:

Temperature: None, 0.1

Process: None, 0.1, 0.01 or 0.001

Setpoint Adjustment:

-1999 to 9999 counts

Span Adjustment:

0.001 to 9999 counts

Offset Adjustment: -1999 to 9999

Excitation (Not Included with

Communication): 24 Vdc @ 25 mA

(not available for low-power option)

Universal Strain and Process Input ("iS" Models)

Accuracy: 0.03% reading

Resolution: 10/1 μV

Temperature Stability: 50 ppm/ $^{\circ}\text{C}$

NMRR: 60 dB

CMRR: 120 dB

A/D Conversion: Dual slope

Reading Rate: 3 samples/s

Digital Filter: Programmable

Input Types: Analog voltage and current

Voltage Input: 0 to 100 mVdc,

-100 mVdc to 1 Vdc, 0 to 10 Vdc

Input Impedance: 10 M Ω for 100 mV;
1 M Ω for 1V or 10 Vdc

Current Input: 0 to 20 mA (5 Ω load)

Linearization Points: Up to 10

Configuration: Single-ended

Polarity: Unipolar

Step Response: 0.7 sec for 99.9%

Decimal Selection: None, 0.1, 0.01
or 0.001

Setpoint Adjustment:

-1999 to 9999 counts

Span Adjustment: 0.001 to 9999 counts

Offset Adjustment: -1999 to 9999

Excitation (Optional In Place Of

Communication): 5 Vdc @ 40 mA;
10 Vdc @ 60 mA

Control

Action: Reverse (heat) or direct (cool)

Modes: Time and amplitude proportional

control; selectable manual or auto PID,

proportional, proportional with integral,

proportional with derivative and anti-reset

Windup, and on/off

Rate: 0 to 399.9 s

Reset: 0 to 3999 s

Cycle Time: 1 to 199 s; set to 0 for on/off

Gain: 0.5 to 100% of span; setpoints 1 or 2

Damping: 0000 to 0008

Soak: 00.00 to 99.59 (HH:MM), or OFF

Ramp to Setpoint:

00.00 to 99.59 (HH:MM), or OFF

Auto Tune: Operator initiated from

front panel

Control Output 1 and 2

Relay: 250 Vac or 30 Vdc @ 3 A (resistive

load); configurable for on/off, PID and ramp

and soak

Output 1: SPDT, can be configured as

alarm 1 output

Output 2: SPDT, can be configured as

alarm 2 output

SSR: 20 to 265 Vac @ 0.05 to 0.5 A

(resistive load); continuous

DC Pulse: Non-isolated; 10 Vdc @ 20 mA

Analog Output (Output 1 Only):

Non-isolated, proportional 0 to 10 Vdc or

0 to 20 mA; 500 Ω max

Output 3 Retransmission:

Isolated Analog Voltage and Current

Current: 10 V max @ 20 mA output

Voltage: 20 mA max for 0 to 10 V output

Network and Communications

Ethernet: Standards compliance

IEEE 802.3 10 Base-T

Supported Protocols:

TCP/IP, ARP, HTTPGET

RS232/RS422/RS485: Selectable from

menu; both ASCII and Modbus protocol

selectable from menu; programmable

300 to 19.2 Kb; complete programmable

setup capability; program to transmit

current display, alarm status, min/max,

actual measured input value and status

RS485: Addressable from 0 to 199

Connection: Screw terminals

Alarm 1 and 2 (Programmable)

Type: Same as output 1 and 2

Operation: High/low, above/below,

band, latch/unlatch, normally open/

normally closed and process/deviation;

front panel configurations

Analog Output (Programmable):

Non-isolated, retransmission 0 to 10 Vdc

or 0 to 20 mA, 500 Ω max (output 1 only);

accuracy is $\pm 1\%$ of FS when following

conditions are satisfied: input is not scaled

below 1% of input FS, analog output is not

scaled below 3% of output FS

General

Power: 90 to 240 Vac $\pm 10\%$, 50 to 400Hz*,

110 to 375 Vdc, equivalent voltage

Low Voltage Power Option: 24 Vac**,

12 to 36 Vdc for i/S; 20 to 36 Vdc for dual

display, ethernet, and isolated analog output

from qualified safety approved source

Isolation

Power to Input/Output: 2300 Vac

per 1 minute test

For Low Voltage Power Option:

1500 Vac per 1 minute test

Power to Relay/SSR Output:

2300 Vac per 1 minute test

Relay/SSR to Relay/SSR Output:

2300 Vac per 1 minute test

RS232/485 to Input/Output:

500 Vac per 1 minute test

Environmental Conditions:

All Models: 0 to 55°C (32 to 131°F)

90% RH non-condensing

Dual Display Models:

0 to 50°C (32 to 122°F), 90% RH

non-condensing (for UL only)

Protection:

i/S32, 16, 16D, 8C:

NEMA 4X/Type 4 (IP65) front bezel

i/S8, 8DH, 8DV:

NEMA 1/Type 1 front bezel

Approvals: UL, C-UL, CE per

EN61010-1:2001, FM (temperature

units only)

Dimensions

i/8 Series: 48 H x 96 W x 127 mm D

(1.89 x 3.78 x 5")

i/16 Series: 48 H x 48 W x 127 mm D

(1.89 x 1.89 x 5")

i/32 Series: 25.4 H x 48 W x 127 mm D

(1.0 x 1.89 x 5")

Panel Cutout

i/8 Series: 45 H x 92 mm W

(1.772 x 3.622"), $\frac{1}{8}$ DIN

i/16 Series: 45 mm (1.772") square,

$\frac{1}{16}$ DIN

i/32 Series: 22.5 H x 45 mm W

(0.886 x 1.772"), $\frac{1}{32}$ DIN

Weight

i/8 Series: 295 g (0.65 lb)

i/16 Series: 159 g (0.35 lb)

i/32 Series: 127 g (0.28 lb)

* No CE compliance above 60 Hz.

** Units can be powered safely with 24 Vac power, but no certification for CE/UL are claimed.