

Current sense Transformer - CT01 100 261x



- Materials meet UL94V-0 rating
- Global accuracy $\pm 10\%$
- Applied standards:
ESCC-3201 generic (including MIL-STD-202)/ECSS-Q-ST-70-02C
and ESCC 3201 generic specification for space products
- Frequency range 10 kHz to 250 kHz
- Operating temperature range: -55°C to $+125^{\circ}\text{C}$
- Suited for IR and vapor reflow soldering
- Weight: $< 2\text{grams}$

Electrical Data (25°C)

ID Code	DCR _{1-3/2-4} mΩ $\pm 15\%$	DCR _{5-7/6-8} Ω $\pm 15\%$	L _{1-3/2-4} μH $\pm 40\%$	L _{1-3/2-4} mH $\pm 40\%$	Insulation 500VDC
CT01 100 261 x	2.5	1	3.9	9.9	$> 1\text{G}\Omega$

Turn ratio	Schematic	I _p	I _s (V _s =1V)	Z load
1/100		3,5 A	35 mA	33 Ω
1/50		3,5 A	70 mA	15 Ω

Notes

Typical performances at $+25^{\circ}\text{C}$
Storage Temperature -55°C to $+170^{\circ}\text{C}$ - 10mn Max

Application

Current detection/measurement for PWM control
(Isense) in High-Rel. SMPS

To Order

CT01 100	261	x
Range	Range	x = J J leaded x = W W Terminals

CT01 100 261 x

Connections

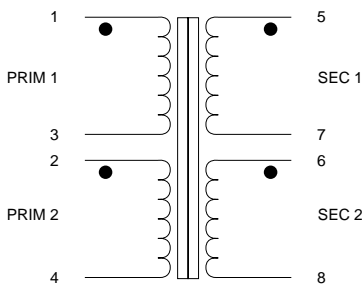

Marking

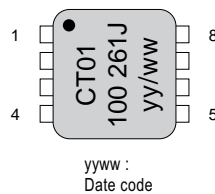

Dimensions (mm)

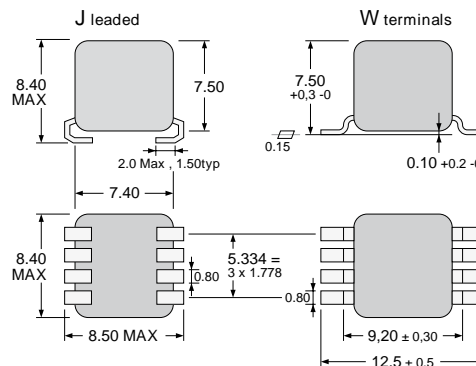

Packaging

Tape and Reel:

J leaded - 600 units per reel of diameter 330 mm
W terminals - 400 units per reel of diameter 330 mm

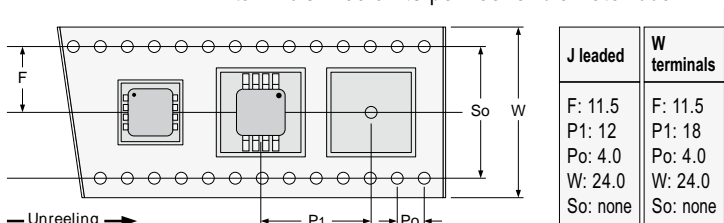

PCB Layout (mm)

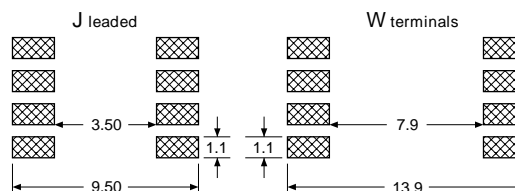

High Grade Technologies...
Power Magnetics...
Current Transformers...



Current Transformer for DC/DC Applications CT08 200 221 PR



- Designed for DC/DC Converter Applications
- Measurement up to $5.4 A_{RMS}$ ($8 A_{PEAK}$ - $3.6 A_{DC MAX}$) from 100 to 200 kHz with 2% Accuracy
- Applied standards:
MIL-STD-202, ECSS-Q-70-02
ESCC-3201, DO-160

Electrical Data (25°C)

ID Code	Accuracy (-40°C / +110°C)	Transformer ratio	Secondary Inductance	Secondary DC Resistance	Insulation
CT08 200 221R	< 2% with $R_L = 113 \Omega$ theoretical < 2% with $R_L = 113 \Omega$ at 1% (E96)	$V_{OUT} / I_{IN} = 0.56$ ($N_p / N_s = 1 : 200$)	$L_{3-4} = 11.0 \text{ mH}$ ($\pm 25\%$) (100 kHz - $1 V_{RMS}$)	$R_{3-4} = 5.8 \Omega$ ($\pm 10\%$)	500 V_{DC} - 1 min (RI $\geq 100 \text{ M}\Omega$) between windings

Typical Dimensions (mm)

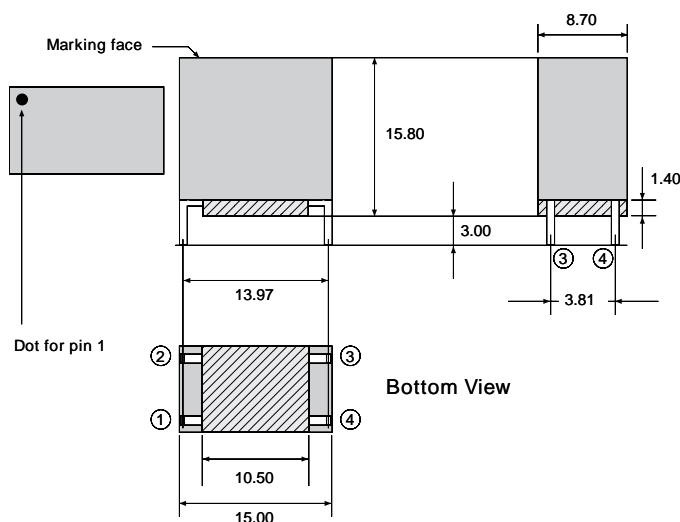

Notes

- The component is dedicated to measure RMS current up to $I_{IN} = 5.4 A_{RMS}$ ($8 A_{PEAK}$ and $3.6 A_{DC MAX}$) for a waveform of working frequency from 100 to 200 kHz. Image of this current is the voltage ($V_{OUT} = 3 V_{RMS MAX}$) picked on a resistive load $R_L = 113 \Omega$ at 1% (E96 series).
- The component can also make the measurement keeping the same accuracy but with a ratio $V_{OUT} / I_{IN} = 1.00$. In this case, image of the current is the voltage ($V_s = 5.4 V_{RMS MAX}$) picked on a resistive load $R_L = 200 \Omega$ at 1% (E96 series).
- Flammability compliance: UL94V0
- Insulation class (windings): H (180 °C)
- Operating temperature: -40 °C to +110 °C
- Storage temperature: -55 °C to +125 °C

Connections

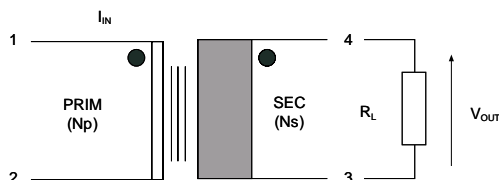

Marking



yyww :
Date code

Application Schem.

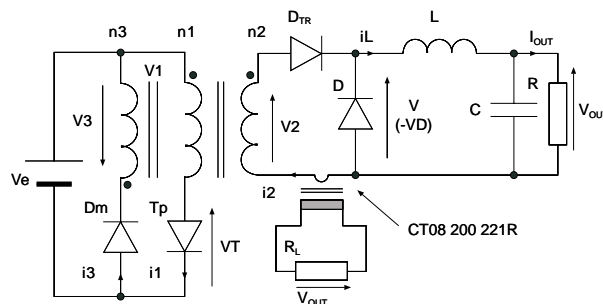

CT08 200 221R can be used for measurement of secondary current (i_2) of a DC/DC forward converter (3.3V/8A output and 100kHz working frequency example) for regulation and surveillance operations.

Current sense Transformer, up to 10Apk - CT91 xxx 231 WR

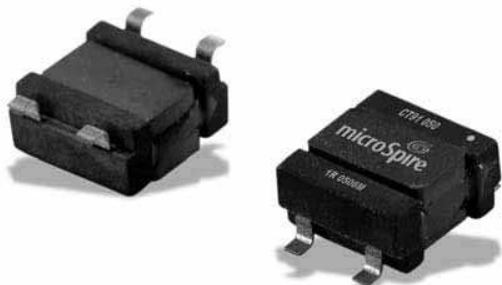

- Vout/Ipk ratio: 1V/8A
- Global accuracy $\pm 5\%$ on E96 series load resistor
- Low profile and light
- Materials meet UL94V-0 rating
- Applied standards:
ESCC-3201 generic (including MIL-STD-202)/ECSS-Q-70-02
- Frequency range 6kHz to 500kHz triangle wave
- Operating temperature range: -55°C to $+125^{\circ}\text{C}$
- Suited for IR and vapor reflow soldering
- Weight: 2grams

Electrical Data (25°C)

ID Code	Turn ratio	DCR ₁₋₂ mΩ	DCR ₃₋₄ Ω $\pm 15\%$	L ₃₋₄ mH $\pm 15\%$	Frequency range triangle wave	I _{pk} = I _{DC} + $\Delta I/2$ max	Z Load 1% ΔI	Insulation 500VDC
CT91 050 231 WR	1/50	<2	0.95	0.4	22kHz to 500kHz	10	6.81Ω	>1GΩ
CT91 075 231 WR	1/75	<2	2.15	0.9	15kHz to 300kHz	10	10.2Ω	>1GΩ
CT91 100 231 WR	1/100	<2	3.70	1.6	9kHz to 200kHz	10	13.7Ω	>1GΩ
CT91 200 231 WR	1/200	<2	14.6	6.4	6kHz to 70kHz	10	27.4Ω	>1GΩ

To Order

CT91 ### 231 WR			
CT91	###	231	WR
Range	Turn ratio	Range	Gull wing highrel

Notes

Typical performances at $+25^{\circ}\text{C}$
Storage Temperature -55°C to $+140^{\circ}\text{C}$

Dimensions (mm, top view)

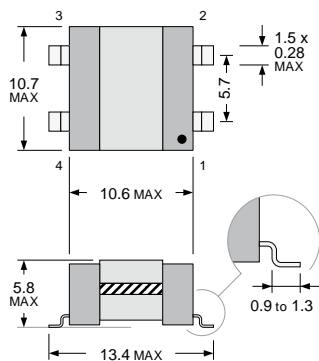

PCB Layout (suggested)

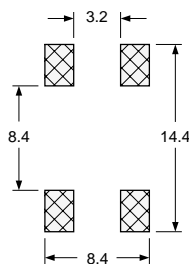

Application

Current detection/measurement for PWM control
(I_{sense}) in High-Rel. SMPS

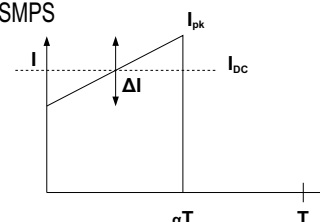

Connections

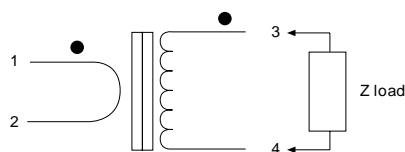

Packaging

Tape and Reel:
700 units per reel of diameter 330mm

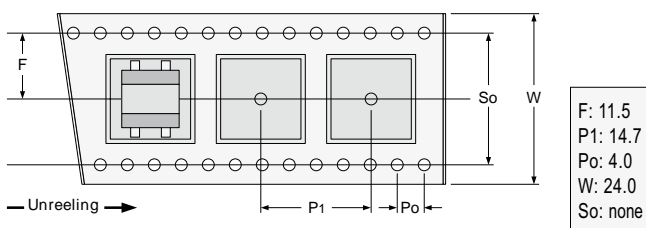

Marking

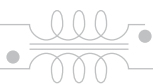
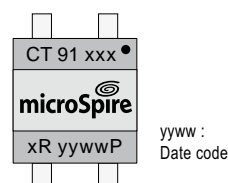

Current sense Transformer, 1/200/200 up to 17Apk - CT15 200 231 WR

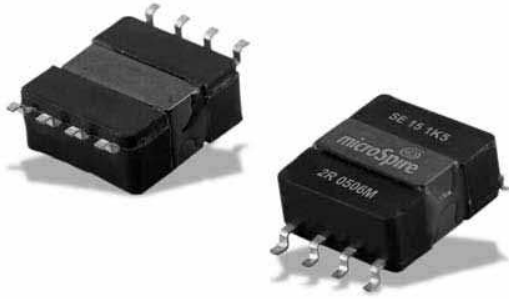

- Global accuracy $\pm 5\%$
- Low profile and light
- Materials meet UL94V-0 rating
- Applied standards:
ESCC-3201 generic (including MIL-STD-202)/ECSS-Q-70-02
- Frequency range 6 kHz to 100 kHz triangle wave
- Operating temperature range: -55°C to $+125^{\circ}\text{C}$
- Suited for IR and vapor reflow soldering
- Weight: 6 grams

Electrical Data (25°C)

ID Code	DCR ₁₋₂ mΩ	DCR _{5-6/7-8} Ω ±15%	L _{5-6/7-8} mH ±10%	Insulation 500VDC
CT15 200 231 WR	1.1	21.8	6.4	>1GΩ

Turn ratio	Schematic	I _p	I _s	Z load
1/400		17 A	42.5 mA	27 Ω
1/200		17 A	85 mA	15 Ω

Dimensions (mm, top view)

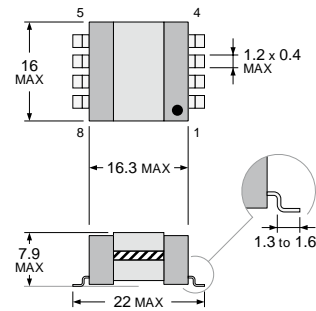

Notes

- Typical performances at $+25^{\circ}\text{C}$
- Storage Temperature: -55°C to $+170^{\circ}\text{C}$ / 7 mm
- Thermal index: 180°C

To Order

CT15		200	231	WR
Range	Turn ratio	Range	Gull wing highrel	

CT15 200 231 WR

Connections

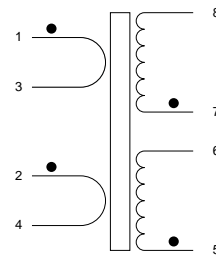

PCB Layout (suggested)

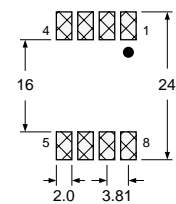

Packaging

Tape and Reel:
700 units per reel of diameter 330 mm

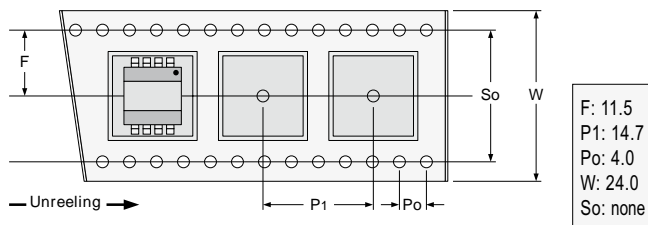

Marking

