

# METAL CASE HYPASS™ INTERFERENCE SUPPRESSION POLYESTER FILM CAPACITORS

TYPE 409P



## FEATURES

- High frequency filtering
- No series resonance
- Low inductance to ground

**MAJOR APPLICATIONS:** EMI suppression.

## PHYSICAL CHARACTERISTICS

**TORQUE:** Terminals shall withstand 10 inch pounds with no damage.

**DIMENSIONS:** See chart below, contact factory for additional sizes.

### MARKING:

Dearborn trademark, type or catalog number, capacitance, and voltage.

## ENVIRONMENTAL CHARACTERISTICS

### DC LIFE TEST:

- 150% of rated DC voltage for 250 hours at +85°C.
- No open or short circuits.
- No visible damage: Max. Cap chg: ±5%  
Min. I.R. = 50% of initial limit  
Max. D.F. = 2.0%

### THERMAL SHOCK AND IMMERSION CYCLING:

No visible damage: Max. Cap chg: ±5%  
Min. I.R. = 50% of initial limit  
Max. D.F. = 2.0%

## ELECTRICAL SPECIFICATIONS

**CAPACITANCE RANGE:** 0.10 µF to 0.5 µF

**DC VOLTAGE RATING:** 50 VDC to 1,000 VDC

**CAPACITANCE TOLERANCE:** +20% - 10%, ±10%

**OPERATING TEMPERATURE:** -40°C to +85°C

**DISSIPATION FACTOR:** 1.0% maximum

**VOLTAGE TEST:** 200% of rated voltage for 1 minute

### INSULATION RESISTANCE:

- At +25°C, 20,000 Megaohm-Microfarads, need not exceed 20,000 Megaohms
- At +85°C, 200 Megaohm-Microfarads, need not exceed 1,000 Megaohms

## TYPICAL SIZES

Current µF in Amps	Bracket mounting Dimensions						
	D	L	W	M	R	Y	Fig.
<b>50 WVDC</b>							
0.50 40	1.000	1.813	1.000	0.875	1.188	0.250	1
0.50 60	1.000	1.813	1.000	0.875	1.188	0.250	1
<b>200 WVDC</b>							
0.25 20	0.750	1.813	0.750	0.656	0.875	0.201	1
0.50 20	1.000	1.813	1.000	0.875	1.188	0.250	1
<b>400 WVDC</b>							
0.10 20	0.688	1.813	0.750	0.641	0.781	0.201	1
<b>600 WVDC</b>							
0.10 20	0.688	1.813	0.750	0.641	0.781	0.201	1
0.25 20	1.000	1.813	1.000	0.875	1.188	0.250	1
0.50 20	1.000	2.250	1.000	0.875	1.188	0.250	1

Current µF in Amps	Bulkhead mounting Dimensions						
	D	L	W	M	R	Y	Fig.
<b>200 WVDC</b>							
0.25 20	0.750	1.813	0.875	1.125	1.438	0.156	2
<b>400 WVDC</b>							
0.10 20	0.688	1.813	0.875	1.062	1.375	0.156	2
<b>600 WVDC</b>							
0.10 20	0.688	1.813	0.875	1.062	1.375	0.156	2
0.50 100	1.125	3.125	1.500	1.750	2.312	0.201	3
<b>1,000 WVDC</b>							
0.20 100	1.125	3.125	1.500	1.750	2.312	0.201	3

### Note:

Hypass capacitors rated at 200 WVDC or 400 WVDC may be used on 130 volt, 60Hz circuits. Capacitors rated at 600 and 1,000 WVDC may be used on 250 volt, 60Hz circuits.

## INSERTION LOSS OF A HYPASS™ CAPACITOR VS. A CONVENTIONAL CAPACITOR

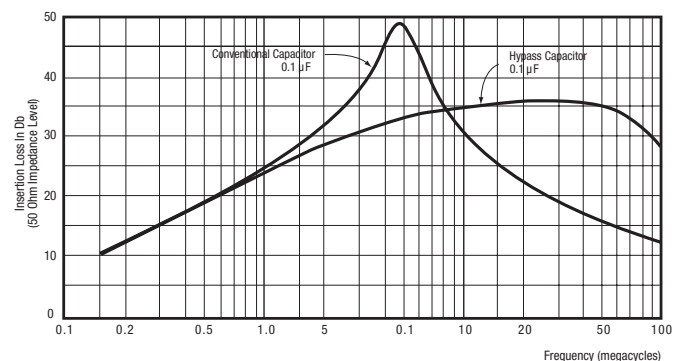

# METAL CASE HYPAS<sup>TM</sup> INTERFERENCE SUPPRESSION POLYESTER FILM CAPACITORS

FIGURE 1

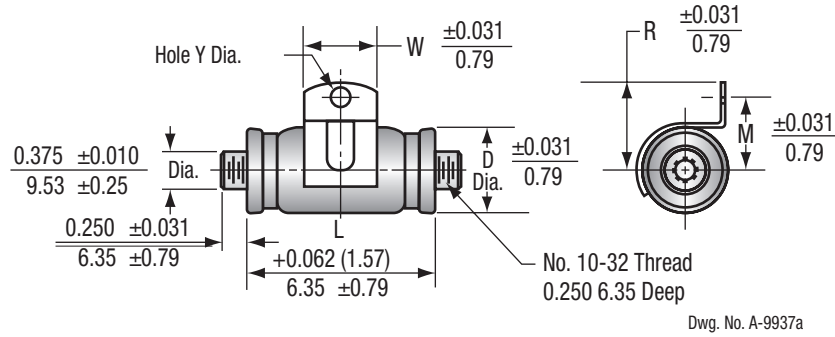

FIGURE 2

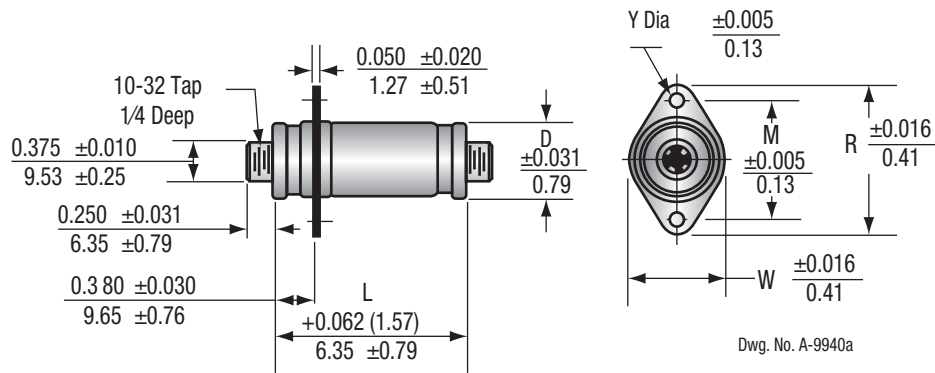
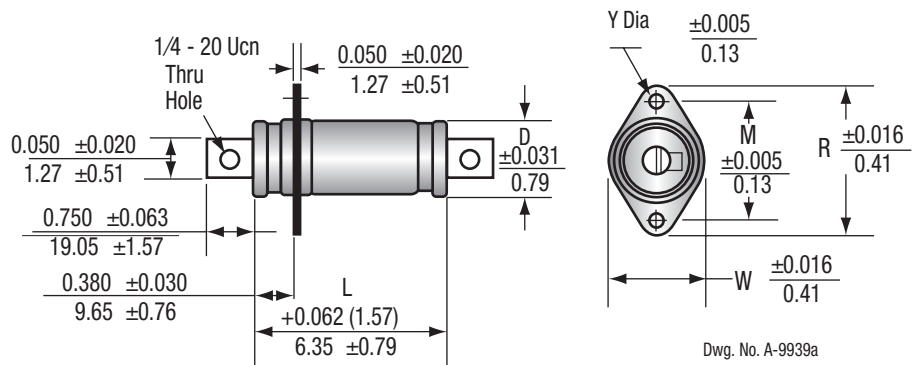

FIGURE 3



Dimensions:  $\frac{\text{Inches}}{\text{Millimeters}}$

Terminal Hardware Available On Special Order.