

Special Features

- MultiLINQ generates four NEC Class 2 rated constant voltage outputs from a single DC input
- Microprocessor controlled protection circuitry
- Low dissipation control (> 98% efficient)
- IP67 Rated
- Wide Input Voltage Operation
- Input Reverse Polarity Protection
- Blue POWER OK LED and Red FAULT LED
- Auxiliary Fault alarm
- Long Life, Low Cost
- Patent Pending

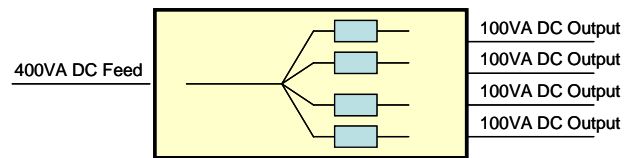
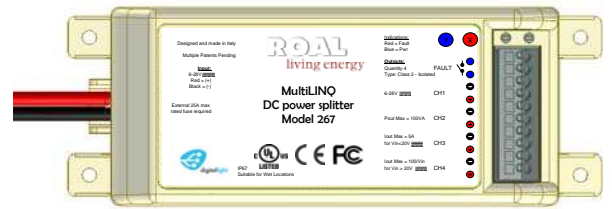

Applications and Benefits

MultiLINQ is designed for powering low voltage light fixtures that require a Class 2 limited power input. It is ideal for installations requiring multiple Class 2 power sources such as:

- Commercial Lighting
- Residential Lighting
- Signage

MultiLINQ generates multiple Class 2 constant voltage outputs, replacing low power AC-DC power supplies in the end product. The following diagram depicts a typical installation utilizing the MultiLINQ:

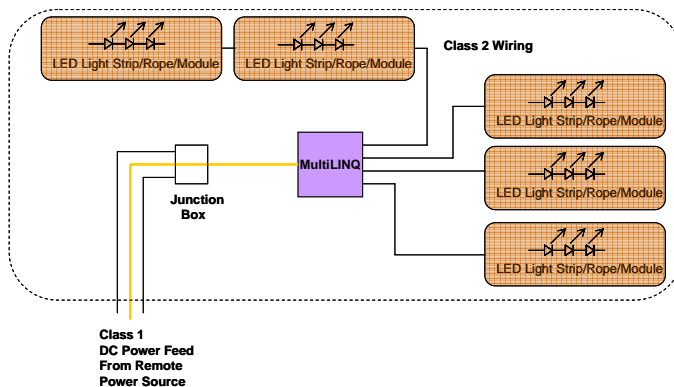

- Removes AC power from fixtures
- Reduces total quantity of AC-DC power supplies
- Reduces total material and installation cost
- Reduces maintenance costs
- Simplifies installations
- Simplifies certification process
- Smaller and lighter than the AC-DC power supplies it replaces
- Increases system reliability

Input and Output Specification

Input Voltage: 6VDC to 28VDC from a Class 1, SELV Source

Input Current: 20ADC Maximum

Isolation: 500VDC input and output to chassis

Output Voltage: Follows input voltage within 200mV

Output Rating: 100VA per channel at > 20VDC
Output current limited to 5A maximum per channel at < 20VDC



Mechanical

Enclosure:	Plastic, watertight assembly
Dimensions (LxWxH):	126.3mm x 55.5mm x 37.0mm (4.97" x 2.20" x 1.46")
Input Connection:	Flying leads, 12AWG, 300mm long
Output Connections:	Screwless Terminal Block
Outline Drawing:	

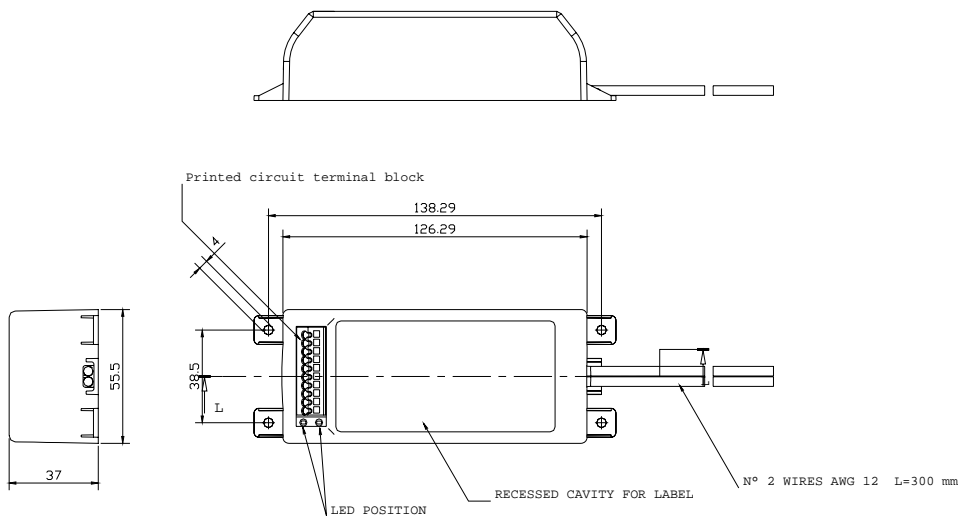

Environmental

Operating Temperature:	-30C to + 65C
Storage Temperature:	-40C to + 85C
Cooling:	Convection cooled
Ingress Protection:	IP67
Suitable for wet locations	

Safety Agency Approvals

UL60950 Listed in accordance with Low Power System (LPS) requirements. Equivalent to NEC Class 2.

Roal Electronics, S.p.A. may change product specifications and accordingly the information presented in this document. Customers are responsible for their products and applications using Roal Electronics, S.p.A. products. Roal Electronics, S.p.A. assumes no liability from the use of its products outside of specifications. No license is granted to any intellectual property rights by this document. ROAL ELECTRONICS, S.P.A. DISCLAIMS ALL REPRESENTATIONS AND WARRANTIES OF ANY KIND, EXPRESS OR IMPLIED, INCLUDING, BUT NOT LIMITED TO, IMPLIED WARRANTIES OF NON-INFRINGEMENT, MERCHANTABILITY AND FITNESS FOR A PARTICULAR PURPOSE.

Eu and RoW

ROAL Electronics S.p.A
Via Jesina 56/A
60022 – Castelfidardo (AN) - Italy
Tel:+39 071 721461
Fax:+ 39 071 72146 480

www.roallivingenergy.com

North America

ROAL Electronics USA, Inc.
701, Main St. Suite 405
Stroudsburg, PA18360
Phone: + 1 570 421 5750
Fax: +1 570 421 5687
DS1_MultilinQ_Rev02- Page. 2/2