

MODEL NO. : TM080SDHG02-20**ISSUED DATE: 2014-01-23****VERSION : Ver 1.0**

- Preliminary Specification
 Final Product Specification

Customer : _____

| Approved by | Notes |
|-------------|-------|
| | |

SHANGHAI AVIC Confirmed :

| Prepared by | Checked by | Approved by |
|-------------|------------|-------------|
| | | |

This technical specification is subjected to change without notice

Table of Contents

| | |
|---|----|
| Table of Contents..... | 2 |
| Record of Revision..... | 3 |
| 1 General Specifications | 4 |
| 2 Input/Output Terminals | 5 |
| 3 Absolute Maximum Ratings..... | 7 |
| 4 Electrical Characteristics | 8 |
| 5 Timing Chart..... | 11 |
| 6 Optical Characteristics | 14 |
| 7 Environmental / Reliability Test..... | 17 |
| 8 Mechanical Drawing..... | 18 |
| 9 Packing drawing..... | 19 |
| 10 Precautions for Use of LCD Modules | 20 |

CONFIDENTIAL

1 General Specifications

| | Feature | Spec |
|-----------------------------------|---------------------------------|--------------------------|
| Display Spec. | Size | 8 inch |
| | Resolution | 800(RGB) x 600 |
| | Interface | RGB 24 bits with TCON |
| | Color Depth | 16.7M |
| | Technology Type | a-Si |
| | Pixel Pitch (mm) | 0.2025(H) x 0.2025 (V) |
| | Pixel Configuration | R.G.B. Vertical Stripe |
| | Display Mode | TM with Normally White |
| | Surface Treatment(Up Polarizer) | Anti Glare |
| | Viewing Direction (Note 1) | 12 o'clock |
| | Gray Scale Inversion Direction | 6 o'clock |
| Mechanical Characteristics | Panel (W x H x D) (mm) | 171.60 x 132.30 x 1.85 |
| | LCM (W x H x D) (mm) | 183.0(W)×141.0(H)×5.6(D) |
| | Active Area(mm) | 162.0 (W) x121.5 (H) |
| | With /Without TSP | Without TSP |
| | Weight (g) (Note 3) | 250 |
| | LED Numbers | 30LEDs |

Note 1: Viewing direction for best image quality is different from TFT definition. There is a 180 degree shift.

Note 2: Requirements on Environmental Protection: RoHS

Note 3: LCM weight tolerance: +/- 5%

For all inquiries, please contact: [TIANMA Europe GmbH](mailto:Info@tianma.eu) , Herrenalber Str. 22, 76199 ,
 Karlsruhe,Germany,Tel: 49 (721) 89311-0, Email: Info@tianma.eu

2 Input/Output Terminals

2.1 CN1 of FPC

Matching Connector of FH12A-50S-0.5H

| Pin No. | Symbol | I/O | function | Remarks |
|---------|------------------|-----|-----------------------|--|
| 1 | NC | - | No connection | |
| 2 | NC | - | No connection | |
| 3 | NC | - | No connection | |
| 4 | NC | - | No connection | |
| 5 | GND | P | Power ground | |
| 6 | V _{COM} | I | Common voltage | |
| 7 | VCC | P | Power supply 3.3V | |
| 8 | MODE | I | DE/SYNC mode select | MODE=1,DE mode; MODE=0, HSD/VSD mode. |
| 9 | DE | I | Data input enable | |
| 10 | VS | I | Vertical syncinput | |
| 11 | HS | I | Horizontal sync Input | |
| 12 | B7 | I | Blue data(MSB) | |
| 13 | B6 | I | Blue data | |
| 14 | B5 | I | Blue data | |
| 15 | B4 | I | Blue data | |
| 16 | B3 | I | Blue data | |
| 17 | B2 | I | Blue data | |
| 18 | B1 | I | Blue data | |
| 19 | B0 | I | Blue data(LSB) | |
| 20 | G7 | I | Green data(MSB) | |
| 21 | G6 | I | Green data | |
| 22 | G5 | I | Green data | |
| 23 | G4 | I | Green data | |
| 24 | G3 | I | Green data | |
| 25 | G2 | I | Green data | |
| 26 | G1 | I | Green data | |
| 27 | G0 | I | Green data(LSB) | |
| 28 | R7 | I | RED data(MSB) | |
| 29 | R6 | I | RED data | |
| 30 | R5 | I | RED data | |
| 31 | R4 | I | RED data | |
| 32 | R3 | I | RED data | |

The information contained herein is the exclusive property of TIANMA MICRO-ELECTRONICS Corporation, and shall not be distributed, reproduced, or disclosed in whole or in part without prior written permission of TIANMA MICRO-ELECTRONICS Corporation.

For all inquiries, please contact: **TIANMA Europe GmbH** , Herrenalber Str. 22, 76199 ,
Karlsruhe,Germany,Tel: 49 (721) 89311-0, Email: Info@tianma.eu

| | | | | |
|----|------------------|---|---------------------------|--|
| 33 | R2 | I | RED data | |
| 34 | R1 | I | RED data | |
| 35 | R0 | I | RED data(LSB) | |
| 36 | GND | P | Power ground | |
| 37 | DCLK | I | Clock for input data | |
| 38 | GND | P | Power ground | |
| 39 | L/R | I | Left/right scan selection | L/R=1,from left to right; L/R=0, from right to left. |
| 40 | U/D | I | Up/down selection | U/D=0,from up to down; U/D=1,from down to up. |
| 41 | V _{GH} | P | Gate on voltage | |
| 42 | V _{GL} | P | Gate off voltage | |
| 43 | AV _{DD} | P | Power for analog circuit | |
| 44 | RESET | I | Global reset pin | |
| 45 | NC | - | No connection | |
| 46 | V _{COM} | I | Common voltage | |
| 47 | DITHB | I | Dithering function | DITHB=1,Disable internal dithering function; DITHB=0,Enable internal dithering function |
| 48 | GND | P | Power ground | |
| 49 | NC | - | No connection | |
| 50 | NC | - | No connection | |

Note: I/O definition.

I---Input pin, O---Output pin, P--- Power/Ground, N--- No Connection

2.2 CN2 of LED BLU Connector

Matching Connector of 35001-WR-02

| Pin | Symbol | I/O | Description | Remark |
|-----|--------|-----|-------------|-------------|
| 1 | LED+ | P | LED Anode | Red Cable |
| 2 | LED- | P | LED Cathode | White Cable |

2.3 U/D R/L Function Description

| Scan Control Input | | Scanning Direction |
|--------------------|------|---------------------------|
| UPDN | SHLR | |
| GND | VCC | Up to Down, Left to Right |
| VCC | GND | Down to Up, Right to Left |
| GND | GND | Up to Down, Right to Left |
| VCC | VCC | Down to Up, Left to Right |

The information contained herein is the exclusive property of TIANMA MICRO-ELECTRONICS Corporation, and shall not be distributed, reproduced, or disclosed in whole or in part without prior written permission of TIANMA MICRO-ELECTRONICS Corporation.

3 Absolute Maximum Ratings

AGND= GND=0V, Ta = 25°C

| Item | Symbol | Min | Max | Unit | Remark |
|---------------------------|------------------|--------|------|------|--------------|
| Power Voltage | VCC | -0.5 | 5.0 | V | |
| | AVDD | -0.5 | 13.5 | V | |
| | VGH | -0.3 | +42 | V | |
| | VGL | VGH-42 | +0.3 | V | |
| Backlight Forward Current | I _{LED} | - | 25 | mA | For each LED |
| Operating Temperature | T _{OPR} | -20 | 70 | °C | |
| Storage Temperature | T _{STG} | -30 | 80 | °C | |

For all inquiries, please contact: TIANMA Europe GmbH , Herrenalber Str. 22, 76199 ,
Karlsruhe,Germany,Tel: 49 (721) 89311-0, Email: Info@tianma.eu

4 Electrical Characteristics

4.1 Recommended Operating Condition

AGND=GND=0V, Ta = 25°C

| Item | Symbol | Min | Typ | Max | Unit | Remark |
|---------------------------------|--------|------|------|------|------|--------|
| Digital Supply Voltage | VCC | 2.8 | 3.3 | 3.6 | V | |
| Analog Supply Voltage | AVDD | 12.3 | 12.5 | 12.7 | V | |
| Gate On Voltage | VGH | 20.8 | 22 | 23.3 | V | |
| Gate Off Voltage | VGL | -7.5 | -7.0 | -6.5 | V | |
| Common Electrode Driving Signal | VCOM | 3.3 | 3.4 | 3.5 | V | |

Note: The value is for design stage only.

4.2 Recommended Driving Condition for Backlight

Ta=25°C

| Item | Symbol | Min | Typ | Max | Unit | Remark |
|-----------------------------|----------|--------|------|------|------|---|
| Forward Current | I_F | - | 20 | 25 | mA | 30 LEDs (3 LED Serial, 10 LED Parallel) |
| Forward Voltage | V_F | - | 9.6 | 10.3 | V | |
| Backlight Power Consumption | W_{BL} | - | 1.92 | 2.55 | W | |
| Operating Life Time | - | 20,000 | - | - | Hrs | $I_F = 20mA$ |

Note1: The LED driving condition is defined for each LED module (3 LED Serial, 10 LED Parallel).For each LED: $I_F (1/10) = 20mA$, $V_F (1/3) = 3.2V$.

Note2: Under LCM operating, the stable forward current should be inputted. And forward voltage is for reference only.

Note3: I_F is defined for one channel LED.Optical performance should be evaluated at Ta=25°C only If LED is driven by high current, high ambient temperature & humidity condition. The life time of LED will be reduced.Operating life means brightness goes down to 50% initial brightness. Typical operating life time is estimated data.

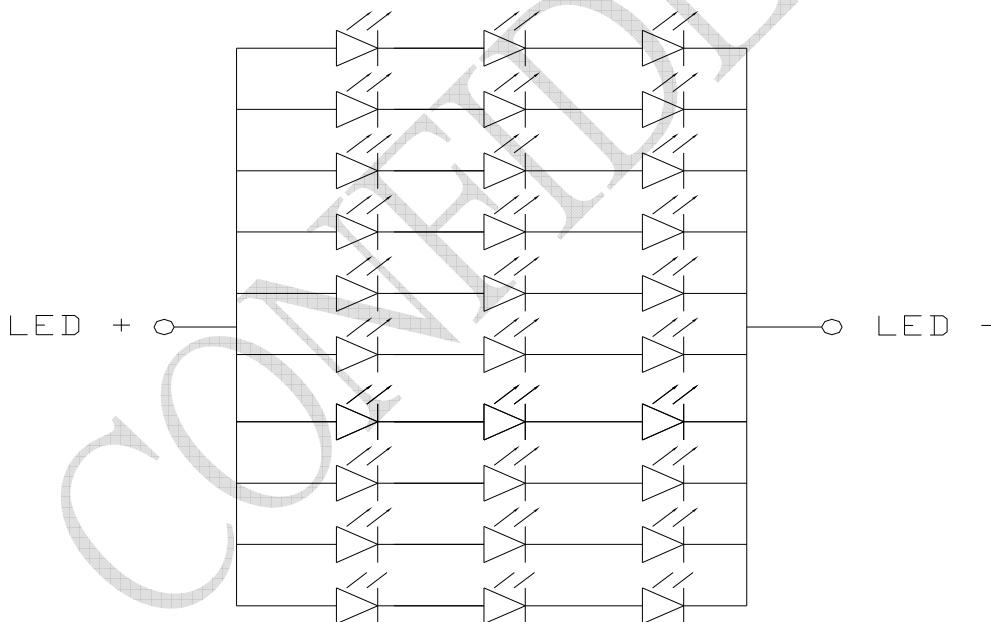

Note4: The LED driving condition is defined for each LED module.

For all inquiries, please contact: TIANMA Europe GmbH , Herrenalber Str. 22, 76199 , Karlsruhe,Germany,Tel: 49 (721) 89311-0, Email: Info@tianma.eu

4.3 Power Consumption

AGND=GND=0V, Ta = 25°C

| Item | Symbol | Condition | Min | Typ | Max | Unit | Remark |
|------------------------|-------------------|------------|-----|-------|-------|------|--------|
| Digital Supply Current | I _{VCC} | VCC=3.3V | - | 3.39 | 9.62 | mA | |
| Analog Supply Current | I _{AVDD} | AVDD=12.5V | - | 17.75 | 27.24 | mA | |
| Gate On Current | I _{VGH} | VGH=22.0V | - | 0.28 | 0.31 | mA | |
| Gate Off Current | I _{VGL} | VGL=-7.0V | - | 0.29 | 0.32 | mA | |
| Power Consumption | Panel&Gamma | | - | 241.4 | 381.5 | mW | |
| | Backlight | | - | 1.92 | - | W | |
| | Total | | - | 1.969 | 2.110 | W | |

4.4 Block Diagram

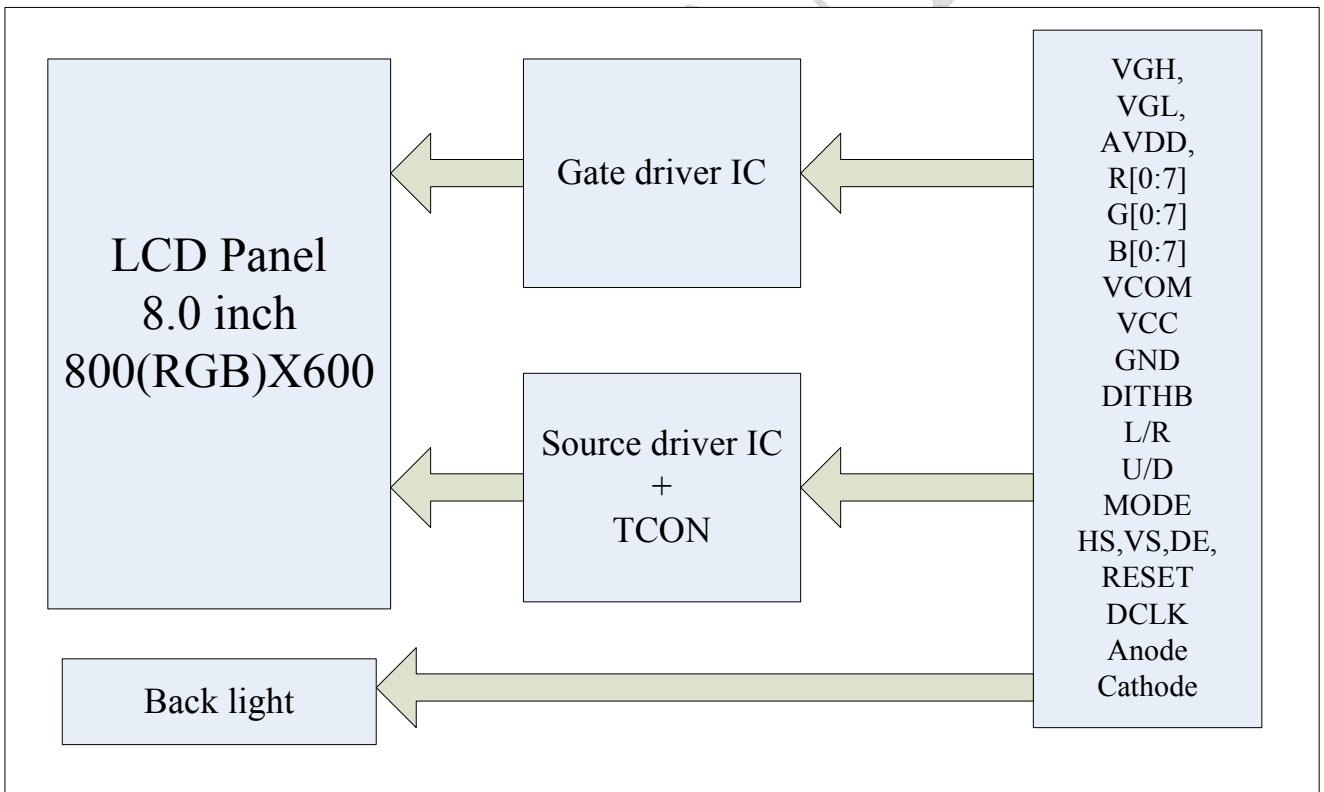

For all inquiries, please contact: TIANMA Europe GmbH , Herrenalber Str. 22, 76199 , Karlsruhe,Germany,Tel: 49 (721) 89311-0, Email: Info@tianma.eu

5 Timing Chart

5.1 TFT-LCD Input Timing

VCC=3.3V, AVDD=12.5V, AGND=GND=0V, Ta=25°C

| Parameter | Symbol | Min | Typ | Max | Unit | Conditions |
|------------------|--------|-----|-----|-----|------|--------------|
| DCLK Frequency | Fclk | - | 40 | 50 | MHz | |
| DCLK Cycle Time | Tcph | 20 | 25 | - | ns | |
| DCLK Pulse Width | Tcw | 40% | 50% | 60% | Tcph | |
| VSD Setup Time | Tvst | 8 | - | - | ns | |
| VSD Hold Time | Tvhd | 8 | - | - | ns | |
| HSD Setup Time | Thst | 8 | - | - | ns | |
| HSD Hold Time | Thhd | 8 | - | - | ns | |
| Data Setup Time | Tdsu | 8 | - | - | ns | Data to DCLK |
| Data Hold Time | Tdhd | 8 | - | - | ns | Data to DCLK |
| DE Setup Time | Tesu | 8 | - | - | ns | |
| DE Hold Time | Tehd | 8 | - | - | ns | |

Input Clock and Data timing Diagram:

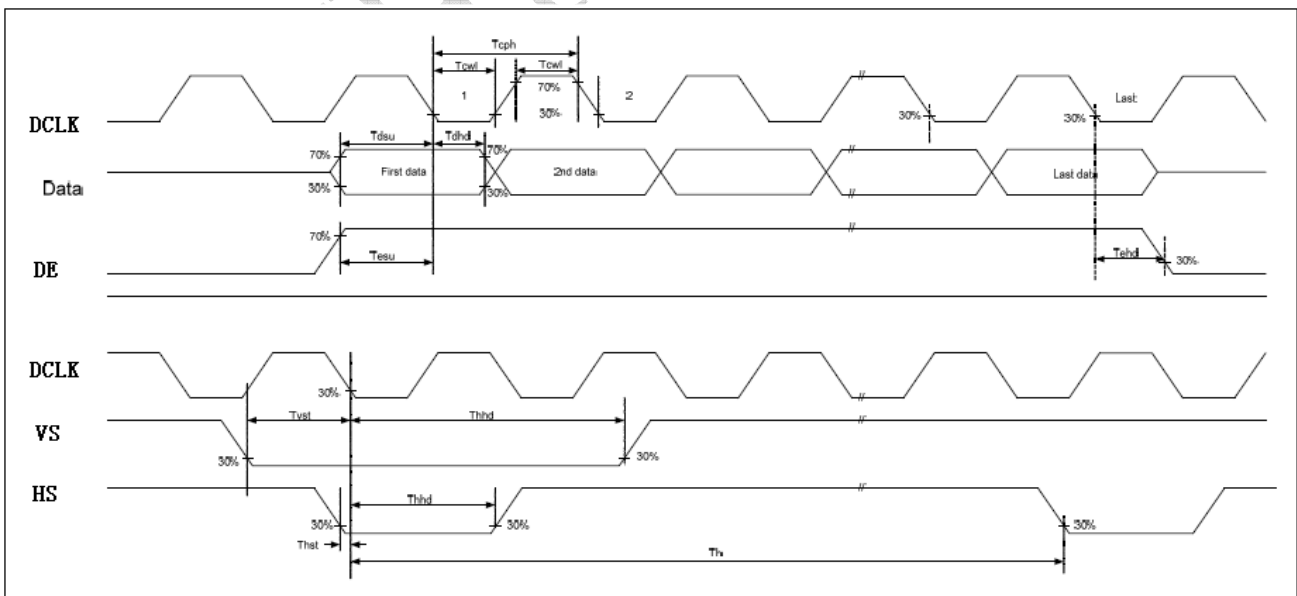

The information contained herein is the exclusive property of TIANMA MICRO-ELECTRONICS Corporation, and shall not be distributed, reproduced, or disclosed in whole or in part without prior written permission of TIANMA MICRO-ELECTRONICS Corporation.

For all inquiries, please contact: TIANMA Europe GmbH , Herrenalber Str. 22, 76199 , Karlsruhe, Germany, Tel: 49 (721) 89311-0, Email: Info@tianma.eu

5.2 Recommended Timing Setting Of TCON

TCON (Embedded In Source IC) Input Timing (DCLK, HSD, VSD, DE)

VCC=3.3V, AVDD=12.5V, AGND=GND=0V, Ta=25°C

| Parameter | Symbol | Min | Typ | Max | Unit | Remark |
|-----------|--------|-----|------|-----|------|--------|
| DCLK | Fclk | - | 40 | 50 | MHZ | |
| | tclk | 20 | 25 | - | ns | |
| HSD | th | - | 1000 | - | tclk | |
| | thd | - | 800 | - | tclk | |
| | thpw | 1 | 48 | - | tclk | |
| | thb | - | 88 | - | tclk | |
| | thfp | - | 112 | - | tclk | |
| VSD | tv | - | 660 | - | th | |
| | tvd | - | 600 | - | th | |
| | tvpw | - | 3 | - | th | |
| | tvb | - | 39 | - | th | |
| | tvfp | - | 21 | - | th | |

Note: DE timing refer to HSD, VSD input timing.

Vertical input timing Diagram:

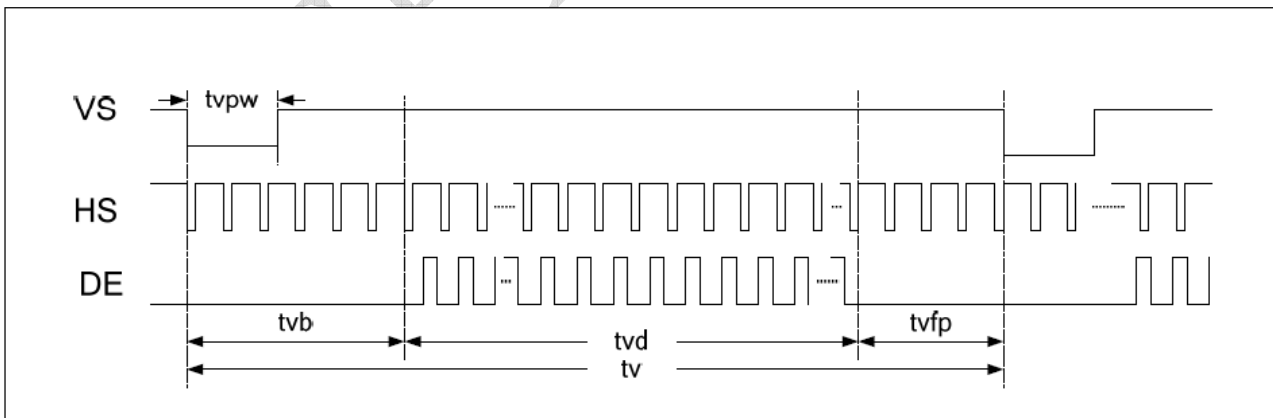

For all inquiries, please contact: **TIANMA Europe GmbH** , Herrenalber Str. 22, 76199 , Karlsruhe, Germany, Tel: 49 (721) 89311-0, Email: Info@tianma.eu

Horizontal input timing Diagram:

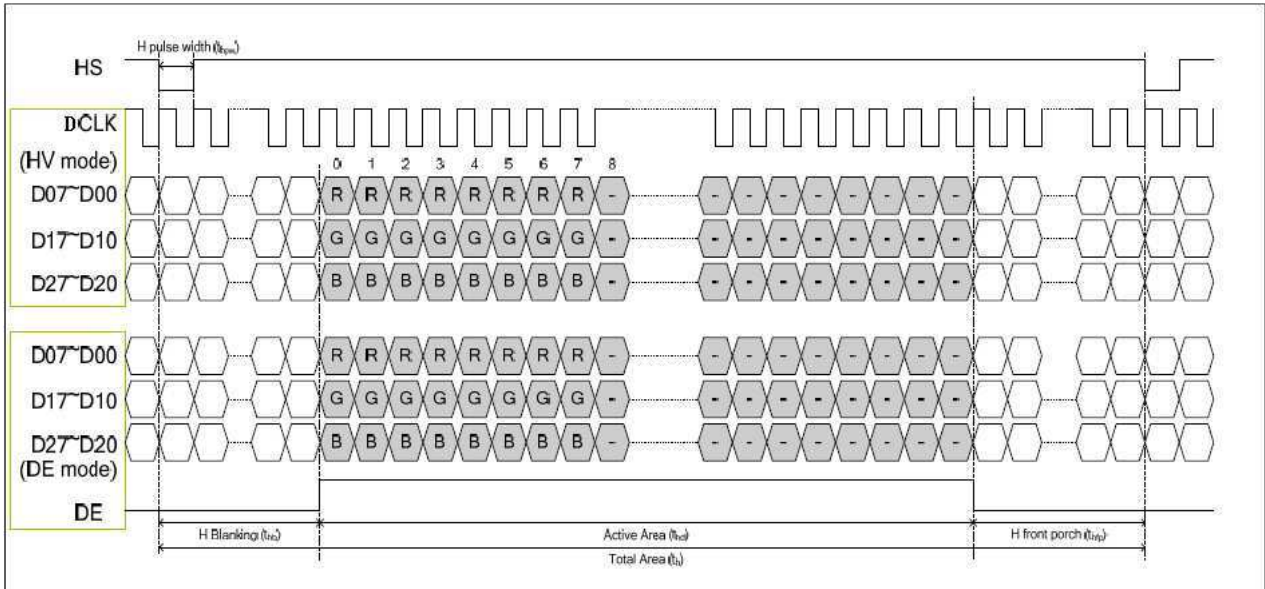

5.3 POWER ON/OFF SEQUENCE

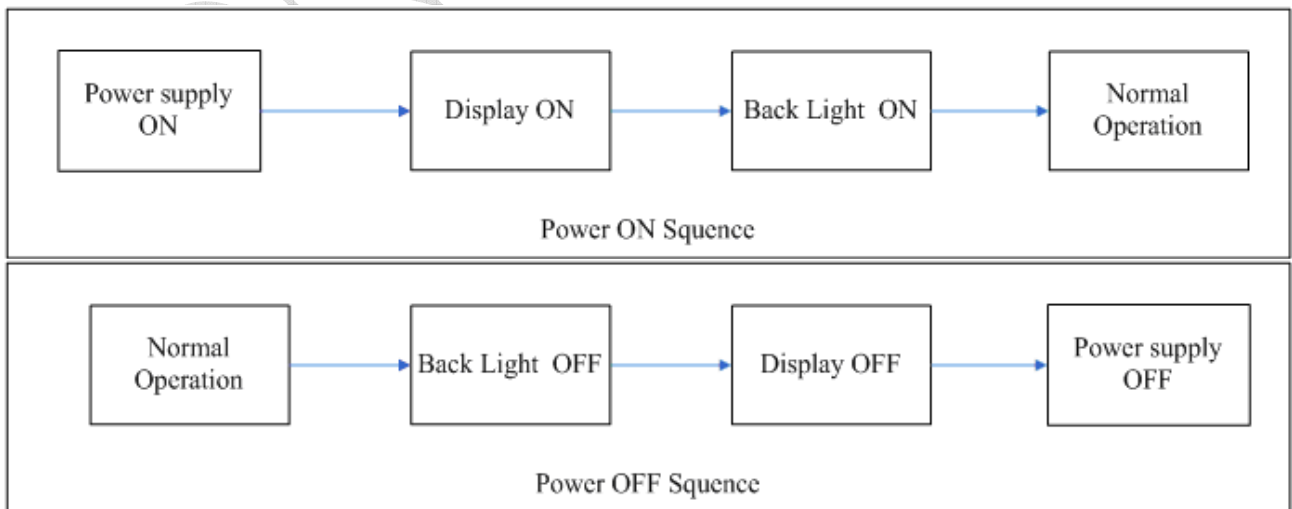
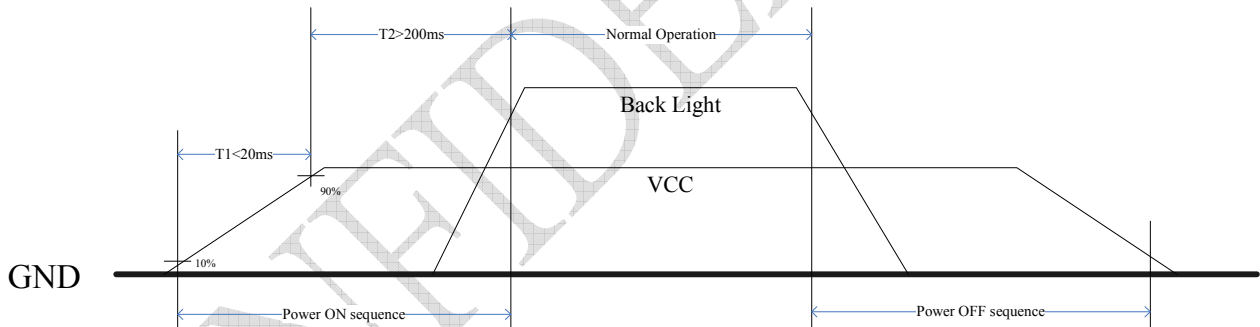

The information contained herein is the exclusive property of TIANMA MICRO-ELECTRONICS Corporation, and shall not be distributed, reproduced, or disclosed in whole or in part without prior written permission of TIANMA MICRO-ELECTRONICS Corporation.

6 Optical Characteristics

Ta=25°C

| Item | Symbol | Condition | Min | Typ | Max | Unit | Remark |
|----------------|------------|------------------|--------------------|-------|-------|-------------------|----------------|
| View Angles | θT | $CR \geq 10$ | 40 | 50 | - | Degree | Note 2 |
| | θB | | 60 | 70 | - | | |
| | θL | | 60 | 70 | - | | |
| | θR | | 60 | 70 | - | | |
| Contrast Ratio | CR | $\theta=0^\circ$ | 400 | 500 | - | | Note1 Note3 |
| Response Time | T_{ON} | 25°C | - | 25 | 30 | ms | Note1 Note4 |
| | T_{OFF} | | | | | | |
| Chromaticity | White | x | Backlight is on | 0.260 | 0.310 | 0.360 | Note1 Note5 |
| | | y | | 0.280 | 0.330 | 0.380 | |
| | Red | x | | 0.541 | 0.591 | 0.641 | |
| | | y | | 0.300 | 0.350 | 0.400 | |
| | Green | x | | 0.299 | 0.349 | 0.399 | |
| | | y | | 0.520 | 0.570 | 0.620 | |
| | Blue | x | | 0.101 | 0.151 | 0.201 | |
| | | y | | 0.047 | 0.097 | 0.147 | |
| Uniformity | U | | 70 | 75 | - | % | Note1 Note6 |
| NTSC | | | 45 | 50 | - | % | Note 5 |
| Luminance | L | | 450 | 500 | - | cd/m ² | Note1 Note7 |

Test Conditions:

1. $I_F=20mA$, $V_F=9.6V$, and the ambient temperature is 25°C.
2. The test systems refer to Note 1 and Note 2.

For all inquiries, please contact: TIANMA Europe GmbH , Herrenalber Str. 22, 76199 , Karlsruhe, Germany, Tel: 49 (721) 89311-0, Email: Info@tianma.eu

Note 1: Definition of optical measurement system.

The optical characteristics should be measured in dark room. After 5 Minutes operation, the optical properties are measured at the center point of the LCD screen. All input terminals LCD panel must be ground when measuring the center area of the panel.

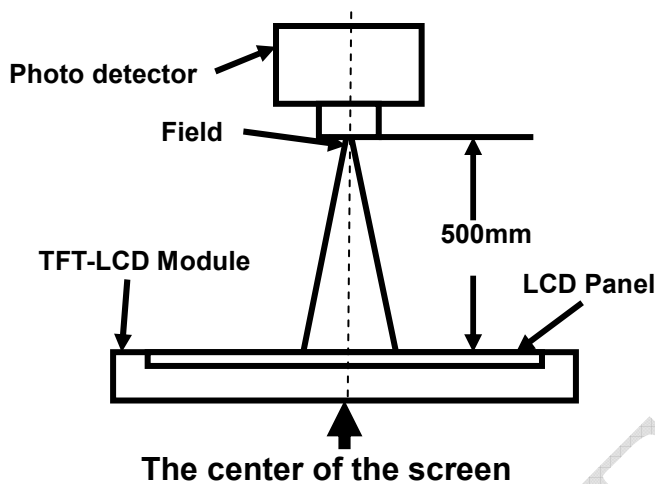

| Item | Photo detector | Field |
|----------------|----------------|-------|
| Contrast Ratio | BM-5A | 1° |
| Luminance | | |
| Lum Uniformity | | |
| Chromaticity | SR-3A | |
| Response Time | TRD100 | - |

Note 2: Definition of viewing angle range and measurement system.

viewing angle is measured at the center point of the LCD by CONOSCOPE(ergo-80).

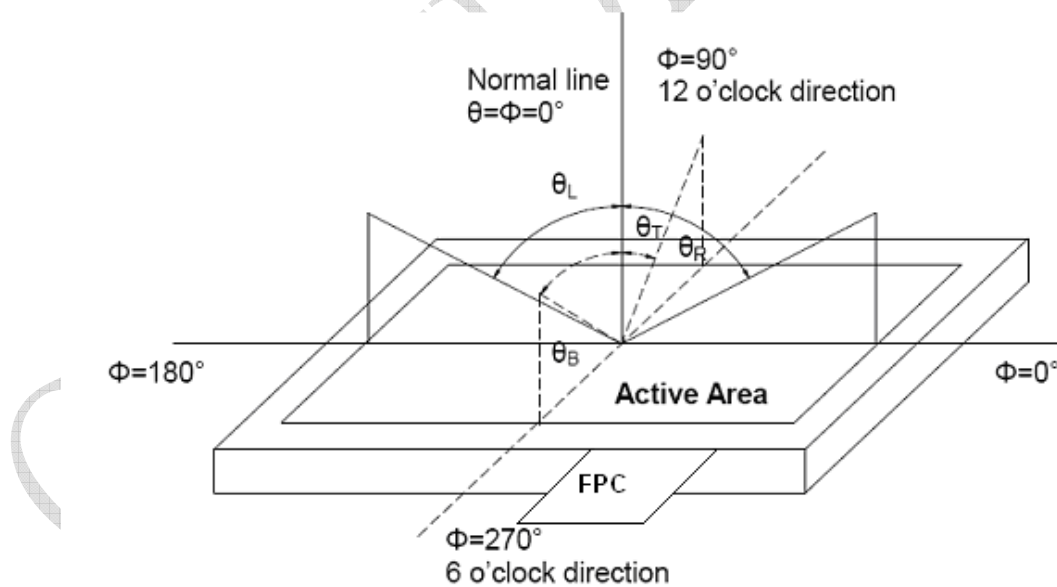

Note 3: Definition of contrast ratio

$$\text{Contrast ratio (CR)} = \frac{\text{Luminance measured when LCD is on the "White" state}}{\text{Luminance measured when LCD is on the "Black" state}}$$

“White state “: The state is that the LCD should drive by Vwhite.

For all inquiries, please contact: TIANMA Europe GmbH , Herrenalber Str. 22, 76199 , Karlsruhe, Germany, Tel: 49 (721) 89311-0, Email: Info@tianma.eu

“Black state”: The state is that the LCD should drive by Vblack.

Vwhite: To be determined Vblack: To be determined.

Note 4: Definition of Response time

The response time is defined as the LCD optical switching time interval between “White” state and “Black” state. Rise time (T_{ON}) is the time between photo detector output intensity changed from 90% to 10%. And fall time (T_{OFF}) is the time between photo detector output intensity changed from 10% to 90%.

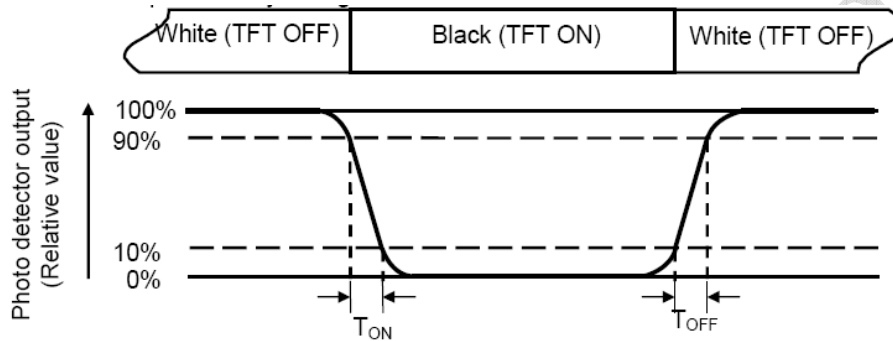

Note 5: Definition of color chromaticity (CIE1931)

Color coordinates measured at center point of LCD.

Note 6: Definition of Luminance Uniformity

Active area is divided into 9 measuring areas (Refer Fig. 2). Every measuring point is placed at the center of each measuring area.

$$\text{Luminance Uniformity (U)} = L_{\min} / L_{\max}$$

L-----Active area length W----- Active area width

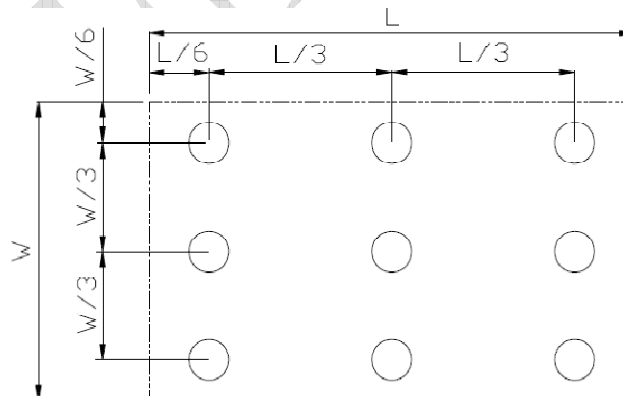

L_{\max} : The measured Maximum luminance of all measurement position.

L_{\min} : The measured Minimum luminance of all measurement position.

Note 7: Definition of Luminance:

Measure the luminance of white state at center point.

For all inquiries, please contact: TIANMA Europe GmbH , Herrenalber Str. 22, 76199 ,
 Karlsruhe,Germany,Tel: 49 (721) 89311-0, Email: Info@tianma.eu

7 Environmental / Reliability Test

| No | Test Item | Condition | Remarks |
|----|--|--|---|
| 1 | High Temperature Operation | Ts = +70°C, 240 hours (Note1) | IEC60068-2-1:2007 GB2423.2-2008 |
| 2 | Low Temperature Operation | Ta = -20°C, 240 hours (Note2) | IEC60068-2-1:2007 GB2423.1-2008 |
| 3 | High Temperature Storage | Ta = +80°C, 240 hours | IEC60068-2-1:2007 GB2423.2-2008 |
| 4 | Low Temperature Storage | Ta = -30°C, 240 hours | IEC60068-2-1:2007 GB2423.1-2008 |
| 5 | Storage at High Temperature and Humidity | Ta = +60°C, 90% RH max,240hours | IEC60068-2-78 :2001 GB/T2423.3—2006 |
| 6 | Thermal Shock (non-operation) | -30°C 30 min~+80°C 30 min, Change time:5min, 20 Cycle | Start with cold temperature, End with high temperature, IEC60068-2-14:1984,G B2423.22-2002 |
| 7 | ESD | C=150pF,R=330Ω,5point/panel Air:±8Kv,5times; Contact:±4Kv,5times (Environment:15°C~35°C, 30%~60%.86Kpa~106Kpa) | IEC61000-4-2:2001 GB/T17626.2-2006 |
| 8 | Vibration Test | Frequency range:10~55Hz Stroke:1.5mm Sweep:10Hz~55Hz~10Hz 2 hours for each direction of X.Y.Z. (6 hours for total) | IEC60068-2-6:1982 GB/T2423.10—1995 |
| 9 | Mechanical Shock (Non Op) | Half Sine Wave 60G 6ms, ±X,±Y,±Z 3times for each direction | IEC60068-2-27:1987 GB/T2423.5—1995 |
| 10 | Package Drop Test | Height:80cm, 1corner,3edges,6surfaces | IEC60068-2-32:1990 GB/T2423.8—1995 |

Note1: Ts is the temperature of panel's surface.

Note2: Ta is the ambient temperature of samples.

9 Packing drawing

| No | Item | Model (Material) | Dimensions(mm) | Unit Weight(Kg) | Quantity | Remark | | | | | | | | | | | | | | |
|----|-----------------|------------------|-----------------|-----------------|----------|-------------|--------|------------------|-------------|------|---|--|---|--------------|-----------|--|--|--|--|--|
| 1 | LCM module | TM080SDHG02-00 | 183.0X141.0X5.6 | 0.25 | 48 | | | | | | | | | | | | | | | |
| 2 | Partition_1 | Corrugated paper | 527X348X217 | 1.571 | 1 | | | | | | | | | | | | | | | |
| 3 | Anti-static Bag | PE | 161X253X0.05 | 0.001 | 48 | Anti-static | | | | | | | | | | | | | | |
| 4 | Dust-Proof Bag | PE | 700X545 | 0.06 | 1 | | | | | | | | | | | | | | | |
| 5 | Partition_2 | Corrugated Paper | 505X332X4.0 | 0.098 | 2 | | | | | | | | | | | | | | | |
| 6 | Corrugated Bar | Corrugated paper | 348X173 | 6 | | 7 | Carton | Corrugated paper | 544X365X250 | 1.12 | 1 | | 8 | Total weight | 15.337±5% | | | | | |
| 7 | Carton | Corrugated paper | 544X365X250 | 1.12 | 1 | | | | | | | | | | | | | | | |
| 8 | Total weight | 15.337±5% | | | | | | | | | | | | | | | | | | |

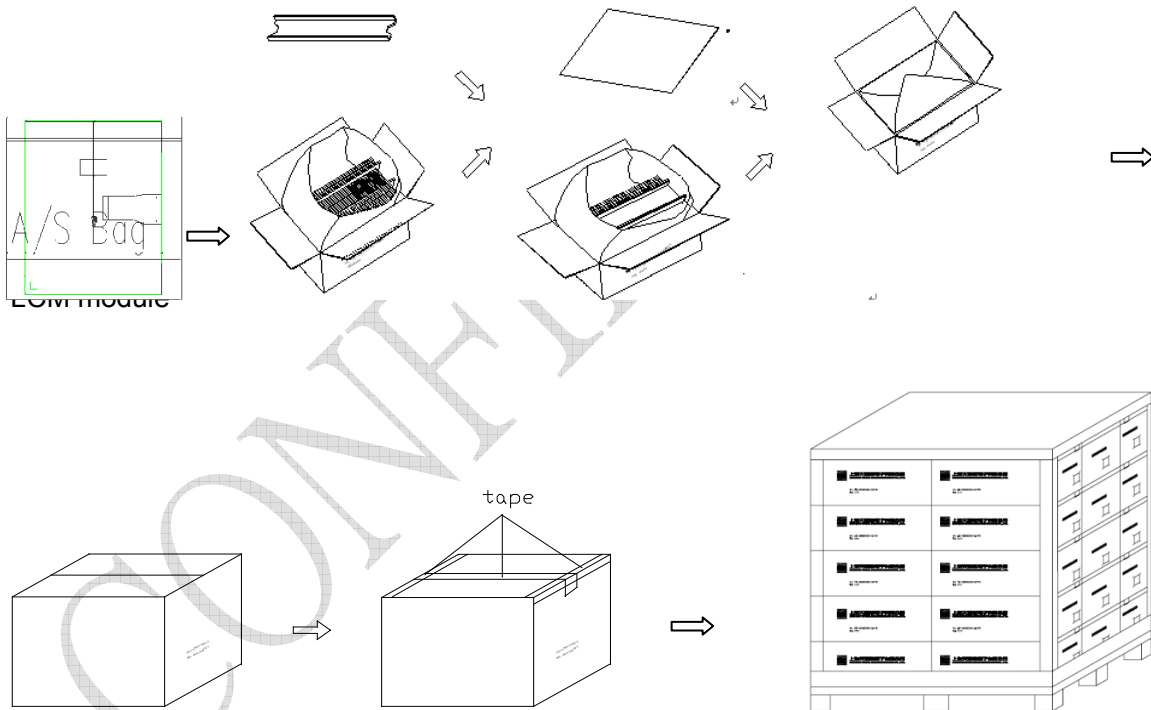

10 Precautions for Use of LCD Modules

10.1 Handling Precautions

10.1.1 The display panel is made of glass. Do not subject it to a mechanical shock by dropping it from a high place, etc.

10.1.2 If the display panel is damaged and the liquid crystal substance inside it leaks out, be sure not to get any in your mouth, if the substance comes into contact with your skin or clothes, promptly wash it off using soap and water.

10.1.3 Do not apply excessive force to the display surface or the adjoining areas since this may cause the color tone to vary.

10.1.4 The polarizer covering the display surface of the LCD module is soft and easily scratched. Handle this polarizer carefully.

10.1.5 If the display surface is contaminated, breathe on the surface and gently wipe it with a soft dry cloth. If still not completely clear, moisten cloth with one of the following solvents:

- Isopropyl alcohol
- Ethyl alcohol

Solvents other than those mentioned above may damage the polarizer. Especially, do not use the following:

- Water
- Ketone
- Aromatic solvents

10.1.6 Do not attempt to disassemble the LCD Module.

10.1.7 If the logic circuit power is off, do not apply the input signals.

10.1.8 To prevent destruction of the elements by static electricity, be careful to maintain an optimum work environment.

10.1.8.1 Be sure to ground the body when handling the LCD Modules.

10.1.8.2 Tools required for assembly, such as soldering irons, must be properly ground.

10.1.8.3 To reduce the amount of static electricity generated, do not conduct assembly and other work under dry conditions.

10.1.8.4 The LCD Module is coated with a film to protect the display surface. Be care when peeling off this protective film since static electricity may be generated.

10.2 Storage precautions

10.2.1 When storing the LCD modules, avoid exposure to direct sunlight or to the light of fluorescent lamps.

10.2.2 The LCD modules should be stored under the storage temperature range. If the LCD modules will be stored for a long time, the recommend condition is: Temperature : 0°C ~ 40°C, Relatively humidity: ≤80%

10.2.3 The LCD modules should be stored in the room without acid, alkali and harmful gas.

For all inquiries, please contact: TIANMA Europe GmbH , Herrenalber Str. 22, 76199 ,
Karlsruhe,Germany,Tel: 49 (721) 89311-0, Email: Info@tianma.eu

10.3 Transportation Precautions

10.3.1 The LCD modules should be no falling and violent shocking during transportation, and also should avoid excessive press, water, damp and sunshine.

CONFIDENTIAL