



MODEL NO. : TM070RDH10-20

ISSUED DATE: 2011-10-27

VERSION : Ver 1.1

- Preliminary Specification
- Final Product Specification

Customer : _____

Approved by	Notes

SHANGHAI TIANMA Confirmed :

SHANGHAI TIANMA Confirmed :

Prepared by	Checked by	Approved by
邓晓平	许明	[Signature]

This technical specification is subjected to change without notice

The information contained herein is the exclusive property of SHANGHAI AVIC OPTOELECTRONICS Corporation, and shall not be distributed, reproduced, or disclosed in whole or in part without prior written permission of SHANGHAI AVIC OPTOELECTRONICS Corporation.



Table of Contents

Table of Contents.....	2
Record of Revision.....	3
1 General Specifications.....	4
2 Input/Output Terminals.....	5
3 Absolute Maximum Ratings.....	6
4 Electrical Characteristics.....	8
5 Timing Chart.....	11
6 Optical Characteristics.....	14
7 Environmental / Reliability Test.....	17
8 Mechanical Drawing.....	18
9 Packing drawing.....	19
10 Precautions for Use of LCD Modules.....	20

TIANMA CONFIDENTIAL



1 General Specifications

Feature		Spec
Display Spec.	Size	7.0 inch
	Resolution	800(RGB) x 480
	Interface	RGB 24 bits with TCON
	Color Depth	16M
	Technology Type	a-Si TFT
	Pixel Pitch (mm)	0.1926 (H) x 0.179(V)
	Pixel Configuration	R.G.B. Vertical Stripe
	Display Mode	TM,NW
	Surface Treatment	Anti Glare
	Viewing Direction	12 o'clock
	Gray Scale Inversion Direction	6 o'clock
Mechanical Characteristics	LCM (W x H x D) (mm)	164.9x 100 x 5.7
	Active Area(mm)	154.08 (W) x 85.92 (H)
	With /Without TSP	Without TSP
	Weight (g)	TBD
	LED Numbers	24 LEDS

Note 1: Viewing direction for best image quality is different from TFT definition. There is a 180 degree shift.

Note 2: Requirements on Environmental Protection: Q/S0002

Note 3: LCM weight tolerance: +/- 5%



2 Input/Output Terminals

2.1 CN1 of FPC

PIN	Symbol	I/O	Description	Remark
1	VLED+	P	Led anode	
2	VLED+	P	Led anode	
3	VLED-	P	Led cathode	
4	VLED-	P	Led cathode	
5	GND	P	Ground	
6	VCOM	P	Common voltage input	
7	VCC	P	Digital power supply	
8	MODE	I	DE/SYNC mode select. H:DE mode, L:SYNC mode	
9	DE	I	Data enable signal, active high to enable data	
10	VSYNC	I	Vertical sync input, negative polarity	
11	HSYNC	I	Horizontal sync input, negative polarity	
12	B7	I	Blue data (MSB)	
13	B6	I	Blue data	
14	B5	I	Blue data	
15	B4	I	Blue data	
16	B3	I	Blue data	
17	B2	I	Blue data	
18	B1	I	Blue data	
19	B0	I	Blue data (LSB)	
20	G7	I	Green data (MSB)	
21	G6	I	Green data	
22	G5	I	Green data	
23	G4	I	Green data	
24	G3	I	Green data	
25	G2	I	Green data	
26	G1	I	Green data	
27	G0	I	Green data (LSB)	
28	R7	I	Red data (MSB)	
29	R6	I	Red data	
30	R5	I	Red data	
31	R4	I	Red data	
32	R3	I	Red data	
33	R2	I	Red data	
34	R1	I	Red data	
35	R0	I	Red data (LSB)	
36	GND	P	Ground	
37	DCLK	I	Clock for input data	
38	GND	P	Ground	
39	LR	I	Source left or right sequence control	
40	UD	I	Gate up or down scan control	
41	VGH	P	Positive power of TFT	
42	VGL	P	Negative power of TFT	
43	AVDD	P	Analog power supply	

The information contained herein is the exclusive property of SHANGHAI AVIC OPTOELECTRONICS Corporation, and shall not be distributed, reproduced, or disclosed in whole or in part without prior written permission of SHANGHAI AVIC OPTOELECTRONICS Corporation.



44	RESET	I	Global reset pin
45	NC	NC	
46	VCOM	P	Common voltage input
47	DITHB	I	Dithering setting. H: 6bit resolution, L: 8bit resolution
48	GND	P	Ground
49	NC	NC	
50	NC	NC	

I---Input, O---Output, P--- Power/Ground

Table 2.1 terminal pin assignments

2.2 U/D R/L Function Description

Scan control input		Scanning direction
UD	LR	
GND	VCC	Up to down, left to right
VCC	GND	Down to up, right to left
GND	GND	Up to down, right to left
VCC	VCC	Down to up, left to right



3 Absolute Maximum Ratings

Ta = 25°C

Item	Symbol	MIN	MAX	Unit	Remark
Power Voltage	VCC	-0.50	5.00	V	
	AVDD	-0.50	15.00	V	
	VGH	-0.30	42.00	V	
	VGL	-20.00	0.30	V	
	VGH-VGL	-0.30	40.00	V	
Operating Temperature	T _{op}	-20.0	70.0	°C	
Storage Temperature	T _{st}	-30.0	80.0	°C	
Operating and Storage Humidity	HSTG	10%	90%	% (RH)	

Table 3.1 absolute maximum rating

TIANMA CONFIDENTIAL



4 Electrical Characteristics

4.1 Recommended Operating Condition

VCC=3.3V, GND=0V, Ta = 25°C

Item	Symbol	MIN	TYP	MAX	Unit	Remark	
Digital supply Voltage	VCC	3.00	3.30	3.60	V		
Analog supply Voltage	AVDD	9.88	10.4	10.92	V		
Gate on voltage	VGH	14.4	16	17.6	V		
Gate off voltage	VGL	-7.70	-7.00	-6.30	V		
Common Electrode Driving Signal	VCOM	3.68	3.70	3.72	V		
Input Signal Voltage	Low Level	V _{IL}	0	-	0.3xVCC	V	R0~R7, G0~G7, 0~B7, DE, DCLK, HSYNC, VSYNC, MODE, RESET, LR, UD, DITHB
	High Level	V _{IH}	0.7xVCC	-	VCC	V	
Current of digital supply voltage	I _{VCC}	-	-	10	mA	VCC=3.3V,colorbar pattern	
Current of analog supply voltage	I _{AVDD}	-	-	30	mA		
Current of Gate on voltage	I _{VGH}	-	-	0.3	mA	VGH=22.0V	
Current of Gate off voltage	I _{VGL}	-	-	0.3	mA	VGL=-7.0V	
Current of Vcom	I _{vcom}			10	mA		

Table 4.1 LCD module electrical characteristics

Note 1: the value is for design stage only.



4.2 Backlight Unit Driving Condition

Item	Symbol	MIN	TYP	MAX	Unit	Remark
Forward Current	I_F	-	160.0	200	mA	24 LEDs (3 LED Serial, 8 LED Parallel)
Forward Current Voltage	V_F	-	9.6	10.8	V	
Backlight Power Consumption	W_{BL}	-	1536	2160	mW	
Operating Life Time	--	10000	(20000)	--	hrs	Note 2, Note 3

Note1: The LED driving condition is defined for each LED module (3 LED Serial, 8 LED Parallel).

Note2: Under LCM operating, the stable forward current should be inputted. And forward voltage is for reference only.

Note3: Optical performance should be evaluated at $T_a=25^\circ\text{C}$ only If LED is driven by high current, high ambient temperature & humidity condition. The life time of LED will be reduced. Operating life means brightness goes down to 50% initial brightness. Typical operating life time is estimated data.

Note4: The LED driving condition is defined for each LED module.

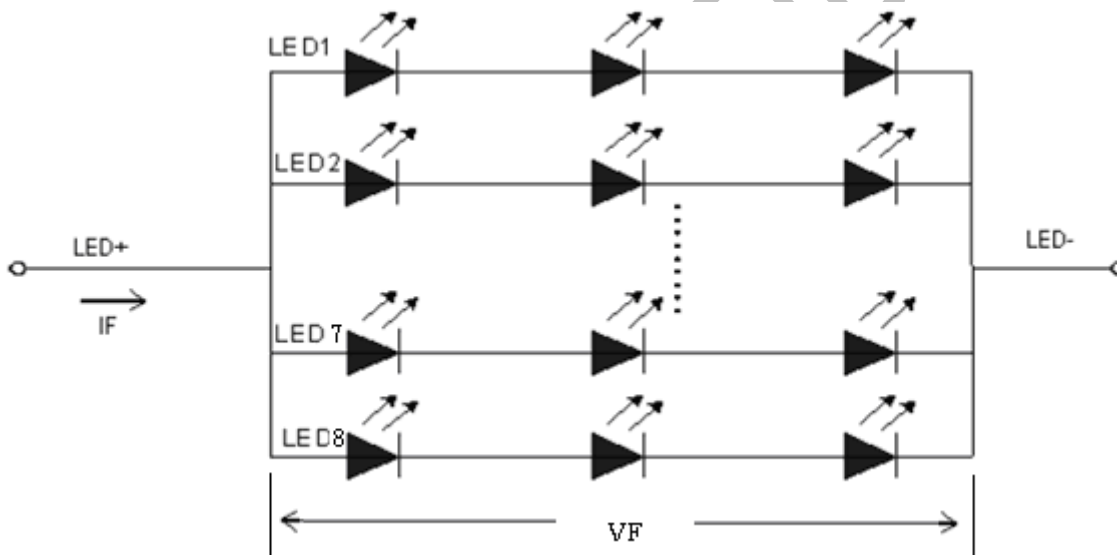



4.3 BLOCK DIAGRAM

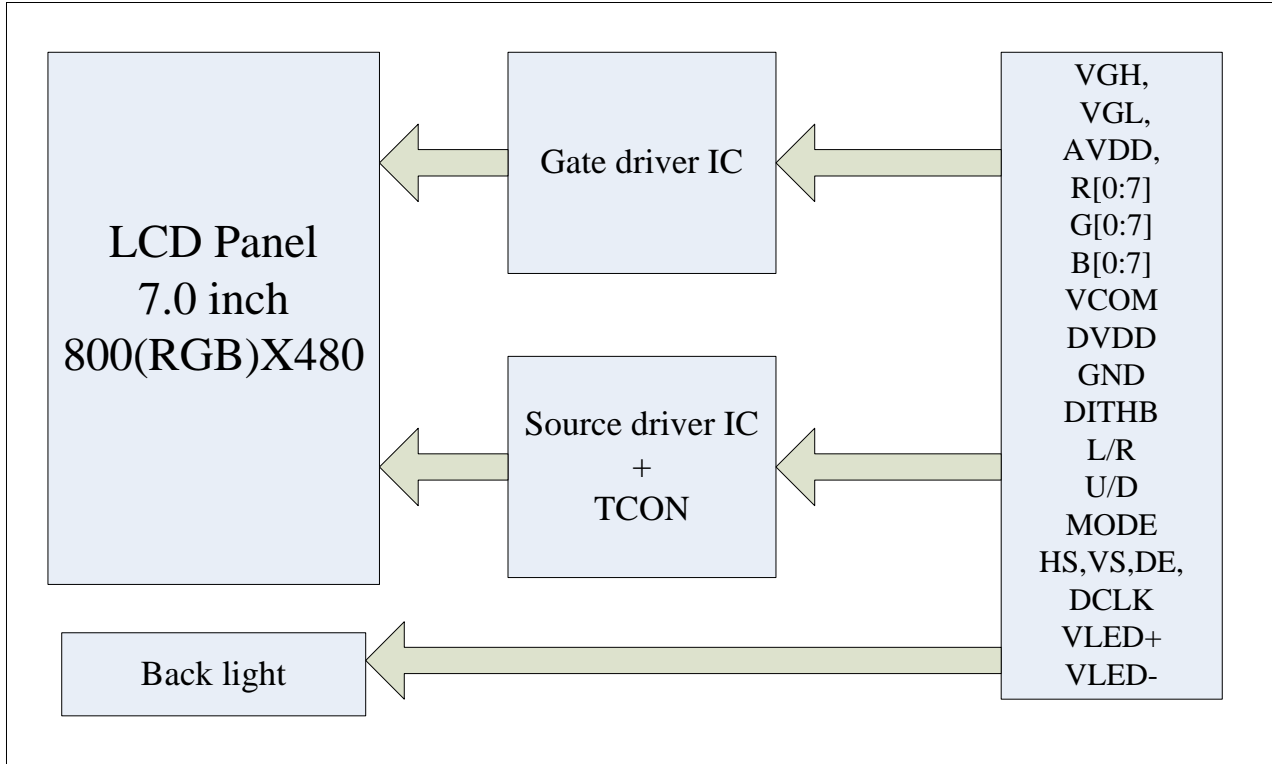

TIANMA.COM



5 Timing Chart

5.1 TFT-LCD Input Timing

VCC=3.3V, GND=0V, Ta=25°C

Parameter	Symbol	Min	Typ	Max	Unit	Remark
DCLK frequency	F_{clk}	28	30.0	40.0	MHz	
DCLK cycle time	T_{cph}	25	33.3	36	ns	
DCLK pulse width	T_{cw}	40%	50%	60%	T_{cph}	
VS setup time	T_{vst}	8			ns	
VS hold time	T_{vhd}	8	-	-	ns	
HS setup time	T_{hst}	8			ns	
HS hold time	T_{hhd}	8	-	-	ns	
Data setup time	T_{dsu}	8			ns	Data to DCLK
Data hold time	T_{dhd}	8	-	-	ns	Data to DCLK
DE setup time	T_{esu}	8	-	-	ns	
DE hold time	T_{ehd}	8	-	-	ns	

Input Clock and Data timing Diagram:

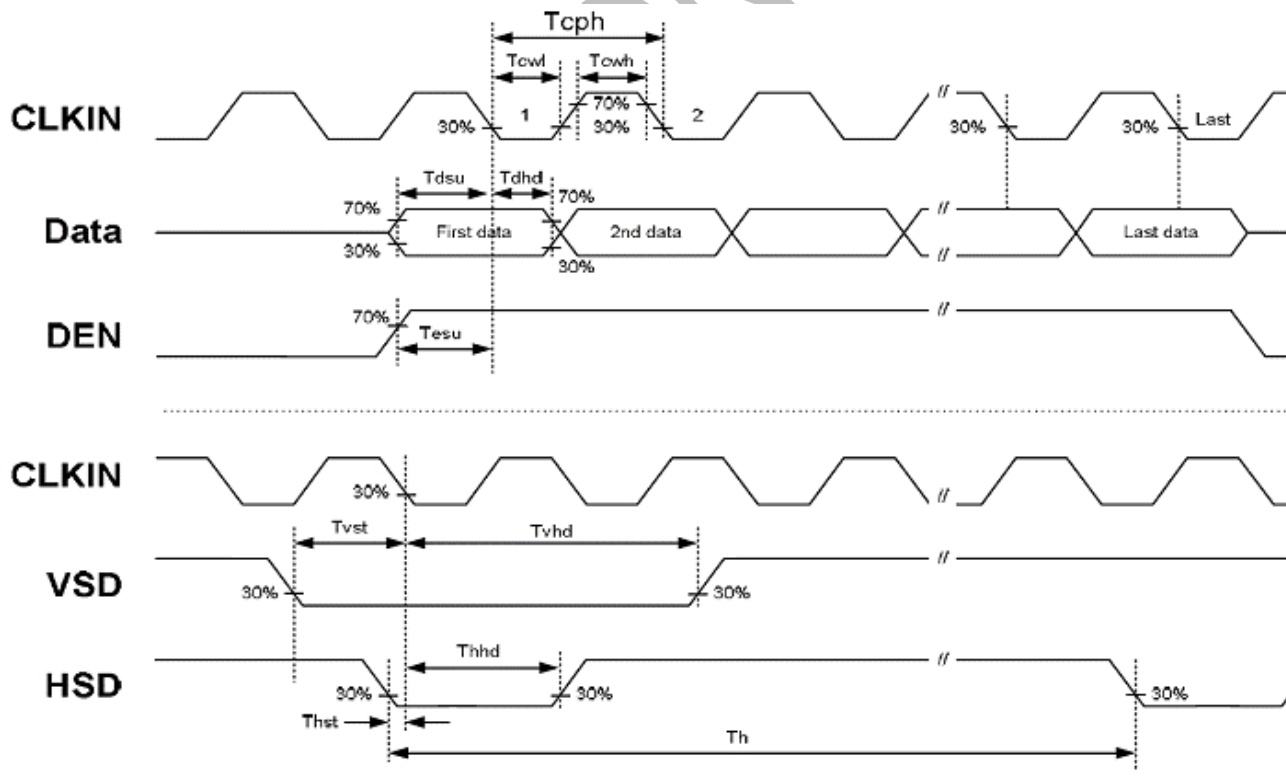

The information contained herein is the exclusive property of SHANGHAI AVIC OPTOELECTRONICS Corporation, and shall not be distributed, reproduced, or disclosed in whole or in part without prior written permission of SHANGHAI AVIC OPTOELECTRONICS Corporation.



5.2 Recommended Timing Setting Of TCON

TCON (Embedded In Source IC) Input Timing (DCLK, HS, VS, DE)

VCC=3.3V, GND=0V, Ta=25°C

Parameter	Symbol	Min	Typ	Max	Unit	Remark
DCLK	Fclk	28	30	40	MHZ	
	tclk	20	33.3	36	ns	
HSD	th	862	1056	1200	tclk	
	thd	800	800	800	tclk	
	thpw	1	-	40	tclk	
	thb	46	46	46	tclk	
	thfp	16	210	354	tclk	
VSD	tv	510	525	650	th	
	tvd	480	480	480	th	
	tvpw	1	3	20	th	
	tvb	23	23	23	th	
	tvfp	7	22	147	th	

Note 1: DE timing refer to HS, VS input timing.

TCON Vertical Input Timing Diagram HV

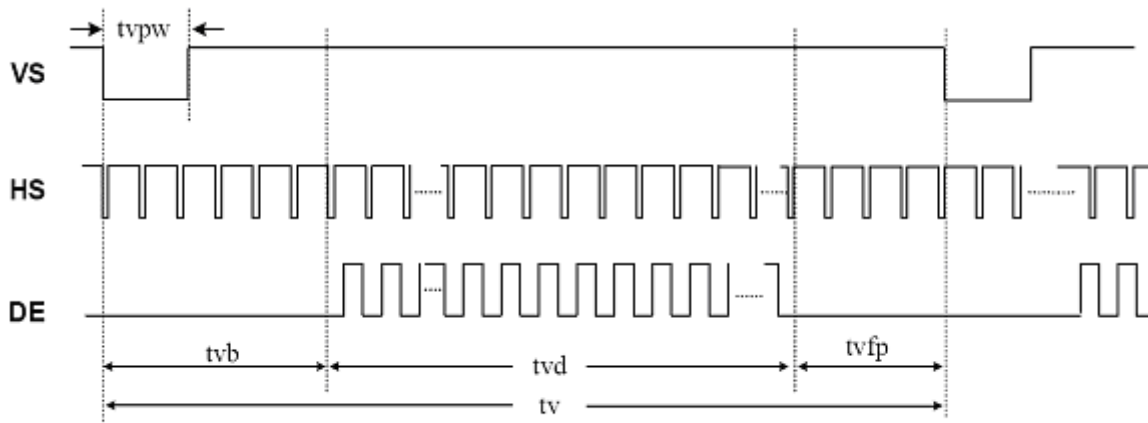



TCON Horizontal Input Timing Diagram

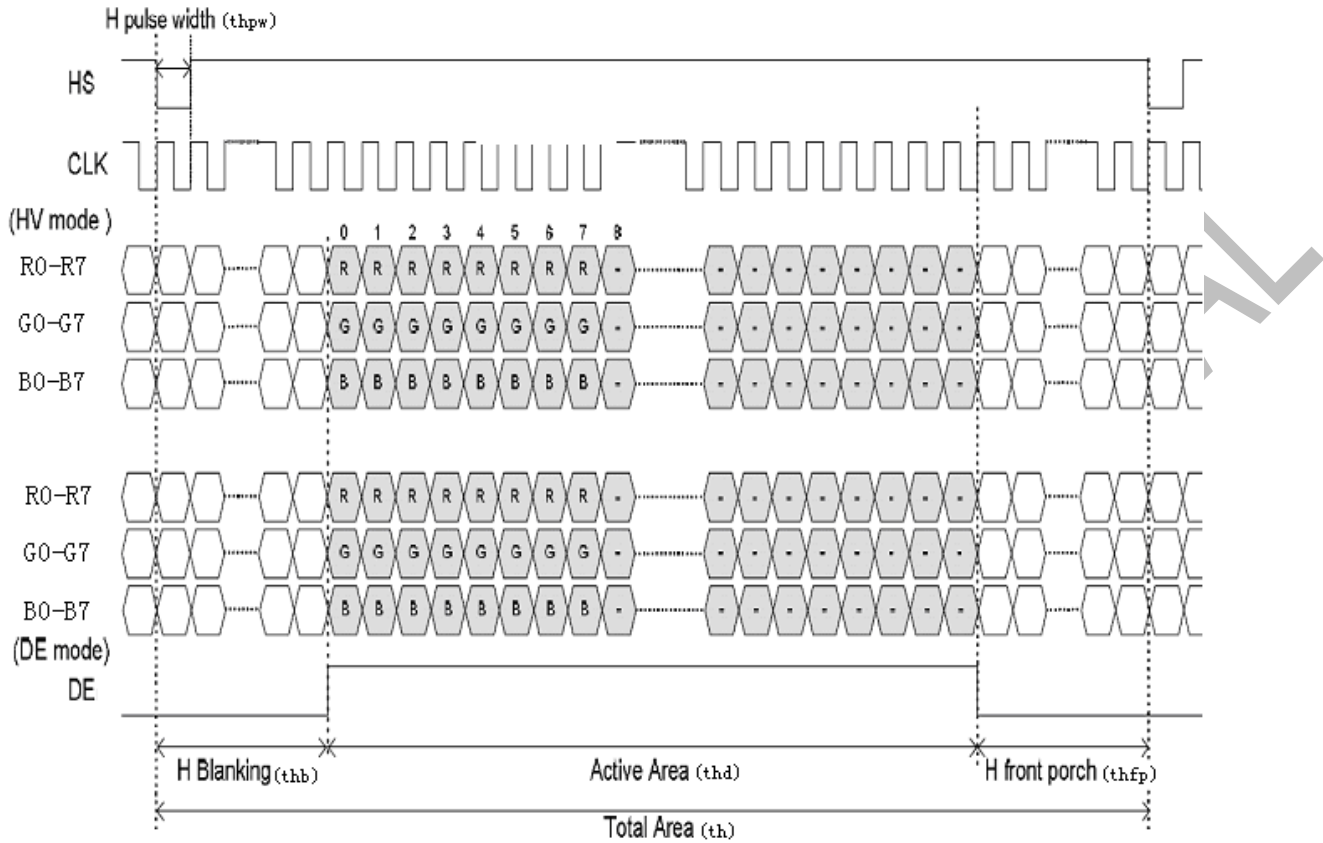

5.3 POWER ON/OFF SEQUENCE

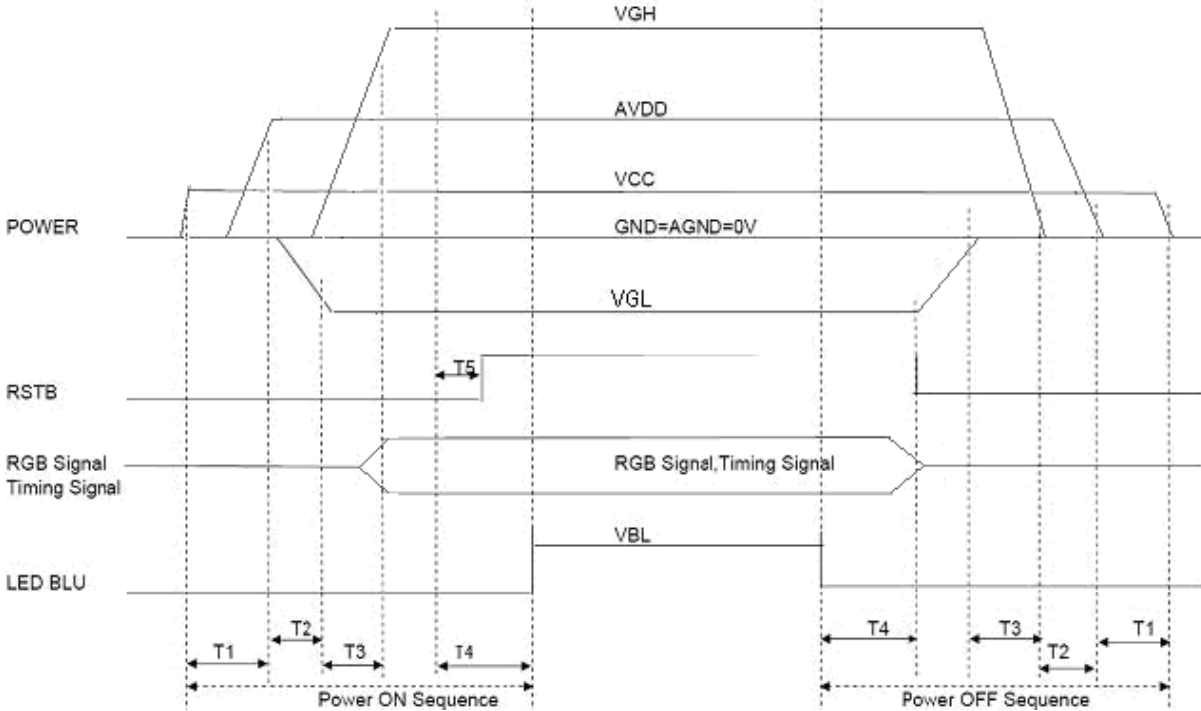

Note 1: $T_1 \geq 20ms$, $T_2 \geq 20ms$, $T_3 \geq 5ms$, $T_4 \geq 100ms$, $T_5 \geq 5ms$.



6 Optical Characteristics

Ta=25°C

Item	Symbol	Condition	Min	Typ	Max	Unit	Remark
View Angles	θT	$CR \geq 10$	50	60	-	Degree	Note 2
	θB		60	70	-		
	θL		60	70	-		
	θR		60	70	-		
Contrast Ratio	CR	$\theta=0^\circ$	400	500	-		Note1 Note3
Response Time	T_{ON}	25°C	-	25	-	ms	Note1 Note4
	T_{OFF}						
Chromaticity	White	x	Backlight is on	0.265	0.315	0.365	Note1 Note5
		y		0.280	0.330	0.380	
	Red	x		0.541	0.591	0.641	
		y		0.300	0.350	0.400	
	Green	x		0.298	0.348	0.298	
		y		0.521	0.571	0.621	
	Blue	x		0.101	0.151	0.201	
		y		0.051	0.101	0.151	
Uniformity	U		-	75	-	%	Note1 Note6
NTSC			-	50	-	%	Note 5
Luminance (Without TP)	L		280	350	-	cd/m ²	Note1 Note7

Test Conditions:

1. $I_F=160\text{ mA}$, $V_F=9.6\text{ V}$ and the ambient temperature is $25\pm 2^\circ\text{C}$. humidity is $65\pm 7\%$
2. The test systems refer to Note 1 and Note 2.



Note 1: Definition of optical measurement system.

The optical characteristics should be measured in dark room. After 5 Minutes operation, the optical properties are measured at the center point of the LCD screen. All input terminals LCD panel must be ground when measuring the center area of the panel.

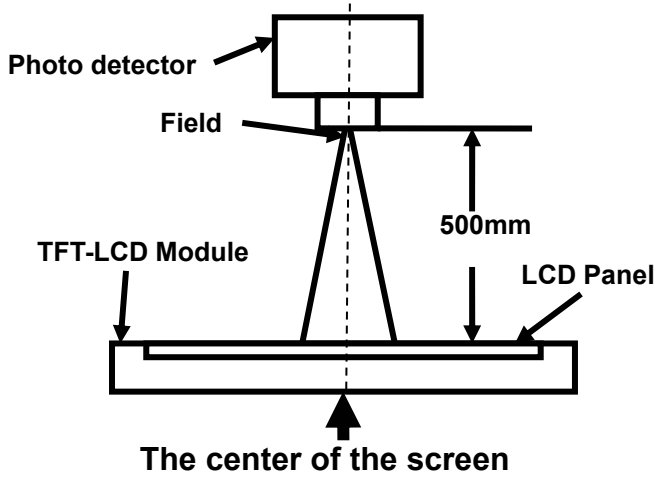

Item	Photo detector	Field
Contrast Ratio	SR-3A	1°
Luminance		
Chromaticity		
Lum Uniformity	BM-7A	2°
Response Time		

Note 2: Definition of viewing angle range and measurement system.

viewing angle is measured at the center point of the LCD by CONOSCOPE(ergo-80).

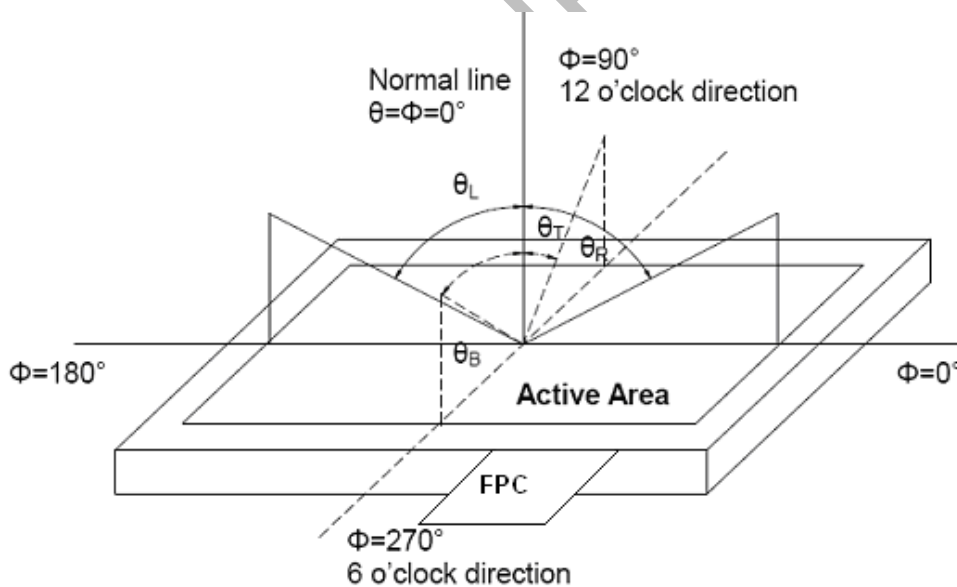

Note 3: Definition of contrast ratio

$$\text{Contrast ratio (CR)} = \frac{\text{Luminance measured when LCD is on the "White" state}}{\text{Luminance measured when LCD is on the "Black" state}}$$

“White state “: The state is that the LCD should drive by V_{white} .

“Black state”: The state is that the LCD should drive by V_{black} .

V_{white} : To be determined V_{black} : To be determined.

Note 4: Definition of Response time

The information contained herein is the exclusive property of SHANGHAI AVIC OPTOELECTRONICS Corporation, and shall not be distributed, reproduced, or disclosed in whole or in part without prior written permission of SHANGHAI AVIC OPTOELECTRONICS Corporation.



The response time is defined as the LCD optical switching time interval between "White" state and "Black" state. Rise time (T_{ON}) is the time between photo detector output intensity changed from 90% to 10%. And fall time (T_{OFF}) is the time between photo detector output intensity changed from 10% to 90%.

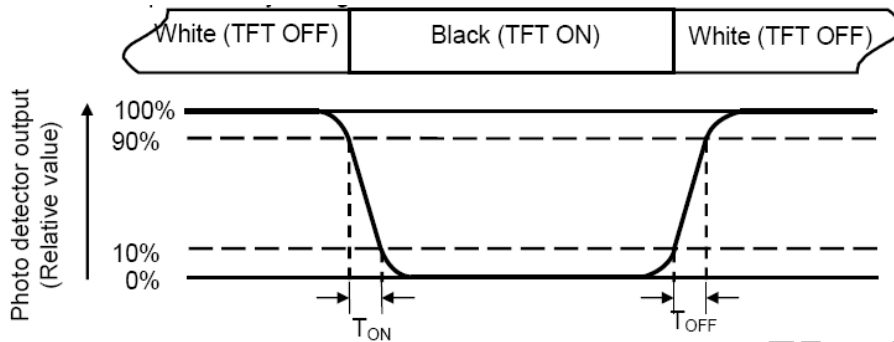

Note 5: Definition of color chromaticity (CIE1931)

Color coordinates measured at center point of LCD.

Note 6: Definition of Luminance Uniformity

Active area is divided into 9 measuring areas (Refer Fig. 2). Every measuring point is placed at the center of each measuring area.

Luminance Uniformity (U) = L_{min} / L_{max}

L-----Active area length W----- Active area width

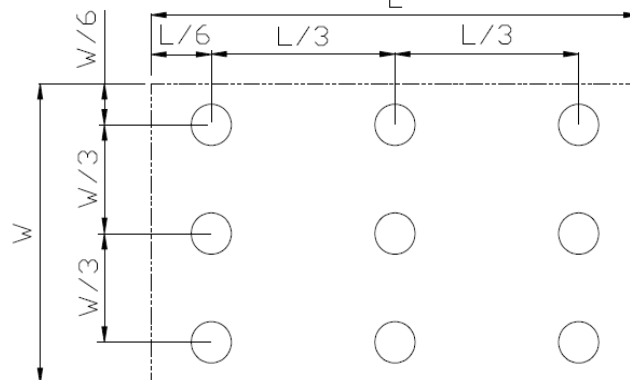

L_{max} : The measured Maximum luminance of all measurement position.

L_{min} : The measured Minimum luminance of all measurement position.

Note 7: Definition of Luminance:

Measure the luminance of white state at center point.



7 Environmental / Reliability Test

No	Test Item	Condition	Remarks
1	High Temperature Operation	Ts = +70°C, 240 hours	IEC60068-2-1 GB2423.2
2	Low Temperature Operation	Ta = -20°C, 240 hours	IEC60068-2-1 GB2423.1
3	High Temperature Storage	Ta = +80°C, 240 hours	IEC60068-2-1 GB2423.2
4	Low Temperature Storage	Ta = -30°C, 240 hours	IEC60068-2-1 GB2423.1
5	Storage at High Temperature and Humidity	Ta = +60°C, 90% RH max,240hours	IEC60068-2-78 GB/T2423.3
6	Thermal Shock (non-operation)	-30°C 30 min~+80°C 30 min, Change time:5min, 100 Cycle	Start with cold temperature, End with high temperature, IEC60068-2-14,GB2423.22
7	ESD	C=150pF,R=330Ω,5point/panel Air:±8Kv,5times; Contact:±4Kv,5times (Environment:15°C~35°C, 30%~60%.86Kpa~106Kpa)	IEC61000-4-2 GB/T17626.2
8	Vibration Test	Frequency range:10~55Hz Stroke:1.5mm Sweep:10Hz~55Hz~10Hz 2 hours for each direction of X.Y.Z. (6 hours for total)	IEC60068-2-6 GB/T2423.10
9	Mechanical Shock (Non Op)	Half Sine Wave 100G 6ms, ±X,±Y,±Z 3times for each direction	IEC60068-2-27 GB/T2423.5
10	Package Drop Test	Height:60cm, 1corner,3edges,6surfaces	IEC60068-2-32 GB/T2423.8

Note1: Ts is the temperature of panel's surface.

Note2: Ta is the ambient temperature of samples.



9 Packing drawing

No	Item	Model (Material)	Dimensions(mm)	Unit Weight(Kg)	Quantity	Remark
1	LCM module	TM070RDH10	164.90x100.00x5.7	TBD	50	
2	Partition_1	Corrugated Paper	513x333x215	2.0	1	
3.	Anti-Static Bag	PE	200x175x0.05	0.01	50	Anti-static
4	Dust-Proof Bag	PE	700x545	0.0600	1	
5	Partition_2	Corrugated Paper	505x332	0.1	2	
6	Corrugated Bar	Corrugated Paper	513x148	0.06	4	
7	Beauty-grain	Tape	30x10	TBD	50	
8	Dessicant	Dessicant	45x35	0.002	8	
9	Carton	Corrugated Paper	530x350x250	1.1000	1	
10	Total weight	TBD±5%				

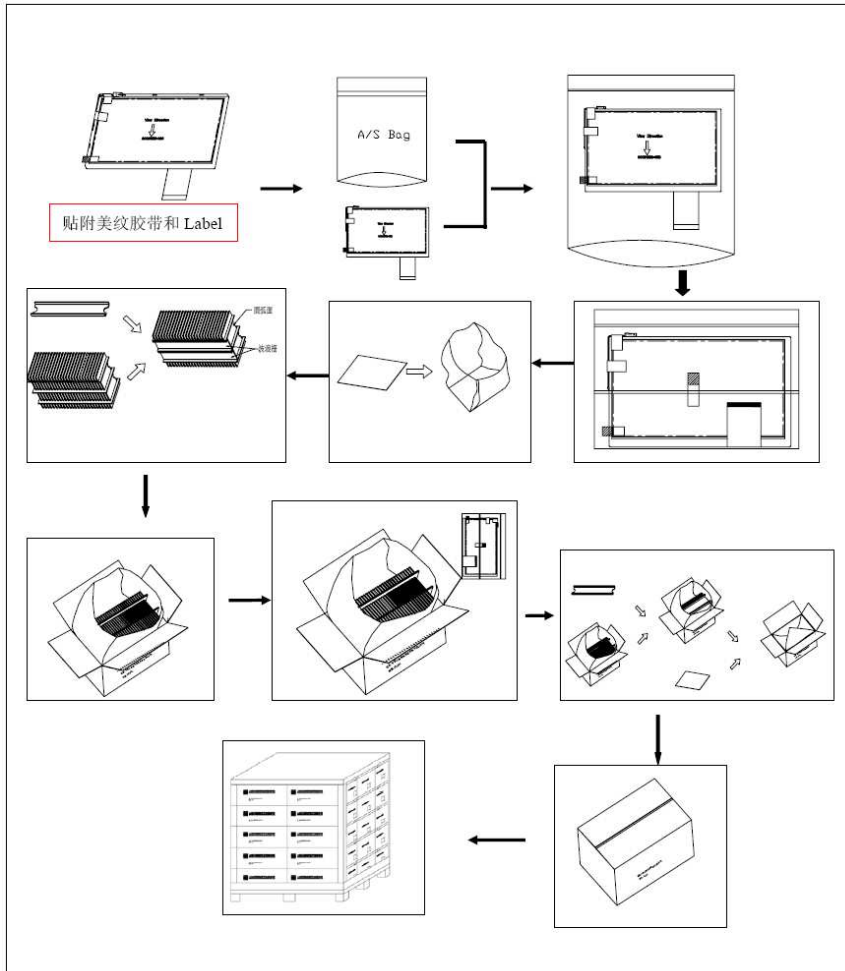



10 Precautions for Use of LCD Modules

10.1 Handling Precautions

10.1.1 The display panel is made of glass. Do not subject it to a mechanical shock by dropping it from a high place, etc.

10.1.2 If the display panel is damaged and the liquid crystal substance inside it leaks out, be sure not to get any in your mouth, if the substance comes into contact with your skin or clothes, promptly wash it off using soap and water.

10.1.3 Do not apply excessive force to the display surface or the adjoining areas since this may cause the color tone to vary.

10.1.4 The polarizer covering the display surface of the LCD module is soft and easily scratched. Handle this polarizer carefully.

10.1.5 If the display surface is contaminated, breathe on the surface and gently wipe it with a soft dry cloth. If still not completely clear, moisten cloth with one of the following solvents:

- Isopropyl alcohol
- Ethyl alcohol

Solvents other than those mentioned above may damage the polarizer. Especially, do not use the following:

- Water
- Ketone
- Aromatic solvents

10.1.6 Do not attempt to disassemble the LCD Module.

10.1.7 If the logic circuit power is off, do not apply the input signals.

10.1.8 To prevent destruction of the elements by static electricity, be careful to maintain an optimum work environment.

10.1.8.1 Be sure to ground the body when handling the LCD Modules.

10.1.8.2 Tools required for assembly, such as soldering irons, must be properly ground.

10.1.8.3 To reduce the amount of static electricity generated, do not conduct assembly and other work under dry conditions.

10.1.8.4 The LCD Module is coated with a film to protect the display surface. Be care when peeling off this protective film since static electricity may be generated.

10.2 Storage precautions

10.2.1 When storing the LCD modules, avoid exposure to direct sunlight or to the light of fluorescent lamps.

10.2.2 The LCD modules should be stored under the storage temperature range. If the LCD modules will be stored for a long time, the recommend condition is:

Temperature : 0°C ~ 40°C Relatively humidity: ≤80%

10.2.3 The LCD modules should be stored in the room without acid, alkali and harmful gas.

10.3 Transportation Precautions

10.3.1 The LCD modules should be no falling and violent shocking during transportation, and also should avoid excessive press, water, damp and sunshine.