



MODEL NO. : TM070RDH01ISSUED DATE: 2009-12-16VERSION : Ver 2.2

- Preliminary Specification
 Final Product Specification

Customer : _____

Approved by	Notes

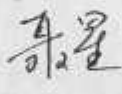
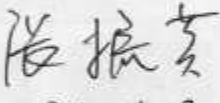
SHANGHAI TIANMA Confirmed :

Prepared by	Checked by	Approved by
 2010.1.13	 2010-01-13	

This technical specification is subjected to change without notice

The information contained herein is the exclusive property of SHANGHAI TIANMA MICRO-ELECTRONICS Corporation, and shall not be distributed, reproduced, or disclosed in whole or in part without prior written permission of SHANGHAI TIANMA MICRO-ELECTRONICS Corporation.



Table of Contents

Coversheet	1
Table of Contents.....	2
Record of Revision	3
1 General Specifications	4
2 Input/Output Terminals.....	5
3 Absolute Maximum Ratings	8
4 Electrical Characteristics	9
5 Timing Chart	14
6 Optical Characteristics.....	20
7 Environmental / Reliability Test.....	23
8 Mechanical Drawing	24
9 Packing Drawing.....	25
10 Precautions for Use of LCD Modules	27

TIANMA CONFIDENTIAL



1 General Specifications

Feature		Spec
Display Spec.	Size	6.95 inch
	Resolution	800(RGB) x 480
	Interface	RGB 18 bits without TCON
	Color Depth	262K
	Technology Type	a-Si
	Pixel Pitch (mm)	0.1965x0.1715
	Pixel Configuration	R.G.B. Vertical Stripe
	Display Mode	TM with Normally White
	Surface Treatment(Up Polarizer)	Anti Glare
	Viewing Direction	12 o'clock
	Gray Scale Inversion Direction	6 o'clock
Mechanical Characteristics	LCM (W x H x D) (mm)	167.00x93.00x5.40
	Active Area(mm)	157.20x82.32
	With /Without TSP	Without TSP
	Weight (g)	138.4
	LED Numbers	30 LEDs

Note 1: Viewing direction for best image quality is different from TFT definition; there is a 180 degree shift.

Note 2: Requirements on Environmental Protection: Q/S0002

Note 3: LCM weight tolerance : +/- 5%



2 Input/Output Terminals

TFT-LCD Panel Driving

Matching connector of FH12S-30S-0.5SH

CN1 of FPC2

Pin	Symbol	I/O	Description	Remark
1	DIO1	I/O	Horizontal start pulse signal	Note1,2
2	VSS1	P	Ground	Note1
3	VDD1	P	Power supply	
4	CLK	I	Horizontal shift clock	
5	VSS1	P	Ground	
6	R/L	I	Right/left selection	Note2
7	R0	I	Red data(LSB)	
8	R1	I	Red data	
9	R2	I	Red data	
10	R3	I	Red data	
11	R4	I	Red data	
12	R5	I	Red data	
13	VSS1	P	Ground	
14	G0	I	Green data(LSB)	
15	G1	I	Green data	
16	G2	I	Green data	
17	G3	I	Green data	
18	G4	I	Green data	
19	G5	I	Green data	
20	VSS1	P	Ground	
21	B0	I	Blue data(LSB)	
22	B1	I	Blue data	
23	B2	I	Blue data	
24	B3	I	Blue data	
25	B4	I	Blue data	
26	B5	I	Blue data	
27	LD	I	Load output signal	

The information contained herein is the exclusive property of SHANGHAI TIANMA MICRO-ELECTRONICS Corporation, and shall not be distributed, reproduced, or disclosed in whole or in part without prior written permission of SHANGHAI TIANMA MICRO-ELECTRONICS Corporation.



28	REV	I	Data invert control	
29	POL	I	Polarity selection	
30	DIO2	I/O	Horizontal start pulse signal	Note2

CN2 of FPC2

Pin	Symbol	I/O	Description	Remark
1	VSS2	P	Ground	
2	V1	I	Gamma voltage 1	
3	V2	I	Gamma voltage 2	
4	V3	I	Gamma voltage 3	
5	V4	I	Gamma voltage 4	
6	V5	I	Gamma voltage 5	
7	V6	I	Gamma voltage 6	
8	V7	I	Gamma voltage 7	
9	VSS2	P	Ground	
10	V8	I	Gamma voltage 8	
11	V9	I	Gamma voltage 9	
12	V10	I	Gamma voltage 10	
13	V11	I	Gamma voltage 11	
14	V12	I	Gamma voltage 12	
15	V13	I	Gamma voltage 13	
16	V14	I	Gamma voltage 14	
17	VSS2	P	Ground	
18	VDD2	P	Voltage for analog circuit	
19	VCOM	I	Common voltage	
20	XON	N	NC	
21	OE	I	Output enable	
22	U/D	I	Up/down selection	Note2
23	CKV	I	Vertical shift clock	
24	STVU	I/O	Vertical shift pulse signal	Note2
25	STVD	I/O	Vertical shift pulse signal	Note2
26	VGG	P	Gate on voltage	
27	GND	P	Ground	

The information contained herein is the exclusive property of SHANGHAI TIANMA MICRO-ELECTRONICS Corporation, and shall not be distributed, reproduced, or disclosed in whole or in part without prior written permission of SHANGHAI TIANMA MICRO-ELECTRONICS Corporation.



28	VCC	P	Voltage for logic circuit	
29	GND	P	Ground	
30	VEE	P	Gate off voltage	

Note1: I/O definition.

I---Input, O---Output, P--- Power/Ground, N--- No connection

Note2:

Scan Control Input		IN/OUT State For Start Pulse				Scanning Direction
U/D	R/L	STVD	STVU	DIO2	DIO1	
GND	VCC	O	I	O	I	Down to up, Left to right
VCC	GND	I	O	I	O	Up to down, Right to left
GND	GND	O	I	I	O	Down to up, Right to left
VCC	VCC	I	O	O	I	Up to down, Left to right



3 Absolute Maximum Ratings

VSS1=VSS2=GND=0V, Ta = 25°C

Item	Symbol	Min	Max	Unit	Remark
Power Voltage	VDD1	-0.50	5.00	V	
	VDD2	-0.50	13.50	V	
	VGG	-0.30	40.00	V	
	VEE	-20.00	0.30	V	
	VGG-VEE	-0.30	40.00	V	
Backlight Forward Current	I _{LED}	-	25.00	mA	For each LED
Operating Temperature	T _{OPR}	-20	70	°C	
Storage Temperature	T _{STG}	-30	80	°C	



4 Electrical Characteristics

4.1 Recommended Operating Condition

VSS1=VSS2=GND=0V, Ta = 25°C

Item		Symbol	Min	Typ	Max	Unit	Remark
Digital Supply Voltage		VDD1	3.00	3.30	3.60	V	
Digital Supply Voltage		VCC	3.00	3.30	3.60	V	
Analog Supply Voltage		VDD2	9.45	9.84	10.23	V	Note1
Gate On Voltage		VGG	17.10	19.00	20.90	V	Note1
Gate Off Voltage		VEE	-7.70	-7.00	-6.30	V	Note1
Common Electrode Driving Signal		VCOM	-	4.21	-	V	Note1
Input Level Of Gamma Voltage		V1~V7	0.4xAVDD	-	VDD2-0.1	V	
		V8~V14	0.1	-	0.6xVDD2	V	
Input Signal Voltage	Low Level	V _{IL}	0	-	0.2xVDD1	V	CLK,R/L,R0~R5,G0~G5, B0~B5,LD,REV,POL, V1~V14,OE,U/D,CKV, DIO1/2,STVU,STVD
	High Level	V _{IH}	0.8xVDD1	-	VDD1	V	
Output Signal Voltage	Low Level	V _{OL}	VSS1	-	0.3xVDD1	V	DIO1/2,STVU,STVD
	High Level	V _{OH}	0.7xVDD1	-	VDD1	V	



4.2 Gamma Correction Reference Voltage Setting

VDD2=9.840V, VCOM=4.210V, VSS1=VSS2=GND=0V, Ta = 25°C

Parameter	Symbol	Min	Typ	Max	Unit	Remark
Gamma Correction Reference Voltage (V1~V14)	V1	-	9.640	VDD2-0.1	V	
	V2	-	9.400	-	V	
	V3	-	7.830	-	V	
	V4	-	7.230	-	V	
	V5	-	6.840	-	V	
	V6	-	6.200	-	V	
	V7	-	5.010	-	V	
	V8	-	4.810	-	V	
	V9	-	3.627	-	V	
	V10	-	2.987	-	V	
	V11	-	2.598	-	V	
	V12	-	1.997	-	V	
	V13	-	0.438	-	V	
	V14	VSS2+0.1	0.198	-	V	

Note: Need to simultaneously consider the effect of internal resistor in source driver and external resistor on TCON board, when setting gamma reference voltage.

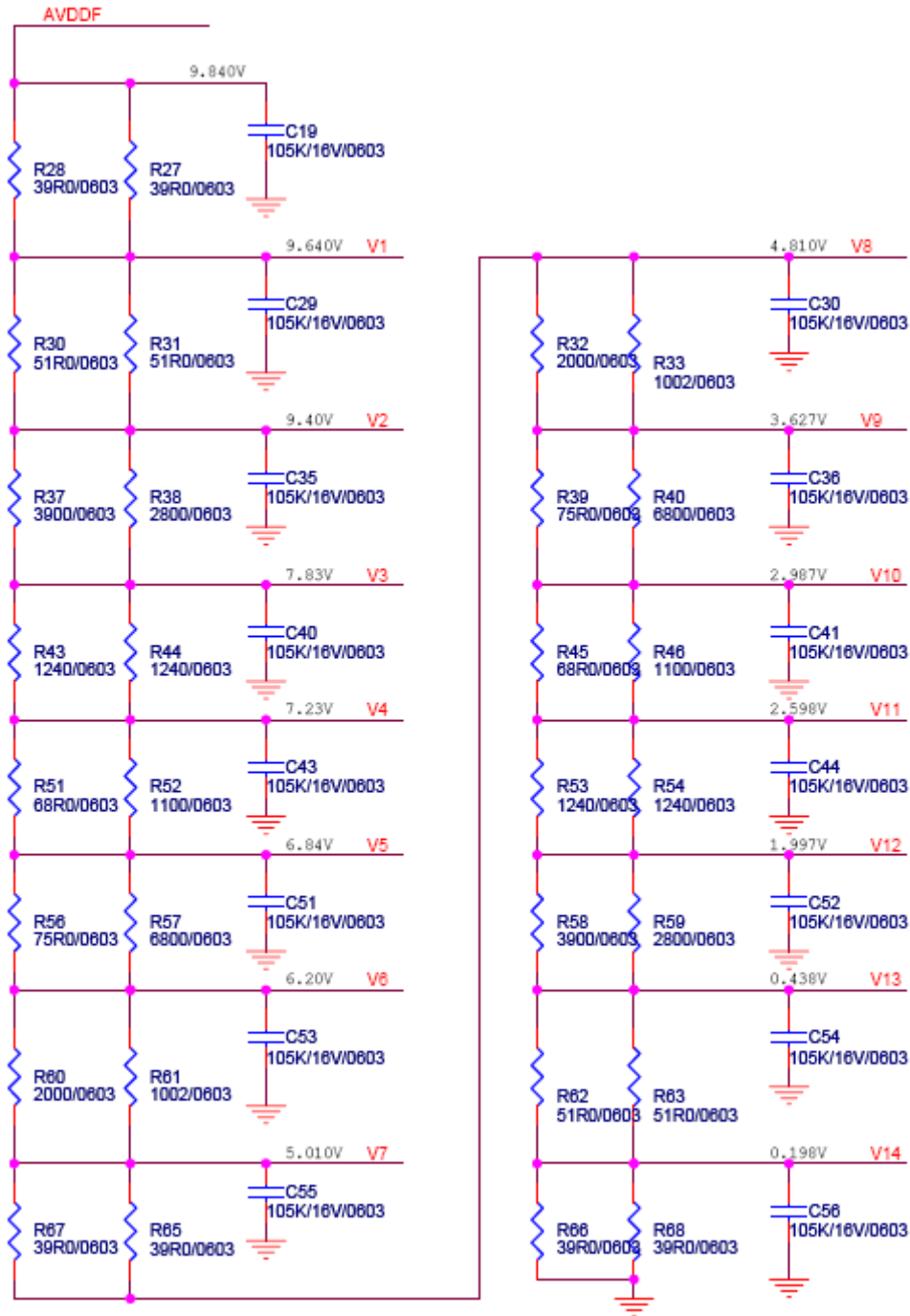

NOTE : The gamma circuit only apply to AVDD=9.840V,Connect LCM to the gamma circuit and keep LCM operation, you can get correct gamma voltage, V1=9.64V 、V2=9.40V etc.



4.3 Recommended Driving Condition for Backlight

Ta=25°C

Item	Symbol	Min	Typ	Max	Unit	Remark
Forward Current	I_{LED}	-	20.00	25.00	mA	Note 1,2,3
Forward Current Voltage	V_{LED}	-	9.60	10.20	V	
Backlight Power Consumption	W_{BL}	-	1.92	2.55	W	
Operating Life Time	--	10000	(20000)	--	hrs	Note 4

BLU connector:

Pin	Symbol	I/O	Description	Remark
1	LED+	P	LED anode	Note 5
2	LED-	P	LED cathode	Note 5

Note 1: The LED driving condition is defined for each LED module (3 LED Serial) .

$$\text{Input current} = 20 \text{ mA} \times 10 = 200 \text{ mA}$$

Note 2: $W_{BL} = I_{LED1} \times V_{LED1} + I_{LED2} \times V_{LED2} \dots \dots + I_{LED29} \times V_{LED29} + I_{LED30} \times V_{LED30}$

Note 3: The LED driving condition is defined for each LED module.

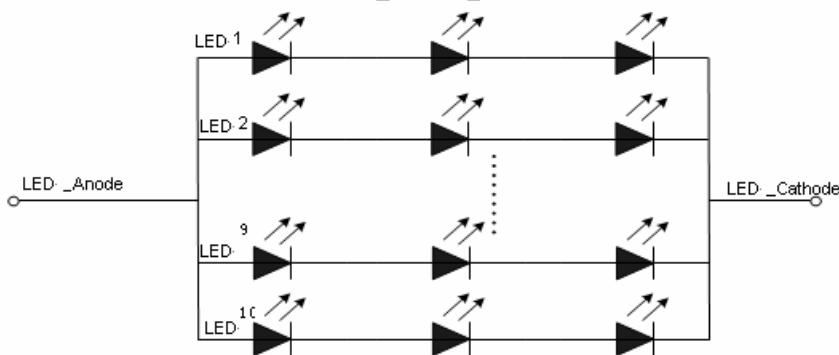

Note 4: I_F is defined for one channel LED.

Optical performance should be evaluated at Ta=25°C only.

If LED is driven by high current, high ambient temperature & humidity condition.

The life time of LED will be reduced.

Operating life means brightness goes down to 50% initial brightness.

Typical operating life time is estimated data.

Note 5: Under LCM operating, the stable forward current should be inputted.



4.4 Power Consumption

VSS1=VSS2=GND=0V, Ta = 25°C

Item	Symbol	Condition	Min	Typ	Max	Unit	Remark
Digital Supply Current	IDD1	VDD1=3.3V	-	3.50	5.16	mA	
Digital Supply Current	ICC	VCC=3.3V	-	3.50	5.16	mA	
Analog Supply Current	IDD2	VDD2=9.84V	-	28.00	40.00	mA	
Gate On Current	IGG	VGG=19.0V	-	0.22	0.40	mA	
Gate Off Current	IEE	VEE=-7.0V	-	0.22	0.40	mA	
Power Consumption	Panel		-	0.30	0.42	W	
	Backlight		-	1.92	2.55	W	
	Total		-	2.22	2.97	W	

Note: The power consumption condition is defined as colorbar pattern.

4.5 Block Diagram

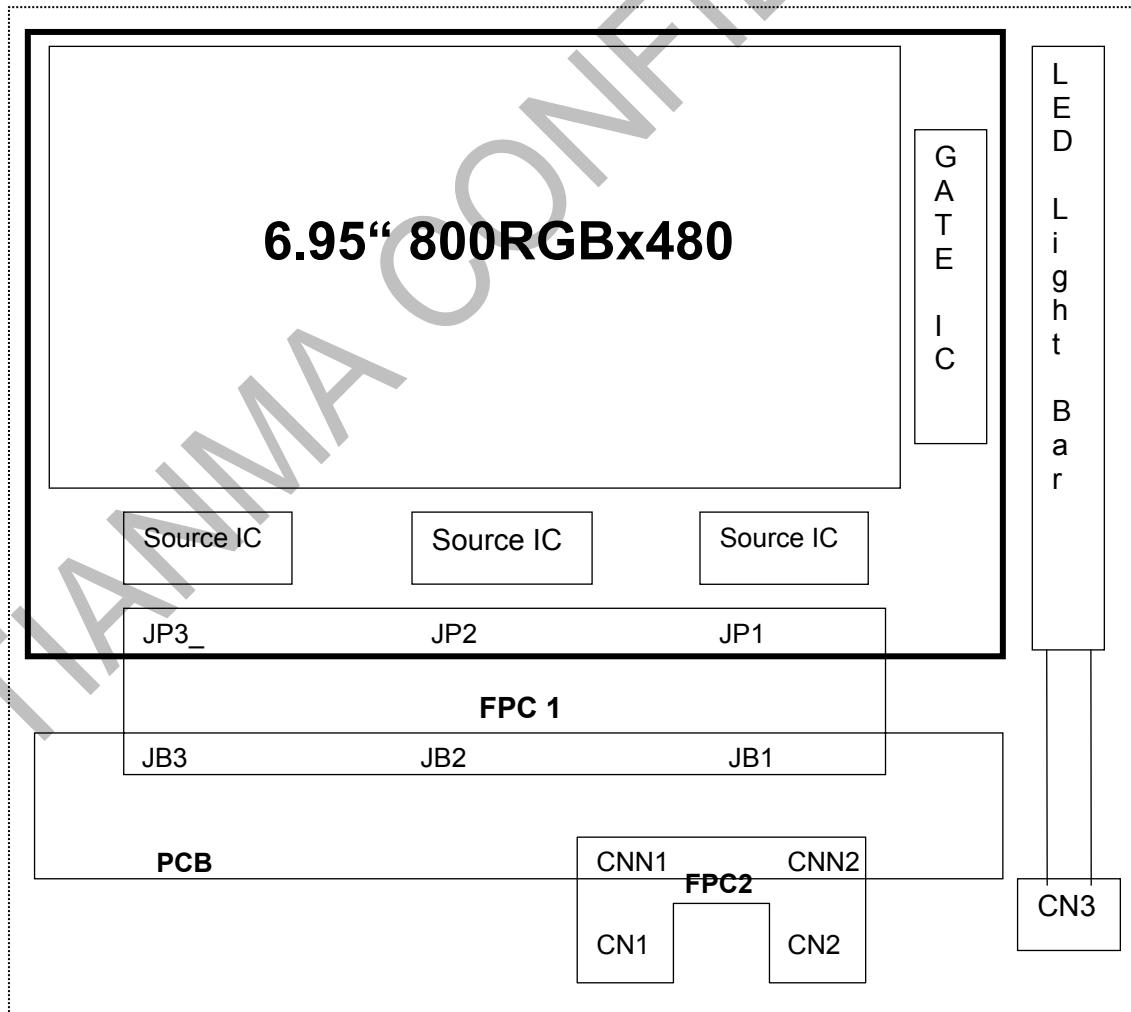

The information contained herein is the exclusive property of SHANGHAI TIANMA MICRO-ELECTRONICS Corporation, and shall not be distributed, reproduced, or disclosed in whole or in part without prior written permission of SHANGHAI TIANMA MICRO-ELECTRONICS Corporation.



5 Timing Chart

5.1 Source Driver Input Timing

(VCC=3.3V, VDD2=9.84V, VSS1=VSS2=GND=0V, Ta=25°C)

Parameter	Symbol	Min	Typ	Max	Unit	Conditions
CLK Frequency	Fclk	-	33.3	40.0	MHz	EDGSL="0"
CLK Pulse Width	Tcw	40%	-	60%	Tcph	Tcph is CLK cycle
Data Set-up Time	Tsu	4	-	-	ns	DIO1/2 to CLK
Data Hold Time	Thd	2	-	-	ns	DIO1/2 to CLK
Propagation Delay Of DIO1/2	Tphl	5	10	15	ns	CL=25pF
Time That The Last Data To LD	Tld	1	-	-	Tcph	
Pulse Width Of LD	Twld	2	-	-	Tcph	
Time That LD To DIO1/2	Tlds	5	-	-	Tcph	
POL Set-up Time	Tpsu	6	-	-	ns	POL to LD
POL Hold Time	Tphd	6	-	-	ns	POL to LD
Output Stable Time	Tst	-	-	9	us	10% or 90% target voltage. CL=60pF, R=2Kohm



5.1.1 EDGSL='0', Source Driver Input Timing

<< EDGSL= "0", Default >>

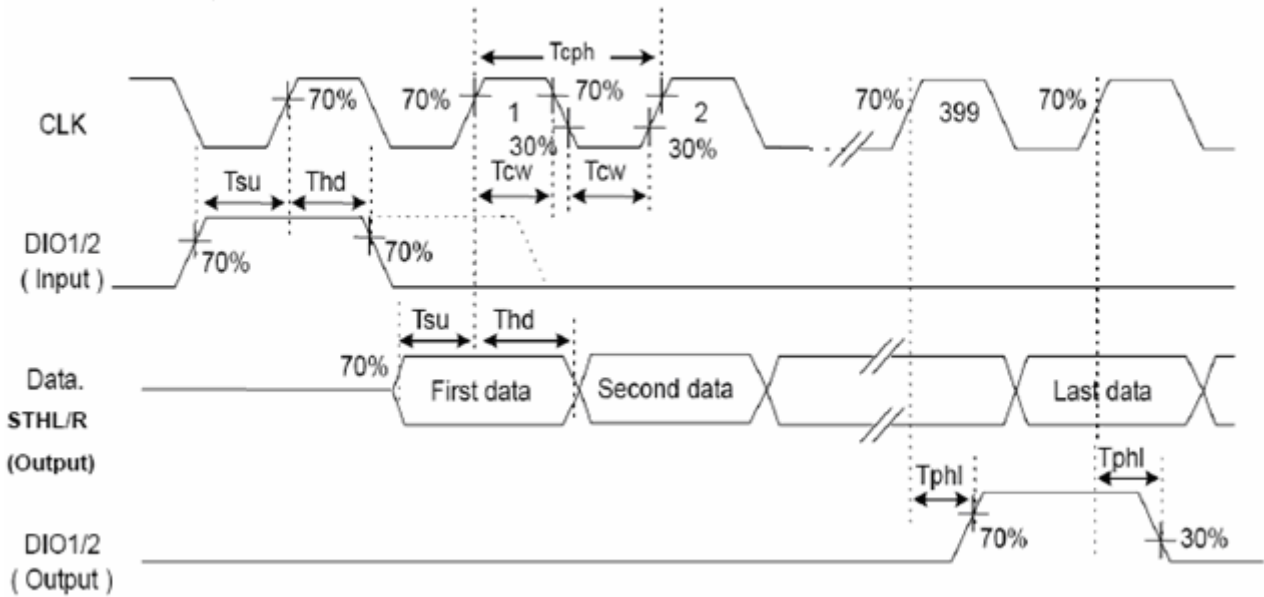

5.1.2 Source Driver Input Timing

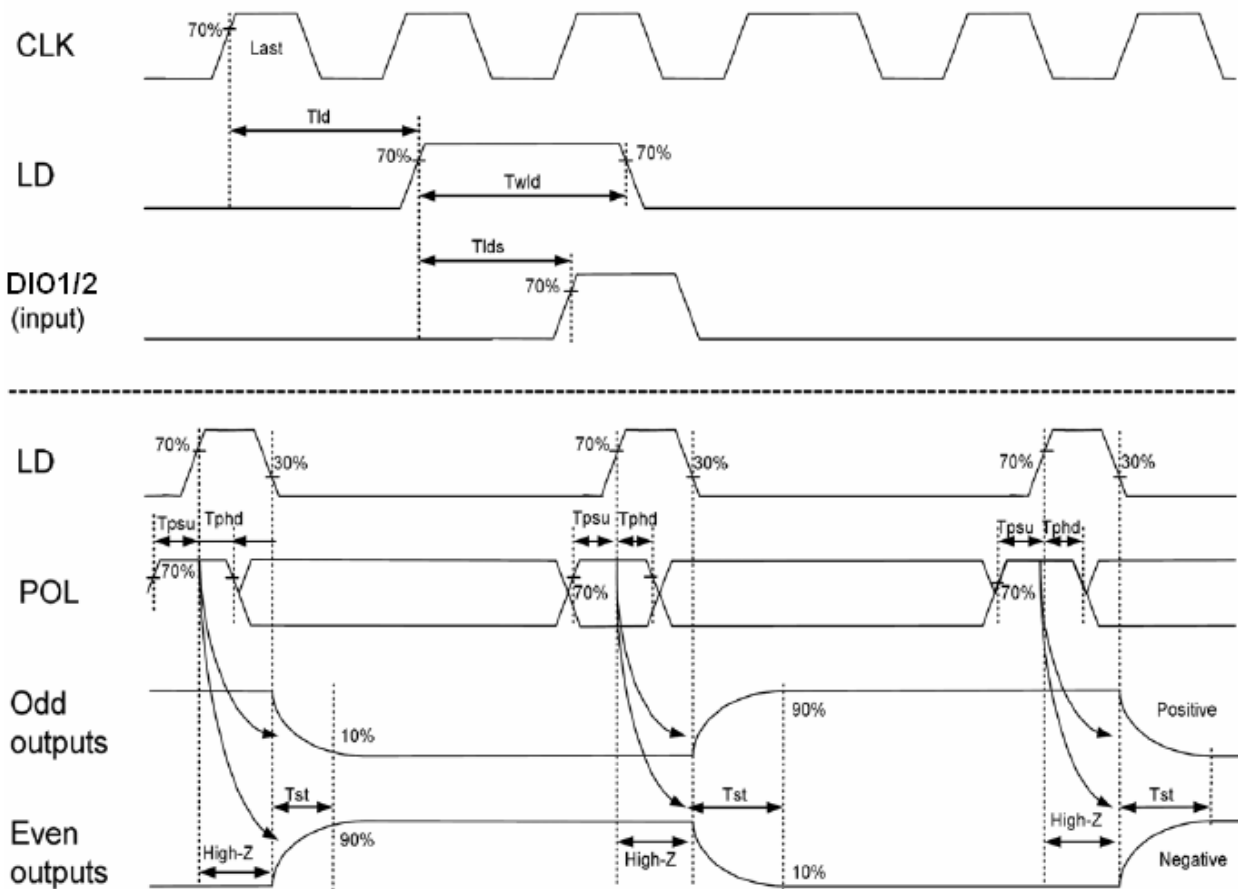

The information contained herein is the exclusive property of SHANGHAI TIANMA MICRO-ELECTRONICS Corporation, and shall not be distributed, reproduced, or disclosed in whole or in part without prior written permission of SHANGHAI TIANMA MICRO-ELECTRONICS Corporation.



5.2 Gate Driver Input Timing

(VGG=19V, VEE=-7V, VDD1=3.3V, VSS1=GND=0V, Ta=25°C)

Parameter	Symbol	Min	Typ	Max	Unit	Conditions
STVD/STVU Delay Time	Tdt	-	-	500	ns	CL=20pF
Driver Output Delay Time	Tdo	-	-	900	ns	CL=200pF
Output Falling Time	Tthl	-	400	800	ns	CL=200pF 90% to 10%
Output Rising Time	Ttlh	-	500	1000	ns	CL=200pF 10% to 90%
XON To Driver Output Delay Time	Txon	-	-	20	ns	CL=200pF
OE To Driver Output Delay Time	Toe	-	-	900	ns	CL=200pF
Clock Frequency	Fclk	-	-	200	KHz	In cascade connection
Clock Rising Time	Trck	-	-	100	ns	CL=20pF
Clock Falling Time	Tfck	-	-	100	ns	CL=20pF
Clock Pulse Width(High & Low)	PWCLK	500	-	-	ns	
STVD/STVU Set-up Time	Tsu	200	-	-	ns	
STVD/STVU Hold Time	Thd	300	-	-	ns	
Output Enable Pulse Width	Twcl	1	-	-	us	1

5.2.1 Gate Driver Input Timing

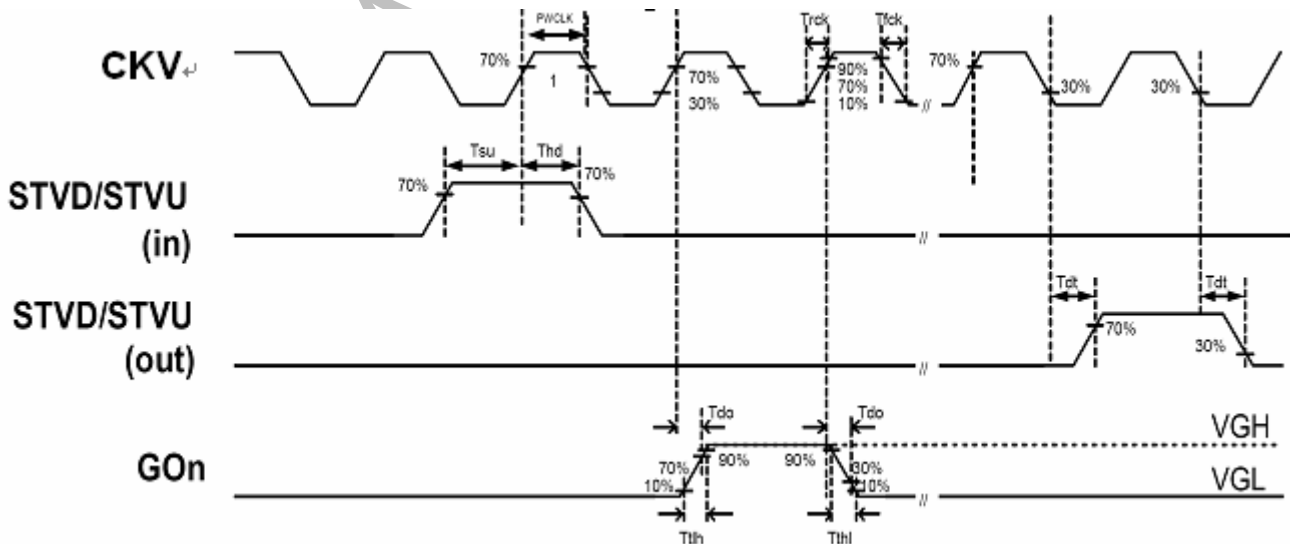

The information contained herein is the exclusive property of SHANGHAI TIANMA MICRO-ELECTRONICS Corporation, and shall not be distributed, reproduced, or disclosed in whole or in part without prior written permission of SHANGHAI TIANMA MICRO-ELECTRONICS Corporation.



5.3 Recommended Timing Setting Of TCON At HV Mode

5.3.1 DCLK/ HSYNC/VSYNC Timing

Parameter	Symbol	Min	Typ	Max	Unit	Remark
DCLK	Fclk	26.4	33.3	40.0	MHZ	
	Tclk	37.9	30.0	25.0	ns	
HSYNC	t_h	862	1056	1200	Tclk	
	t_{hd}	800	800	800	Tclk	
	t_{hpw}	1	-	40	Tclk	
	t_{hb}	46	46	46	Tclk	
	t_{hfp}	16	210	354	Tclk	
VSYNC	t_v	510	525	650	th	
	t_{vd}	480	480	480	th	
	t_{vpw}	1	-	20	th	
	t_{vb}	23	23	23	th	
	t_{vfp}	7	22	147	th	

Note: Base on TCON NT39703-5



5.3.2 Vertical Input Timing

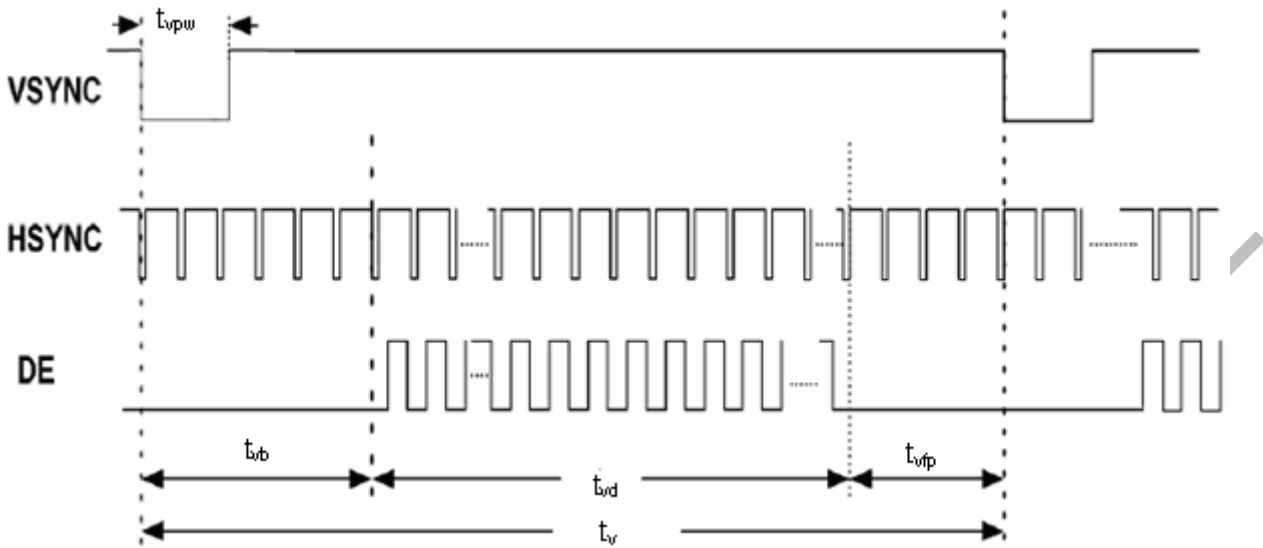

5.3.3 Horizontal Input Timing

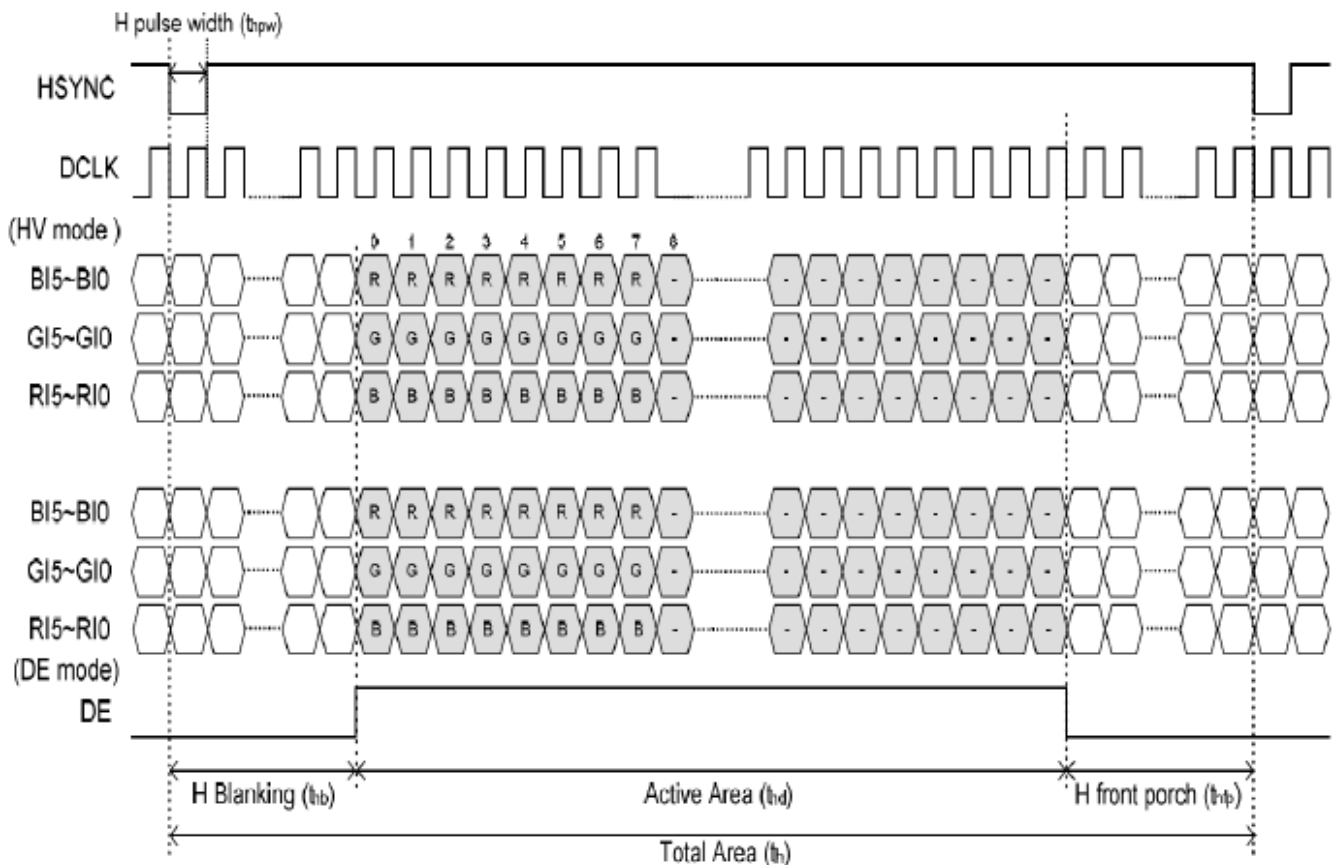

The information contained herein is the exclusive property of SHANGHAI TIANMA MICRO-ELECTRONICS Corporation, and shall not be distributed, reproduced, or disclosed in whole or in part without prior written permission of SHANGHAI TIANMA MICRO-ELECTRONICS Corporation.



5.4 Power On/Off Sequence

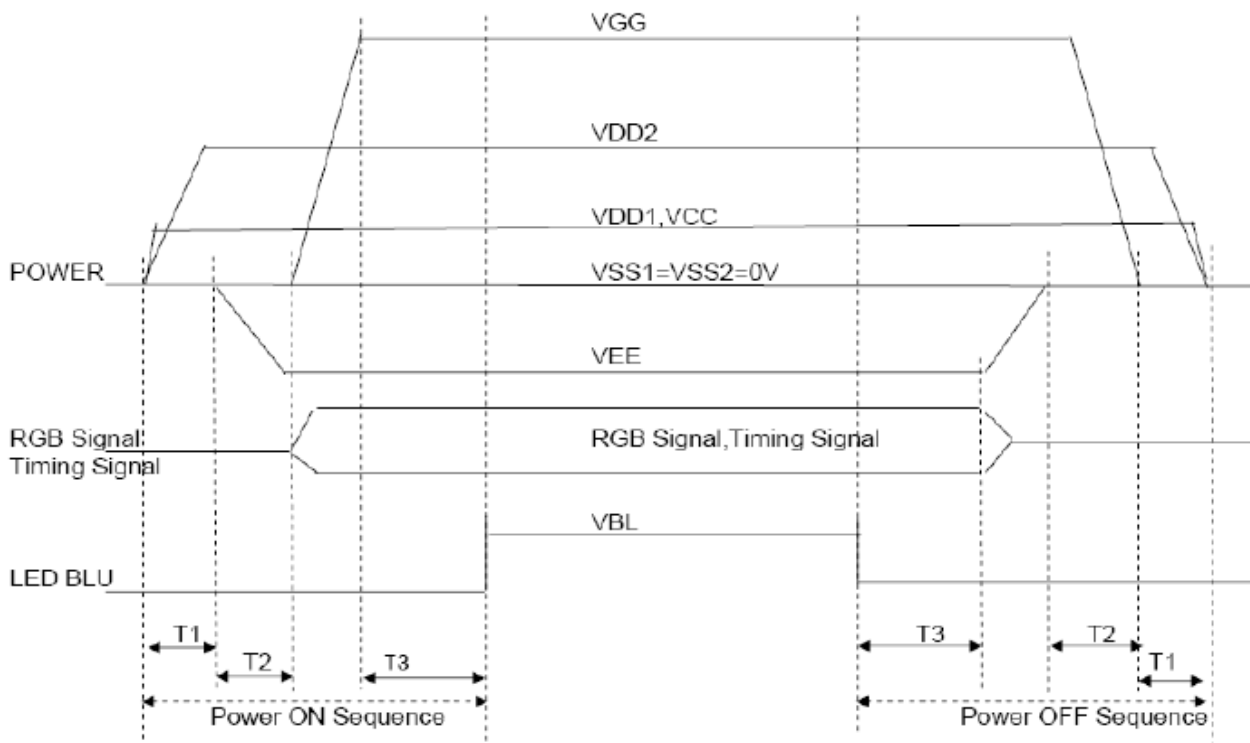

NOTE: T1 ≥ 10ms; T2 ≥ 20ms; T3 ≥ 100ms;

TIANMA CC



6 Optical Characteristics

Ta=25°C

Item	Symbol	Condition	Min	Typ	Max	Unit	Remark
View Angles	θT	CR ≥ 10	50	60	-	Degree	Note2,3
	θB		60	70	-		
	θL		60	70	-		
	θR		60	70	-		
Contrast Ratio	CR	θ=0°	350	400	-		Note 3
Response Time	T _{ON}	25°C	-	25	40	ms	Note 4
	T _{OFF}						
Chromaticity	White	Backlight is on	x	0.265	0.315	0.365	Note 1,5
			y	0.284	0.334	0.384	
	Red		x	0.522	0.572	0.622	Note 1,5
			y	0.296	0.346	0.396	
	Green		x	0.293	0.343	0.393	Note 1,5
			y	0.533	0.583	0.633	
	Blue		x	0.098	0.148	0.198	Note 1,5
			y	0.044	0.094	0.144	
Uniformity	U		75	80	-	%	Note 6
NTSC			-	50	-	%	Note 5
Luminance	L		350	400	-	cd/m ²	Note 7

Test Conditions:

1. The ambient temperature is 25°C. And one LED current is 20mA,
2. The test systems refer to Note 1 and Note 2.



Note 1: Definition of optical measurement system.

The optical characteristics should be measured in dark room. After 5 Minutes operation, the optical properties are measured at the center point of the LCD screen. All input terminals LCD panel must be ground when measuring the center area of the panel.

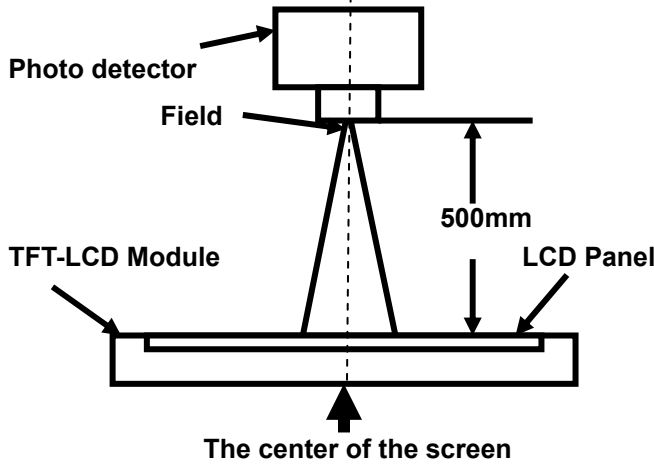

Item	Photo detector	Field
Contrast Ratio	SR-3A	1°
Luminance		
Chromaticity		
Lum Uniformity	BM-7A	2°
Response Time		

Note 2: Definition of viewing angle range and measurement system.

viewing angle is measured at the center point of the LCD by CONOSCOPE(ergo-80).

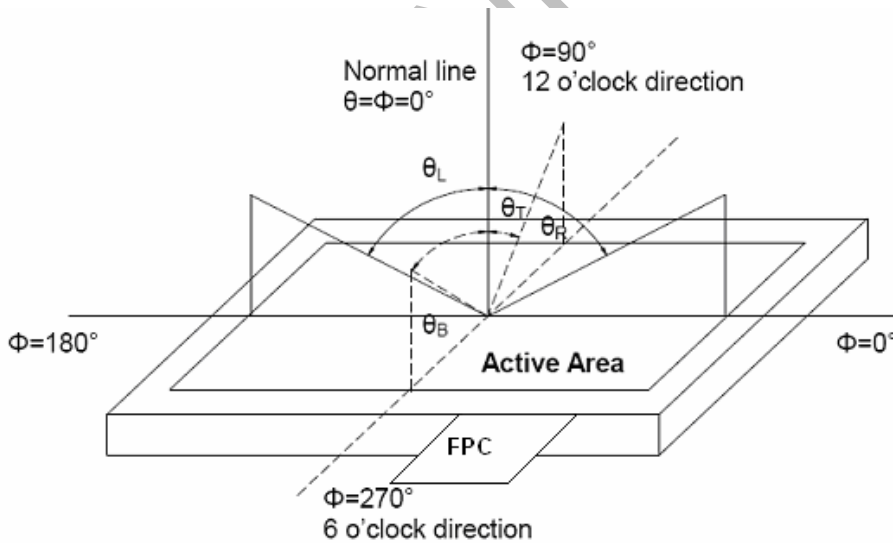

Note 3: Definition of contrast ratio

$$\text{Contrast ratio (CR)} = \frac{\text{Luminance measured when LCD is on the "White" state}}{\text{Luminance measured when LCD is on the "Black" state}}$$

“White state “:The state is that the LCD should driven by Vwhite.

“Black state”: The state is that the LCD should driven by Vblack.

Vwhite: To be determined Vblack: To be determined.

The information contained herein is the exclusive property of SHANGHAI TIANMA MICRO-ELECTRONICS Corporation, and shall not be distributed, reproduced, or disclosed in whole or in part without prior written permission of SHANGHAI TIANMA MICRO-ELECTRONICS Corporation.



Note 4: Definition of Response time

The response time is defined as the LCD optical switching time interval between “White” state and “Black” state. Rise time (TON) is the time between photo detector output intensity changed from 90% to 10%. And fall time (TOFF) is the time between photo detector output intensity changed from 10% to 90%.

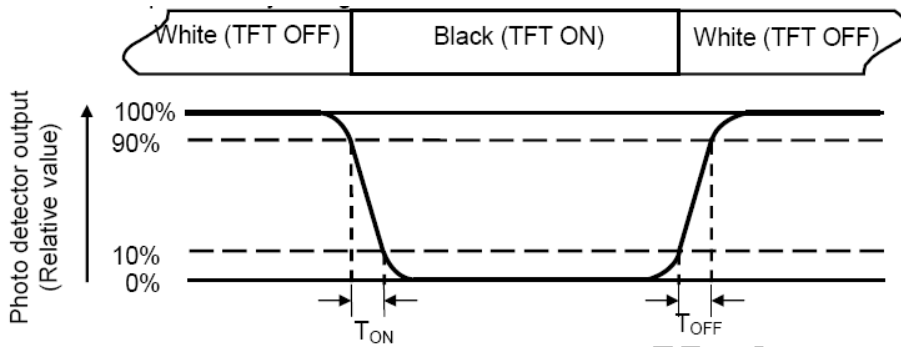

Note 5: Definition of color chromaticity (CIE1931)

Color coordinates measured at center point of LCD.

Note 6: Definition of Luminance Uniformity

Active area is divided into 9 measuring areas (Refer Fig. 2). Every measuring point is placed at the center of each measuring area.

Luminance Uniformity(U) = L_{min} / L_{max}

L-----Active area length W----- Active area width

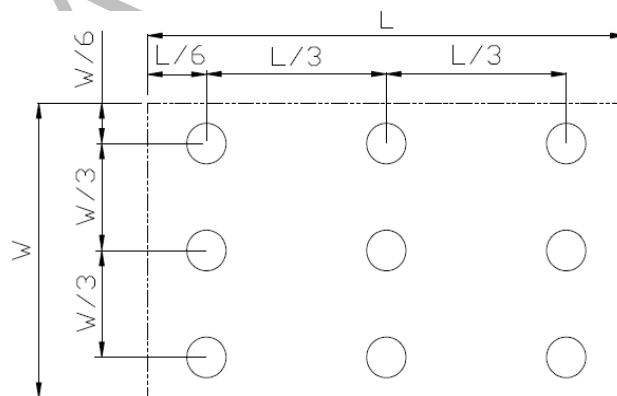

Lmax: The measured Maximum luminance of all measurement position.

Lmin: The measured Minimum luminance of all measurement position.

Note 7: Definition of Luminance :

Measure the luminance of white state at center point.



7 Environmental / Reliability Test

No	Test Item	Condition	Remarks
1	High Temperature Storage	Ta = +80°C, 240 hours	Note1 IEC60068-2-1,GB2423.2
2	Low Temperature Storage	Ta = -30°C, 240 hours	IEC60068-2-1 GB2423.1
3	High Temperature Operation	Ts = +70°C, 240 hours	IEC60068-2-1 GB2423.2
4	Low Temperature Operation	Ta = -20°C, 240 hours	IEC60068-2-1 GB2423.1
5	Operation at High Temperature and Humidity	Ta = +60°C, 90% RH Max,240hours	Note2 IEC60068-2-78 GB/T2423.3
6	Thermal Shock (non-operation)	-30°C 30 Min~+80°C 30 Min, Change time:5Min, 100 Cycle	Start with cold temperature, End with high temperature, IEC60068-2-14,GB2423.22
7	ESD	C=150pF,R=330Ω,5point/panel Air:±8KV,10times; Contact:±4KV,10times	IEC61000-4-2 GB/T17626.2
8	Vibration Test	Sine Wave Frequency range:10~55Hz Stroke:1.5mm Sweep:10Hz~55Hz~10Hz 2 hours for each direction of X.Y.Z. (6 hours for total)	IEC60068-2-6 GB/T2423.10
9	Mechanical Shock (Non Op)	Half Sine Wave 60G 6ms, ±X,±Y,±Z 3times for each direction	IEC60068-2-27 GB/T2423.5
10	Package Drop Test	Height:60cm , 1corner , 3edges , 6surfaces	IEC60068-2-34 GB/T2423.11

Note1: Ts is the temperature of panel's surface.

Note2: Ta is the ambient temperature of samples.



8 Mechanical Drawing

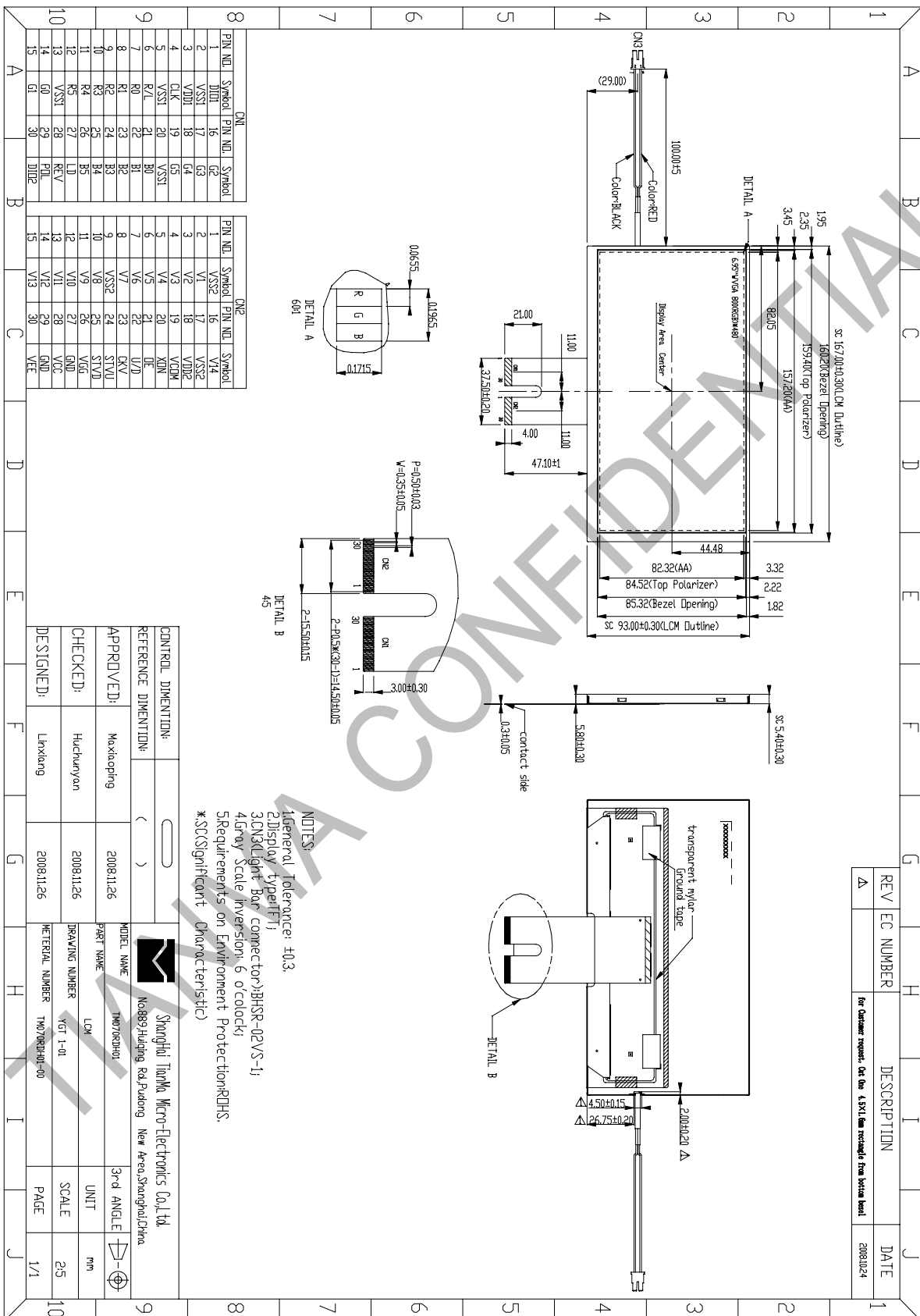

The information contained herein is the exclusive property of SHANGHAI TIANMA MICRO-ELECTRONICS Corporation, and shall not be distributed, reproduced, or disclosed in whole or in part without prior written permission of SHANGHAI TIANMA MICRO-ELECTRONICS Corporation.



9 Packing Drawing

No	Item	Model(Material)	Dimensions (mm)	Unit Weight (Kg)	Quantity	Remark
1	LCM	-	167.00x93.00x5.40	0.138	50	
2	Partition_1	Corrugated Paper	513x333x215	1.571	1	
3	Anti-static Bag	PE	180x160x0.05	0.01	50	Anti-static
4	Dust-Proof Bag	PE	700x530	0.06	1	
5	Partition_2	Corrugated Paper	505x332x4.0	0.1	2	
6	Corrugated Bar	Corrugated Paper	513x146x19.5	0.057	4	
7	Carton	Corrugated Paper	530x350x250	1.12	1	
8	Total Weight	10.579				

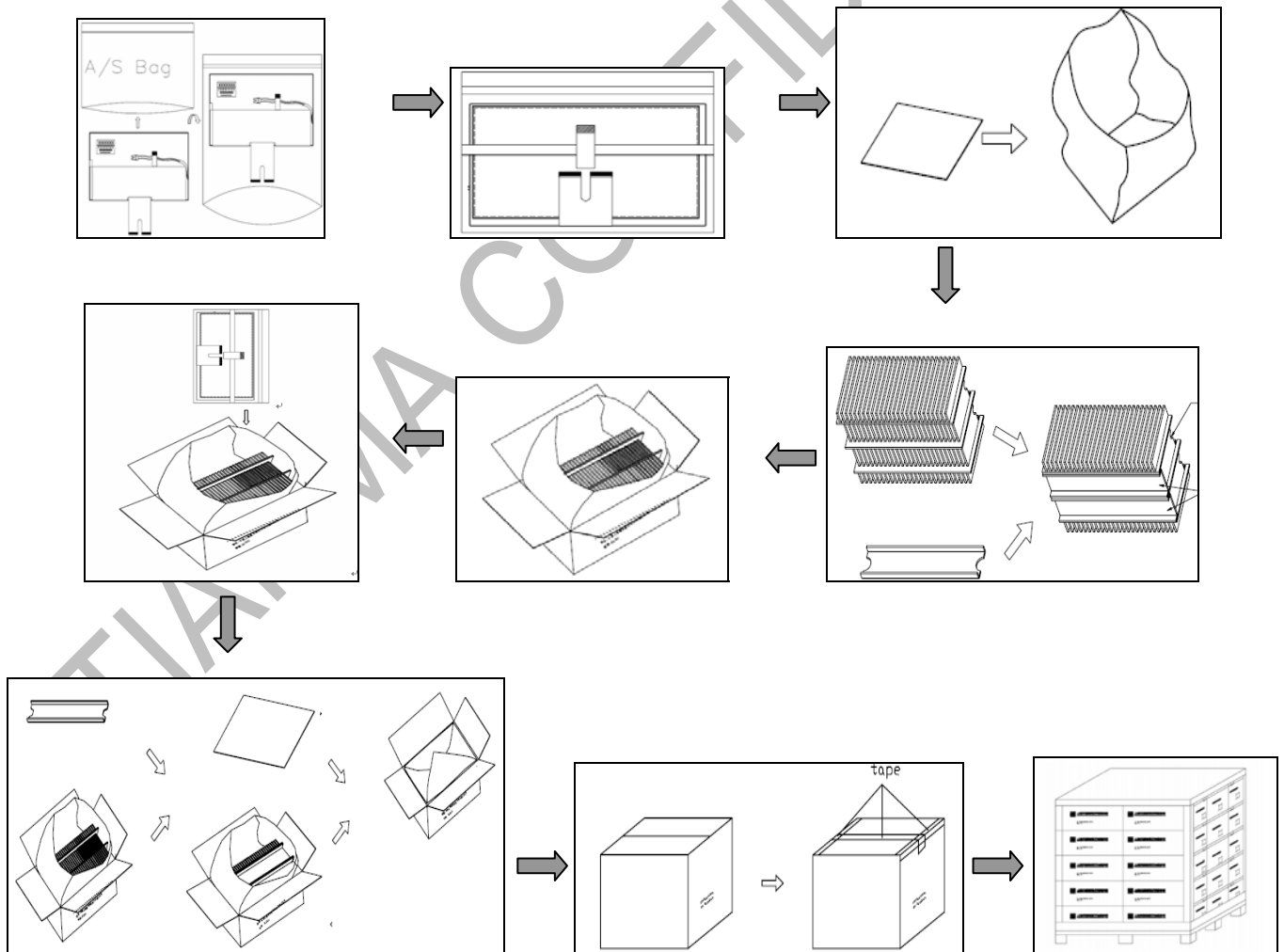

The information contained herein is the exclusive property of SHANGHAI TIANMA MICRO-ELECTRONICS Corporation, and shall not be distributed, reproduced, or disclosed in whole or in part without prior written permission of SHANGHAI TIANMA MICRO-ELECTRONICS Corporation.



TIANMA CONFIDENTIAL



10 Precautions for Use of LCD Modules

- a) Handling Precautions
- i. The display panel is made of glass. Do not subject it to a mechanical shock by dropping it from a high place, etc.
 - ii. If the display panel is damaged and the liquid crystal substance inside it leaks out, be sure not to get any in your mouth, if the substance comes into contact with your skin or clothes, promptly wash it off using soap and water.
 - iii. Do not apply excessive force to the display surface or the adjoining areas since this may cause the color tone to vary.
 - iv. The polarizer covering the display surface of the LCD module is soft and easily scratched. Handle this polarizer carefully.
 - v. If the display surface is contaminated, breathe on the surface and gently wipe it with a soft dry cloth. If still not completely clear, moisten cloth with one of the following solvents:
 - Isopropyl alcohol
 - Ethyl alcohol
 - vi. Solvents other than those mentioned above may damage the polarizer. Especially, do not use the following:
 - Water
 - Ketone
 - Aromatic solvents
 - vii. Do not attempt to disassemble the LCD Module.
 - viii. If the logic circuit power is off, do not apply the input signals.
 - ix. To prevent destruction of the elements by static electricity, be careful to maintain an optimum work environment.
 - b) Be sure to ground the body when handling the LCD Modules.
 - c) Tools required for assembly, such as soldering irons, must be properly ground.
 - d) To reduce the amount of static electricity generated, do not conduct assembly and other work under dry conditions.
 - e) The LCD Module is coated with a film to protect the display surface. Be care when peeling off this protective film since static electricity may be generated.
 - f) Storage precautions
 - i. When storing the LCD modules, avoid exposure to direct sunlight or to the light of fluorescent lamps.
 - ii. The LCD modules should be stored under the storage temperature range. If the LCD modules will be stored for a long time, the recommend condition is:
 - g) Temperature : 0°C ~ 40°C Relatively humidity: ≤80%
 - i. The LCD modules should be stored in the room without acid, alkali and harmful gas.
 - ii. Transportation Precautions
 - h) The LCD modules should be no falling and violent shocking during transportation, and also should avoid excessive press, water, damp and sunshine.

The information contained herein is the exclusive property of SHANGHAI TIANMA MICRO-ELECTRONICS Corporation, and shall not be distributed, reproduced, or disclosed in whole or in part without prior written permission of SHANGHAI TIANMA MICRO-ELECTRONICS Corporation.