



INNOVATIVE DISPLAY TECHNOLOGIES

17171 MURPHY AVENUE

IRVINE, CALIFORNIA 92614-5915

P: 949-417-8070/F: 949-417-8075

E-mail: info@shellyinc.com

Website: www.shellyinc.com

Specification

Part Number : **SCA07010-BFN-LRA**

Customer :

APPROVED BY: (FOR CUSTOMER USE ONLY)	PCB VERSION:	DATE:
--	---------------------	--------------

SOLD BY	APPROVED BY	CHECKED BY	ISSUE DATE

CONTENTS

NO.	ITEM	PAGE
1.	COVER	1
2.	RECORD OF REVISION	2
3.	GENERAL SPECIFICATION	3
4.	MECHANICAL DATA	3
5.	ABSOLUTE MAXIMUM RATINGS	4
6.	ELECTRICAL CHARACTERISTICS	5
7.	OPTICAL CHARACTERISTICS	6~8
8.	OUTLINE DIMENSION	9
9.	BLOCK DIAGRAM	10
10.	INPUT TERMINAL PIN ASSIGNMENT	11~12
11.	TIMING CHARACTERISTICS	13~14
12.	RELIABILITY TEST ITEMS	14
13.	TOUCH SCREEN PANEL SPECIFICATIONS	15
14.	GENERAL PRECAUTIONS	16~17

ACCEPTED BY :

PROPOSED BY :

3. General specifications

3.1 General specifications

It is a color active matrix TFT (Thin Film Transistor) liquid crystal display (LCD) that uses the amorphous silicon TFT as a switching devices. This model is composed of a Transmissive type TFT-LCD Panel, a driver circuit and a back-light unit.

3.2 Features

- High image quality a-Si TFT LCD module.
- 262K color number.
- Support (RGB) input mode
- High contrast, high brightness
- Low power consumption.

4. Mechanical data

No	Item	Specification	Remark
1	Type	Transmissive	--
2	Display Mode	Normally White	--
3	Pixel Element	a-Si TFT	--
4	Screen Size	7.0 inch	--
5	Resolution	800(RGB) x 480	--
6	Color Number	262K	--
7	Active Area	152.4(W) x 91.44(L) (mm)	--
8	PIXEL SIZE	0.1905 x 0.1905 (mm)	--
9	Color Arrangement	RGB-stripe	--
10	Assembly Type	COG	--
11	Back Light	LED	--
12	Viewing Direction	6 o'clock	--
13	Weight	TBD	--
14	Module Dimension	165.0(W) x 104.0(L) x 6.5(H)	--



5. Absolute maximum ratings

5.1 Electrical absolute maximum ratings

(1) TFT-LCD Panel Absolute Maximum Ratings

Ta=25°C GND=0V

Item	Symbol	Condition	Standard Value		Unit	Remark
			Min.	Max.		
Power supply voltage	VCC	GND=0V	-0.3	6.0	V	
	Vi	--	-0.3	6.3	V	--

* If the LSI is used above these absolute maximum ratings, it may become permanently damaged. Using the LSI within the following electrical characteristics limit is strongly recommended for normal operation. If these electrical characteristic conditions are also exceeded, the LSI will malfunction and cause poor reliability.

5.2 Environmental absolute maximum ratings

Item	Symbol	Min.	Max.	Unit	Remark
Operation temperature range	Top	-20	70	°C	Ambient
Storage temperature range	Tst	-30	80	°C	Ambient

- (1) Corrosive gas environment is not acceptable.
- (2) TFT-LCD color will change slightly depending on environment temperature. This phenomenon is reversible.
- (3) Current reduction rate of LED backlight is according to the graph indicated below:

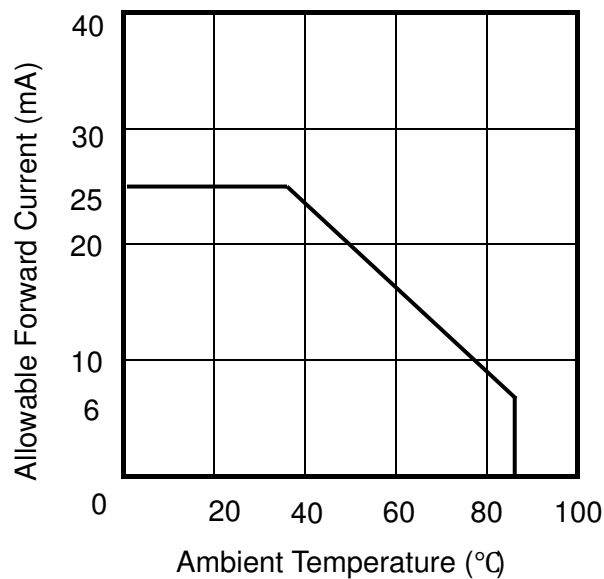

6. Electrical characteristics

(1)TFT-LCD Module

Ta=25°C

Item	Symbol	Min.	Typ.	Max.	Unit	Remark
Power Supply For LCD	VCC	3.0	3.3	3.5	V	Note(1)
Input Voltage	VIH	0.7VCC	--	VCC	V	H level
	VIL	0	--	0.3VCC	V	L level
LCD Power Current	ICC	--	300	350	mA	

(2) Back-Light Unit

Ta=25°C

Item	Symbol	Min.	Typ.	Max.	Unit	Remark
Power Supply for LED	VLED	4.8	5.0	5.2	V	Note(2)
LED Power Current	ILED	----	500	550	mA	Note(3)

NOTE(1):VCC setting should match the signals output voltage of customer's system board

NOTE(2):LED Driver driving voltage

NOTE(3): LED Driver driving current

7. Optical characteristics

Ta = 25°C, If=500mA \triangleup

Item		Symbol	Condition	Min.	Typ.	Max.	Unit	Note	
\triangleup	Brightness		Normal viewing angle At the center of panel	200	240	--	cd/m ²	(1)	
	Contrast Ratio			400	500	--	--	(2)	
	Response Time			Tr + Tf	--	25	50	ms	(3)
	Color chromaticity	White		W _x	0.26	0.31	0.36	--	--
				W _y	0.28	0.33	0.38		
Viewing Angle	Top	θ_U	CR \geq 10 Backlight On	40	50	--	degrees	(4)	
	Bottom	θ_D		60	70	--			
	Left	θ_L		60	70	--			
	Right	θ_R		60	70	--			
Uniformity		Un	$\theta=0^\circ$ Normal viewing angle	70	75	--	%	(5)	

Note 1: The brightness test equipment setup

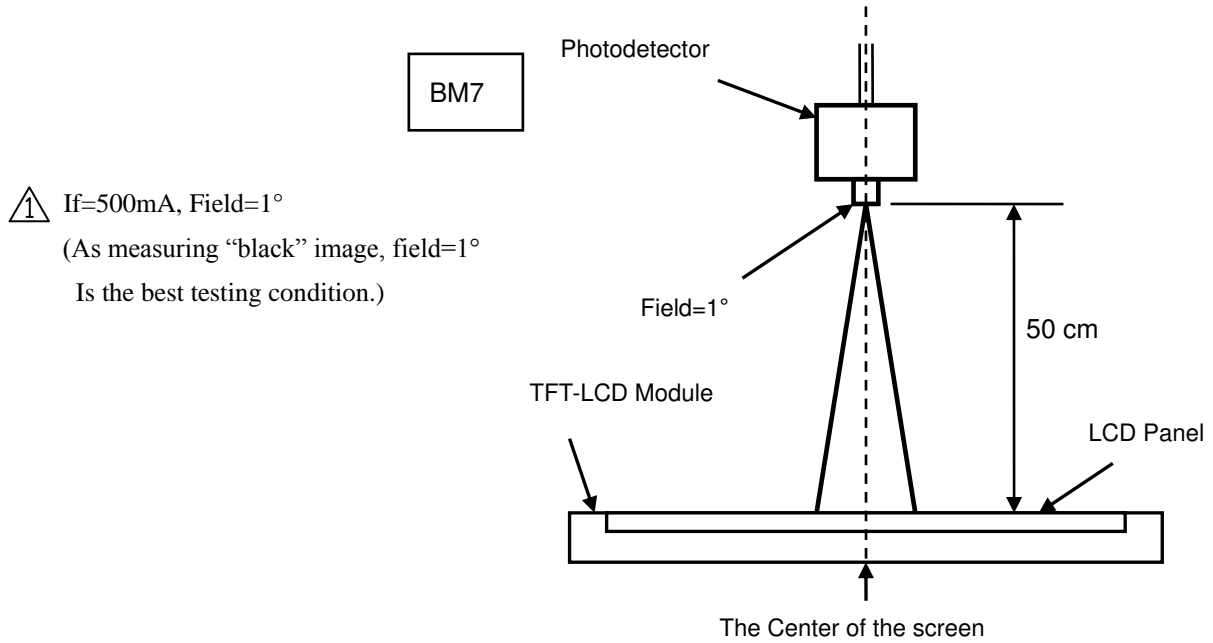

⚠ If=500mA, Field=1°
 (As measuring “black” image, field=1°
 Is the best testing condition.)

Note 2: Definition of contrast Ratio (C.R)

$$C.R = \frac{\text{Brightness When LCD is at "White" State}}{\text{Brightness When LCD is at "Black" State}}$$

Note 3: Definition of response time

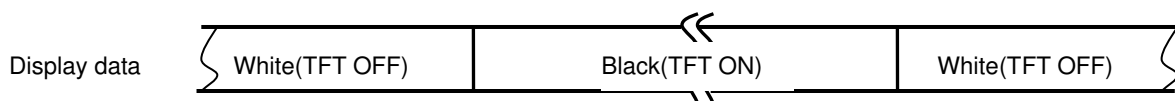
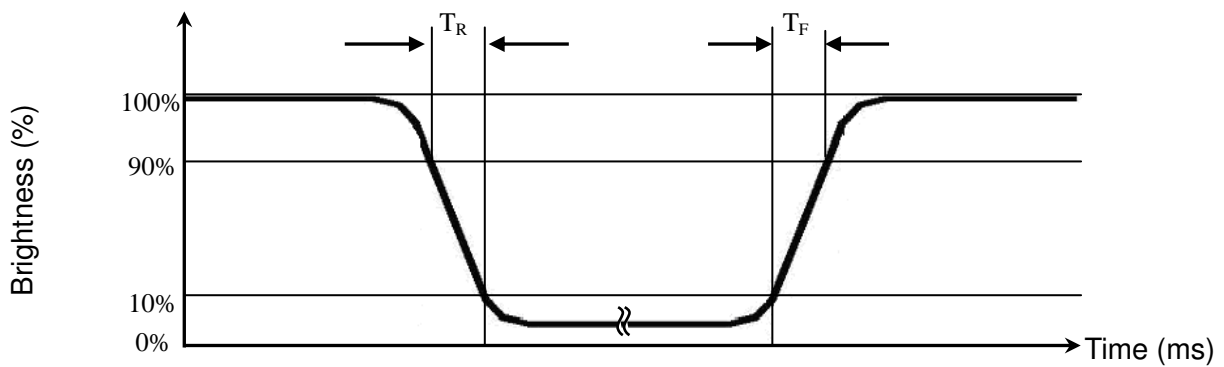

Note 4: Definition of viewing angle

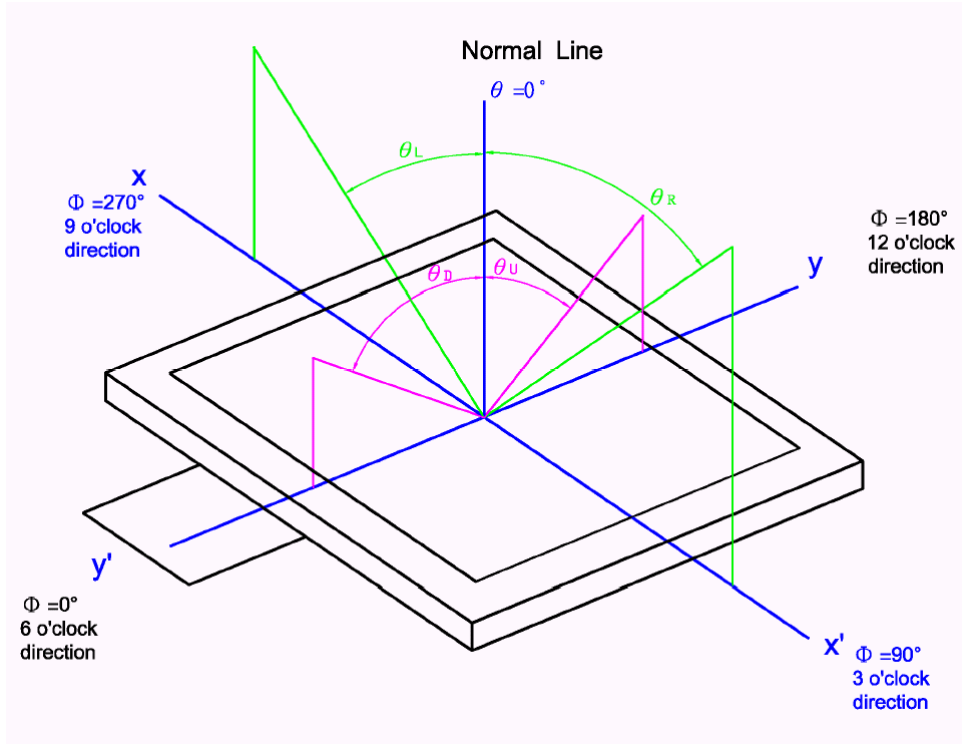

Note 5: Definition of uniformity (Un)

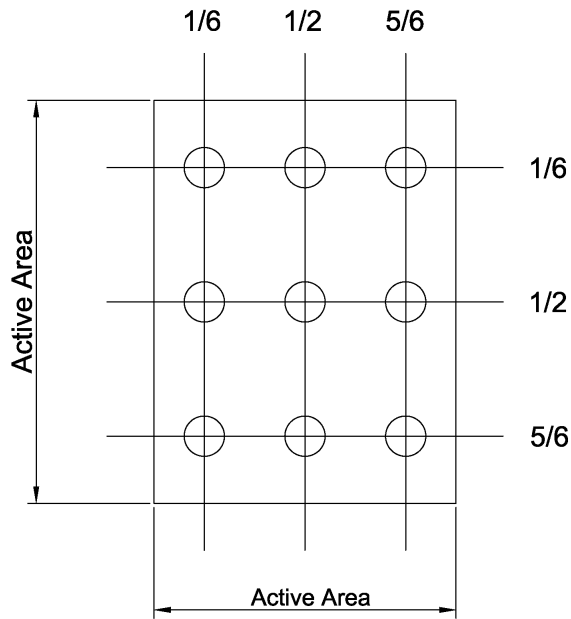

$$U_n = \frac{B_{\min}}{B_{\max}} \times 100\%$$

8. Outline dimension

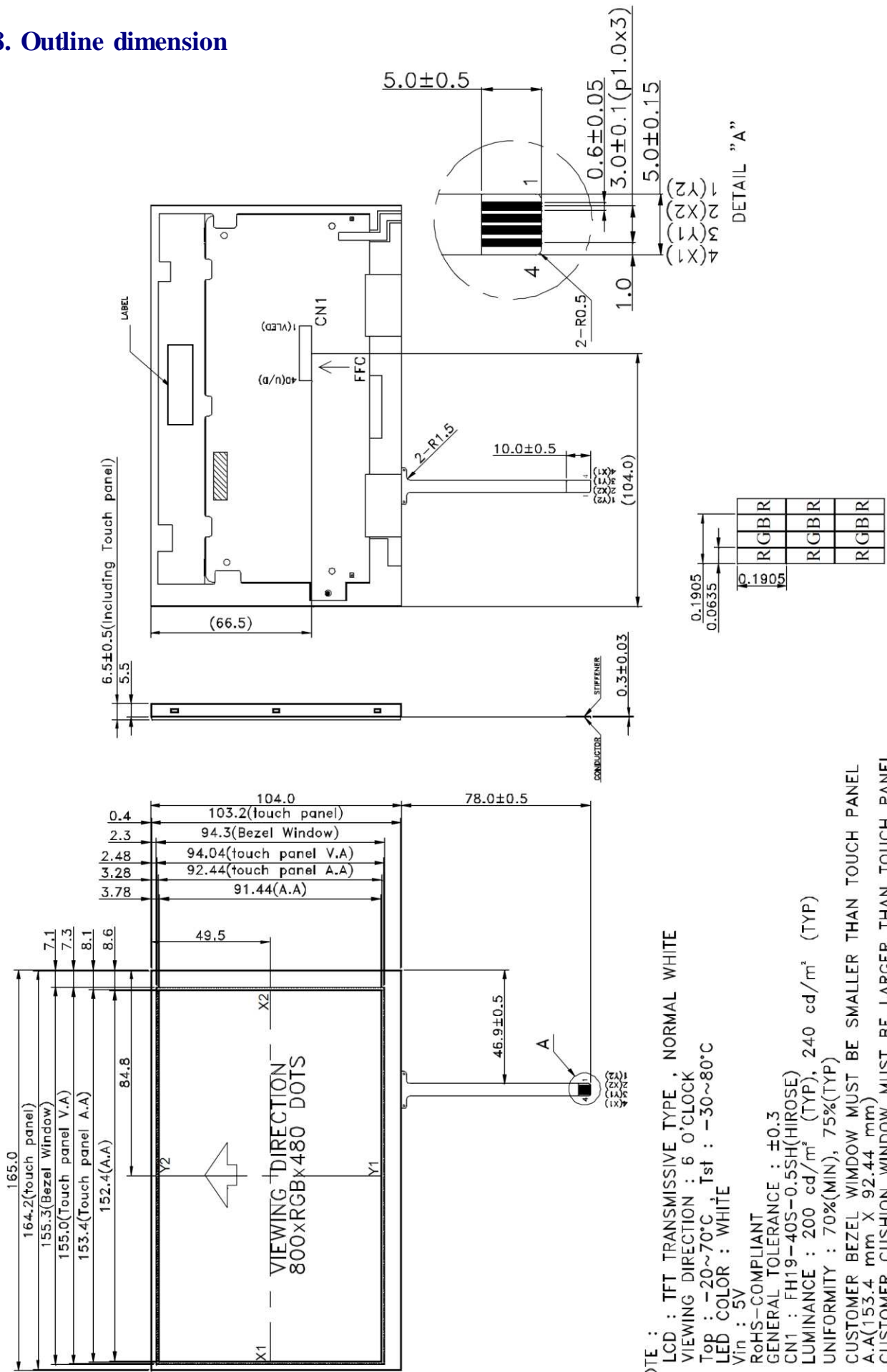

NOTE :
 1. LCD : TFT TRANSMISSIVE TYPE , NORMAL WHITE
 2. VIEWING DIRECTION : 6 O'CLOCK

3. TOP : -20~70°C Tst : -30~80°C

4. LED COLOR : WHITE
 V_{in} : 5V

5. RoHS-COMPLIANT

6. GENERAL TOLERANCE : ±0.3

7. CN1 : FH19-40S-0.5SH(HIROSE)

8. LUMINANCE : 200 cd/m² (TYP), 240 cd/m² (TYP)

9. UNIFORMITY : 70%(MIN), 75%(TYP)

10. CUSTOMER BEZEL WINDOW MUST BE SMALLER THAN TOUCH PANEL

A.A(153.4 mm X 92.44 mm)

11. CUSTOMER CUSHION WINDOW MUST BE LARGER THAN TOUCH PANEL

V.A(155.0 mm X 94.04 mm)0.5 mm

10. Input Terminal Pin Assignment

10.1 Input Signal & Power

CN1

Pin no	Symbol	Description	Remark
1	VLED	Power supply for LED Driver	-----
2	VLED	Power supply for LED Driver	-----
3	ADJ	Adjust the led brightness with PWM Pulse	NOTE.1
4	GLED	Ground for LED Driver	-----
5	GLED	Ground for LED Driver	-----
6	VCC	Power Supply for LCM	-----
7	VCC	Power Supply for LCM	-----
8	MODE	DE or HV mode control	NOTE.2
9	DE	Data Enable	-----
10	VS	Vsync signal input	-----
11	HS	Hsync signal input	-----
12	VSS	Ground	-----
13	B5	Blue Data Input	-----
14	B4	Blue Data Input	-----
15	B3	Blue Data Input	-----
16	VSS	Ground	-----
17	B2	Blue Data Input	-----
18	B1	Blue Data Input	-----
19	B0	Blue Data Input	-----
20	VSS	Ground	-----
21	G5	Green Data Input	-----
22	G4	Green Data Input	-----
23	G3	Green Data Input	-----
24	VSS	Ground	-----
25	G2	Green Data Input	-----
26	G1	Green Data Input	-----
27	G0	Green Data Input	-----
28	VSS	Ground	-----
29	R5	Red Data Input	-----
30	R4	Red Data Input	-----
31	R3	Red Data Input	-----
32	VSS	Ground	-----
33	R2	Red Data Input	-----
34	R1	Red Data Input	-----
35	R0	Red Data Input	-----
36	VSS	Ground	-----

Pin no	Symbol	Description	Remark
37	DCLK	Dot Clock	-----
38	VSS	Ground	-----
39	L/R	Select left or right scanning direction	NOTE.3
40	U/D	Select up or down scanning direction	NOTE.3

Touch Panel

Pin no	Symbol	Description	Remark
1	Y2	Top electrode – differential analog	-
2	X2	Right electrode – differential analog	-
3	Y1	Bottom electrode – differential analog	-
4	X1	Left electrode – differential analog	-

NOTE(1):ADJ adjust brightness to control PIN, pulse duty the bigger the brighter
 ADJ signal=0~3.3v;Operating frequency:100~300Hz

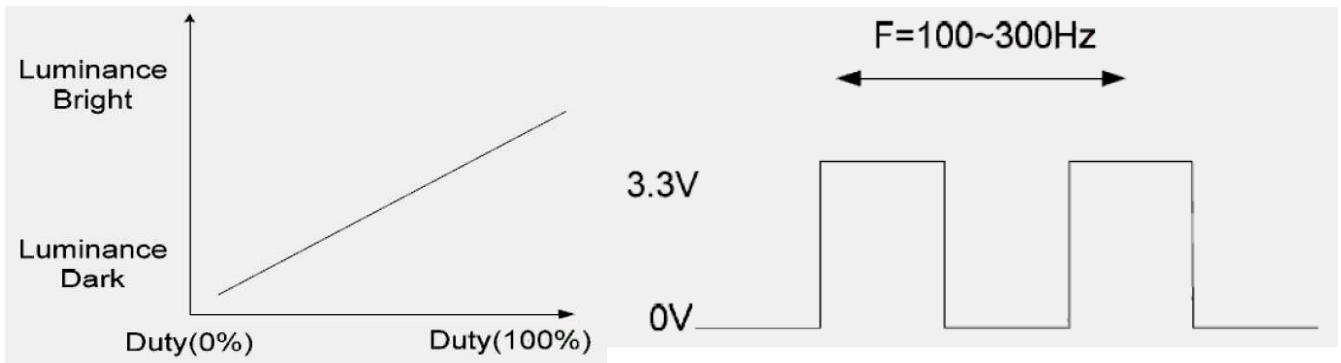

NOTE(2):DE Mode: "H",HS floating and VS floating
 HV Mode: "L" and DE floating

NOTE(3):

Setting of scan control input		Scanning direction
U/D	L/R	
GND	V _{CC}	Up to down, left to right
V _{CC}	GND	Down to up, right to left
GND	GND	Up to down, right to left
V _{CC}	V _{CC}	Down to up, left to right

11. Timing Characteristics

Items		Symbol	Min.	Typ	Max.	Unit
DCLK	Period	tCLK	20.0	30.0		ns
	Frequency	fCLK	-	33.3	50	MHz
	Low Level Width	tWCL	6			ns
	High Level Width	tWCH	6			ns
	Rise/Fall Time	tCLKr, tCLKf			3	ns
	Duty	-	0.45	0.50	0.55	ns
DE	Setup Time	tDES	5			ns
	Hold Time	tDEH	10			ns
	Rise/Fall Time	tDEr, tDEf			16	ns
	Horizontal Period	tHP		928		tCLK
	Horizontal Valid	tHV		800		tCLK
	Horizontal Blank	tHBK		tHP - tHV		tCLK
	Vertical Period	tVP		525		tHP
	Vertical Valid	tw		480		tHP
	Vertical Blank	tVBK		tVP - tw		tHP
DATA	Setup Time	tDS	5			ns
	Hold Time	tDH	10			ns
	Rise/Fall Time	tDr, tDf	-	-	3	ns

11.1 DE and RGB Input Timing

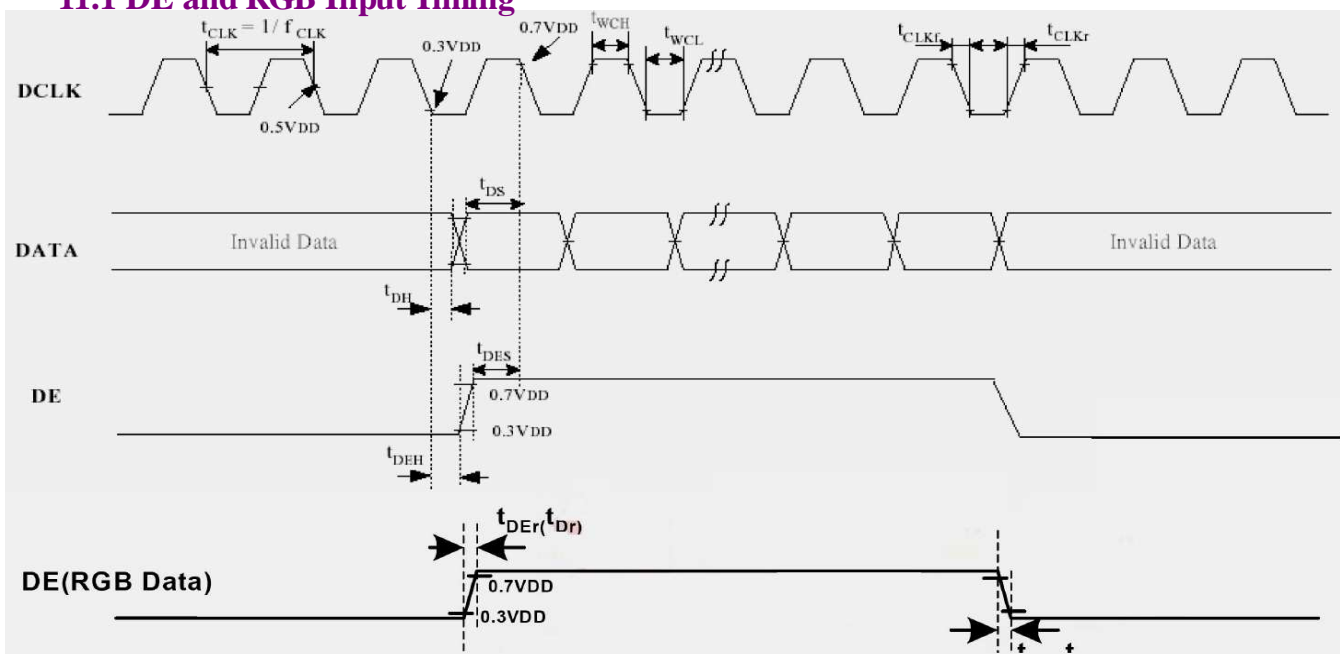

11.2 Power Sequence

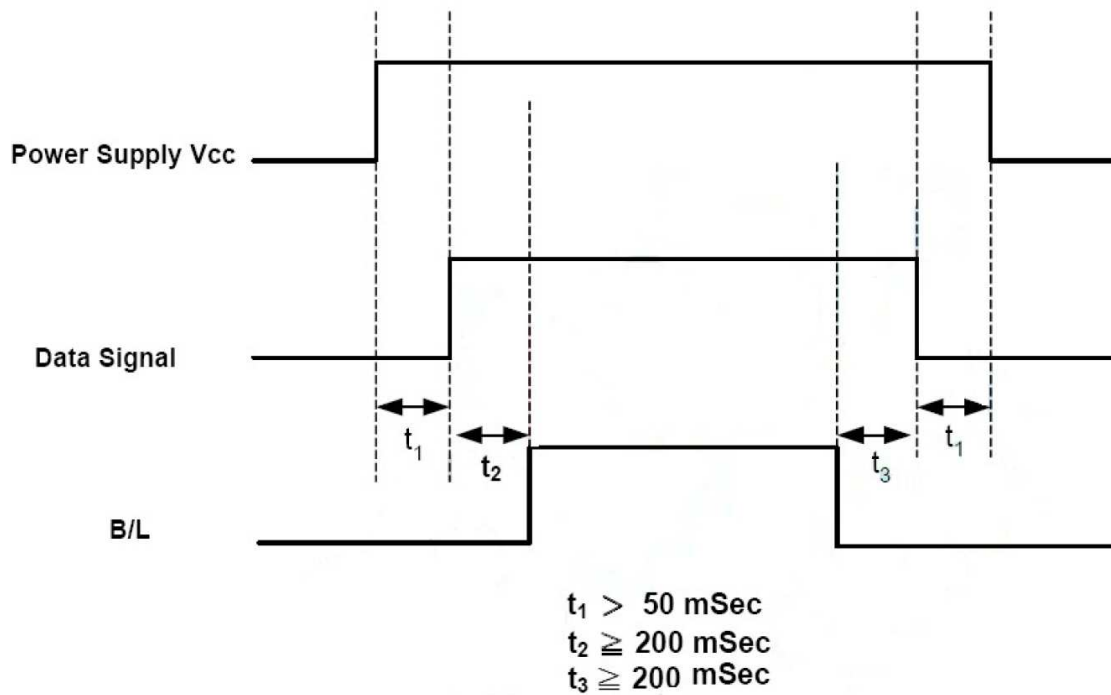

12. Reliability Test Items

No.	Test items	Conditions	Remark
1	High temperature storage	80°C 240H	--
2	Low temperature storage	-30°C 240H	--
3	High temperature & high humidity storage	40°C 90% RH, 240H	--
4	Vibration test	Freq.:10~55~10~55~10 Hz within 1 minutes, Amp.:1.5 mm 120minutes for each direction of X, Y, Z	Non-operation
5	Thermal Shock	-30°C,30 min / 80°C,30 min , 100 cycles	Static
6	High temperature operation	70°C 240H	--
7	Low temperature operation	-20°C 240H	--

Criterion: There should be no change which might affect the practical display function when the display quality test is conducted under normal operating condition.

13. Touch Screen Panel Specifications

13.1 Electronic Characteristics

Item	Min.	Typ.	Max.	Unit	NOTE
Linearity	-	-	(1.5)	%	-
Terminal Resistance	(200)	-	-	Ω	X(Film side)
	(200)	-	-	Ω	Y(Film side)
Insulation Resistance	(20)	-	-	M Ω	DC 25V
Voltage	-	-	(5)	V	DC
Chattering	-	-	(10)	ms	ON/OFF
Transparency		(80)	-	%	Non-glare

Note: Do not operate it with a thing except a polyacetal pen (tip R0.8mm or less) or a finger, especially those with hard or sharp tips such as a ball point pen or a mechanical pencil.

13.2 Mechanical & Reliability Characteristics

Item	Min.	Typ.	Max.	Unit	NOTE
Activation force	-	-	100	g	(1)
Durability-surface scratching	(Write) (100,000)	-	-	characters	(2)
Durability-surface pitting	(1,000,000)	-	-	touches	(3)
Surface hardness	(3)	-	-	H	JIS K5400, ASTM D3363

NOTE: (1) Stylus pen Input : R0.8mm polyacetal pen or Finger

(2) Measurement for Surface area

-100,000 times or over

-Writing with R0.8mm plastic stylus pen ; writing force 150g in active area.

-Speed is 60mm/sec

(3) 1,000,000 times or over (No damage on film surface)

14. General Precautions

Please pay attentions to the followings as using the LCD module.

14.1 Handling

- (a) Do not apply strong mechanical stress like drop, shock or any force to LCD module. It may cause improper operation, even damage.
- (b) Because the polarizer is very fragile and easy to be damaged, do not hit, press or rub the display surface with hard materials.
- (c) Do not put heavy or hard material on the display surface, and do not stack LCD modules.
- (d) If the display surface is dirty, please wipe the surface softly with cotton swab or clean cloth.
- (e) Avoid using Ketone type materials (e.g. Acetone), Toluene, Ethyl acid or Methyl chloride to clean the display surface. It might damage the polarizer permanently. The recommended solvents are water and Isopropyl alcohol.
- (f) Wipe off water droplets or oil immediately.
- (g) Protect the LCD module from ESD. It will damage the LSI and the electronic circuit.
- (h) Do not touch the output pins directly with bare hands.
- (I) Do not disassemble the LCD module.

14.2 Storage

- (a) Do not leave the LCD modules in high temperature, especially in high humidity for a long time.
- (b) Do not expose the LCD modules to sunlight directly.
- (c) The liquid crystal is deteriorated by ultraviolet. Do not leave it in strong ultraviolet ray for a long time.
- (d) Avoid condensation of water. It may cause improper operation.
- (e) Please stack only up to the number stated on carton box for storage and transportation. Excessive weight will cause deformation and damage of carton box.

14.3 Operation

- (a) When mounting or dismounting the LCD modules, turn the power off.
- (b) Protect the LCD modules from electric shock.
- (c) The Driver IC control algorithms should always obeyed to avoid damaging the LSI and electronic circuit.
- (d) Be careful to avoid mixing up the polarity of power supply for backlight.

- (e) Absolute maximum rating specified above has to be always kept in any case. Exceeding it may cause non-recoverable damage of electronic components or, nevertheless, burning.
- (f) When a static image is displayed for a long time, remnant image is likely to occur.
- (g) Be sure to avoid bending the FPC to an acute shape, it might break FPC.

14.4 Others

- (a) If the liquid crystal leaks from the panel, it should be kept away from the eyes or mouth.
- (b) For the fragility of polarizer, it is recommended to attach a transparent protective plate over the display surface.
- (c) It is recommended to peel off the protection film on the polarizer slowly so that the electrostatic charge can be minimized

Warranty:

Unless agreed between Shelly Associates Inc. and customer, Shelly will replace or repair any of its LCD modules which are found to be functionally defective when inspected in accordance with Shelly Associates Inc. acceptance standards (copies available upon request) for a period of one year from date of shipments. Cosmetic/visual defects must be returned to Shelly within 90 days of shipment. Confirmation of such date shall be based on freight documents. The warranty liability of Shelly Associates Inc. is limited to repair and/or replacement on the terms set forth above. Shelly Associates Inc. will not be responsible for any subsequent or consequential events.