



INNOVATIVE DISPLAY TECHNOLOGIES

17171 MURPHY AVENUE

IRVINE, CALIFORNIA 92614-5915

P: 949-417-8070/F: 949-417-8075

E-mail: [info@shellyinc.com](mailto:info@shellyinc.com)

Website: [www.shellyinc.com](http://www.shellyinc.com)

## Specification

**Part Number** : SCA05736-TFA-LRC

**Customer** :

**APPROVED BY:**  
( FOR CUSTOMER USE ONLY )

PCB VERSION:

DATE:

SOLD BY	APPROVED BY	CHECKED BY	ISSUE DATE

MODLE NO :

DOC. FIRST ISSUE

**RECORDS OF REVISION**

VERSION	DATE	REVISED PAGE NO.	<b>SUMMARY</b>
0	2009/3/6		First issue

# **Contents**

- 1. Module Classification Information**
- 2. General Specification**
- 3. Block Diagram**
- 4. Electrical Characteristics**
- 5. Absolute Maximum Ratings**
- 6. Interface Pin Function**
- 7. Optical Characteristics**
- 8. Contour Drawing**
- 9. Timing Characteristics**
- 10.LED driving conditions**
- 11.Timing Characteristics**
- 12.Touch panel Information**
- 13.Reliability**
- 14.Inspection specification**

# 1.Module Classification Information

SCA05736 – TFA – LRC

① ② ③ ④ ⑤ ⑥ ⑦ ⑧ ⑨ ⑩ ⑪

- ① Brand : Shelly Associates Inc.
- ② Display Type : SCA →TFT Type
- ③ Display Size : 5.7” TFT
- ④ Model serials no.
- ⑤ Backlight Type : L→LED, White
- ⑥ LCD Polarize Type/ Temperature range/ View direction F→Transmissive, T →W.T,12:00
- ⑦ C: TFT+FR+CONTROL BOARD A = Antiglare
- ⑧ F : 640x480
- ⑨ D: Digital
- ⑩ Version “0”
- ⑪ Special Code #:Fit in with ROHS directive regulations  
00 : Sales code 0 : Version ( Add TS )  
R = Touch panel

## 2.General Specification

NO.	ITEM	CONTENTS	UNIT
1	Module Size	127.14(W) x 100.94(H) x Max.9.8(D) Without FPC	mm
2	Pixel Size	0.18(W) x 0.18 (H)	mm
3	Active Area	115.2(W) x 86.40 (H)	mm
4	Number of Dots	640 RGB (W) x 480 (H)	Dot
5	LCD Display Mode	TFT 5.7',Normally White / Positive Image	-
6	Rear Polarizer	Color Transmissive Type	-
7	Viewing Direction	12	O'clock
8	Backlight	LED	-
9	Driver IC	Source:HX8250-A01B(DOG);Gate:HX8678-A000(COG)	-
10	Weight	125 (Approx)	g

### 3. Block Diagram

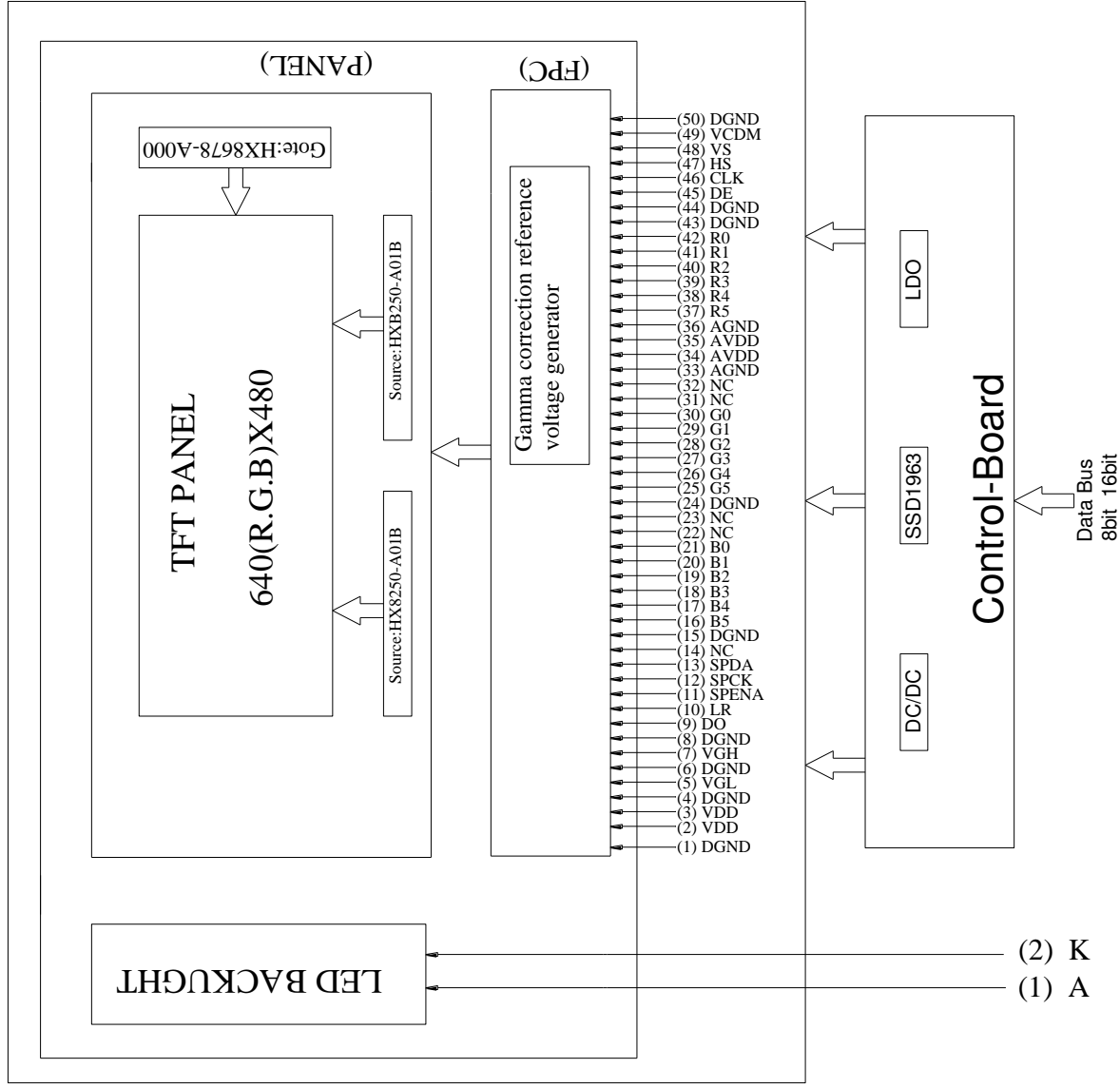

## 4. Electrical Characteristics

### 4-1. ELECTRICAL CHARACTERISTICS OF LCM

ITEM	SYMBOL	CONDITION	MIN.	TYP.	MAX.	UNIT
Power supply for logic	VDD	VDD-DGND	3.0	3.3	3.6	V
Output voltage	VOH	Output high voltage	0.8VDD			
	VOL	Output low voltage			0.2VDD	
Input Voltage	VIH	Input high voltage	0.8VDD	-	VDD +0.5	V
	VIL	Input low voltage			0.2VDD	
Recommended TFT Driving Current for 25°C	I <sub>VDD</sub>	VDD=3.3V	-	190	250	mA
Brightness	L	I <sub>AK</sub> =60mA Pattern :All on (White Color)	250.0	300.0	-	cd/m <sup>2</sup>

## 5. Absolute Maximum Ratings

### 5-1. ENVIRONMENTAL ABSOLUTE MAXIMUM RATINGS

ITEM	WIDE TEMP			
	OPERSTING		STORAGE	
	MIN.	MAX.	MIN.	MAX.
Ambient Temperature(°C)	-20	70	-30	80
Humidity (Without Condensation)	Note 2,4		Note 3,4	

Note 2 Ta ≤70°C:75%RH MAX.

Note 3 Please refer to item of reliability test.

Note 4 Background color will change slightly depending on ambient temperature.

That phenomenon is reversible.

## **6.Interface Pin Function**

LCD (CON2)

Pin No.	Symbol	Pin No.	Symbol
1	GND	16	UD
2	VDD	17	LR
3	VO	18	RST
4	A0	19	NC
5	R/W	20	NC
6	E		
7	DB0		
8	DB1		
9	DB2		
10	DB3		
11	DB4		
12	DB5		
13	DB6		
14	DB7		
15	CS		

LED BACKLIGHT (CN2): JST BHSR-02VS-1

Pin No.	Symbol
1	A
2	K

CORRESPONDABLE BACKLIGHT CONNECTOR : SM 02B-BHSS-1

## 7. OPTICAL CHARACTERISTICS

### 7-1 Optical Char. of LCD Panel

Parameter	SYMBOL	Values			Unit	Note
		Min.	Typ.	Max.		
Response Time	$T_r + T_f$	-	50	80	ms	NOTE 2,3
Contrast Ratio	C/R	150	250	-	-	*a)
$\theta$ ( Viewing Angle )	CR =10	12 O'Clock	-	60	-	NOTE3,5
		6 O'Clock	-	40	-	
$\phi$ ( Viewing Angle )		9 O'Clock	-	60	-	
		3 O'Clock	-	60	-	
Degree of Saturation	NTSC	-	53	-	%	

\*a) Contrast Ratio (CR) is define mathematically as:

$$\text{Contrast Ratio} = \frac{\text{Surface Luminance with all white pixels}}{\text{Surface Luminance with all black pixels}}$$

### 7-2.Coloe of CIE Coordinate

$T_a = 25^\circ\text{C}$

ITEM		SYMBOL	CONDITION	VALUE			NOTE
				MIN.	TYP.	MAX.	
Color of CIE Coordinate	Red	x	$\phi=0^\circ, \theta=0^\circ$	0.55	0.6	0.65	Note※
		y		0.31	0.36	0.41	
	Green	x	$\phi=0^\circ, \theta=0^\circ$	0.29	0.34	0.39	
		y		0.53	0.58	0.63	
	Blue	x	$\phi=0^\circ, \theta=0^\circ$	0.09	0.14	0.19	
		y		0.05	0.1	0.15	
	White	x	$\phi=0^\circ, \theta=0^\circ$	0.25	0.3	0.35	
		y		0.27	0.32	0.37	

Note✕ Measuring at position 3 on Fig.1 CIE chromaticity diagram.

Base on Winstar Backlight (CIE X = $0.30 \pm 0.03$ , Y= $0.30 \pm 0.03$ )

Fig.1

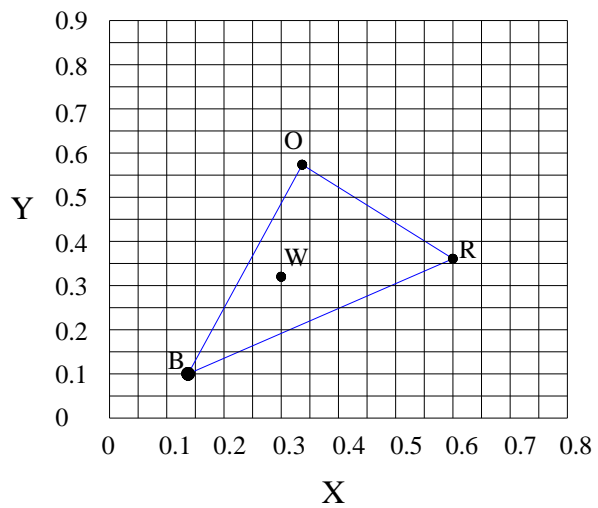

(NOTE 1)

Definition of Operation Voltage(Vop)

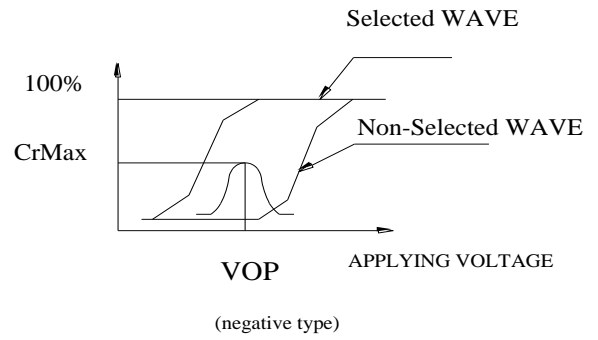
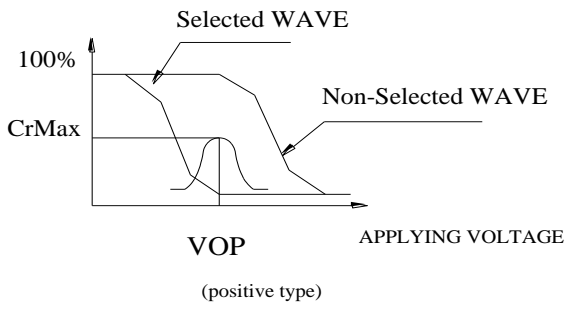

\*Conditions

Viewing Angle: 0

Farme Frequency :70 Hz

Applying Waveform : 1/N duty , 1/a bias

(NOTE 2)

Definition of Response Time(Tr,Tf)

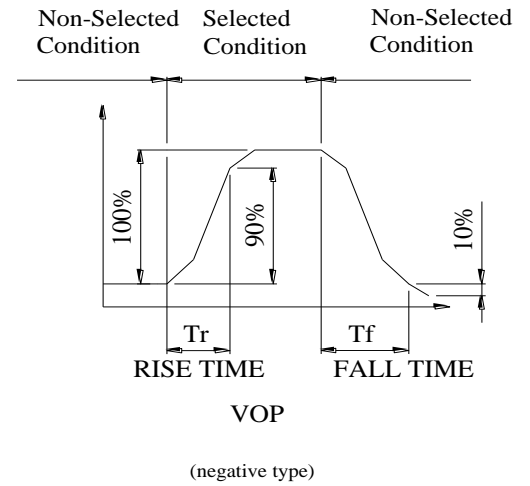
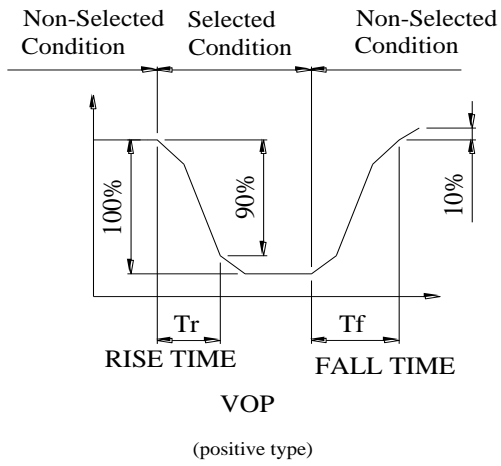

Operating Voltage: Vop  
 Viewing Arigle:  $(\theta, \phi)$  (0.0)  
 Frams Frequency: 70Hz  
 Applying Waveform: 1/N duty 1/a bias

**(NOTE 3)**

Description of Measuring Equipment and Driving Waveforms

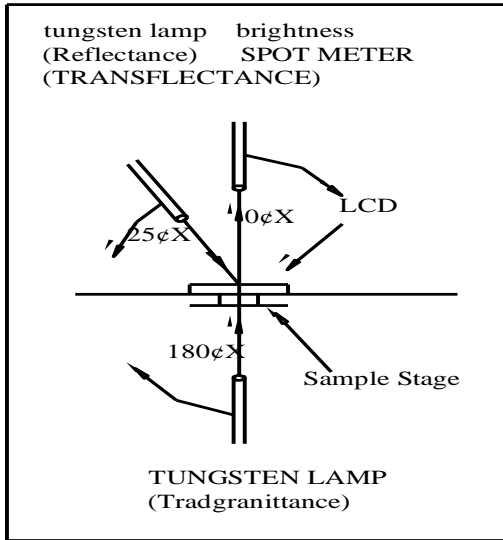

CONST.  
TEMP.  
CHAMEER.

(Note 4)  
Definition of Viewing Direction

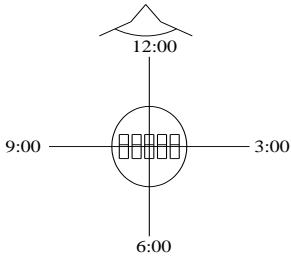

(Note 4)  
Definition of Viewing Angle

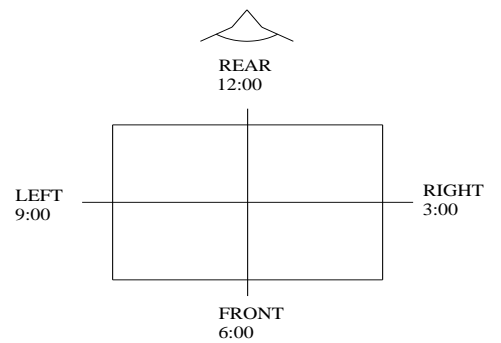
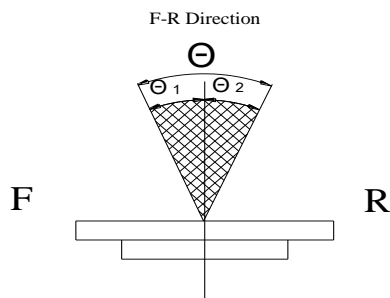
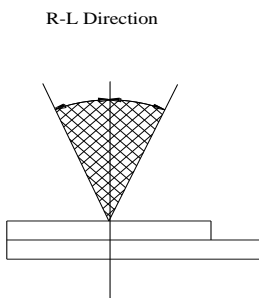

$$\theta = \theta_1 + \theta_2$$

**\*Condition**

Operating Voltage :Vop  
 Frame Frequency : 70Hz  
 Applying Waveform :1/N duty 1/a bias  
 Contrast Ratio : larger than 2

(NOTE 6)  
Definition of Contrast Ratio (Cr)

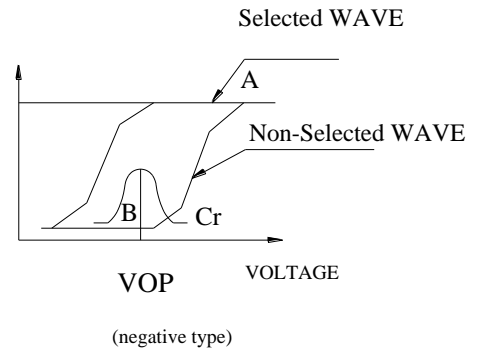
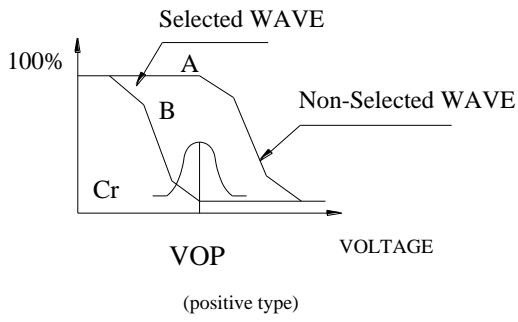

Contrast Ratio :  $Cr=A/B$

\*Conditions  
 Viewing Angle :0  
 Frame Frequency : 70Hz  
 Applying Waveform :1/N duty 1/a bias

# 8 Contour Drawing

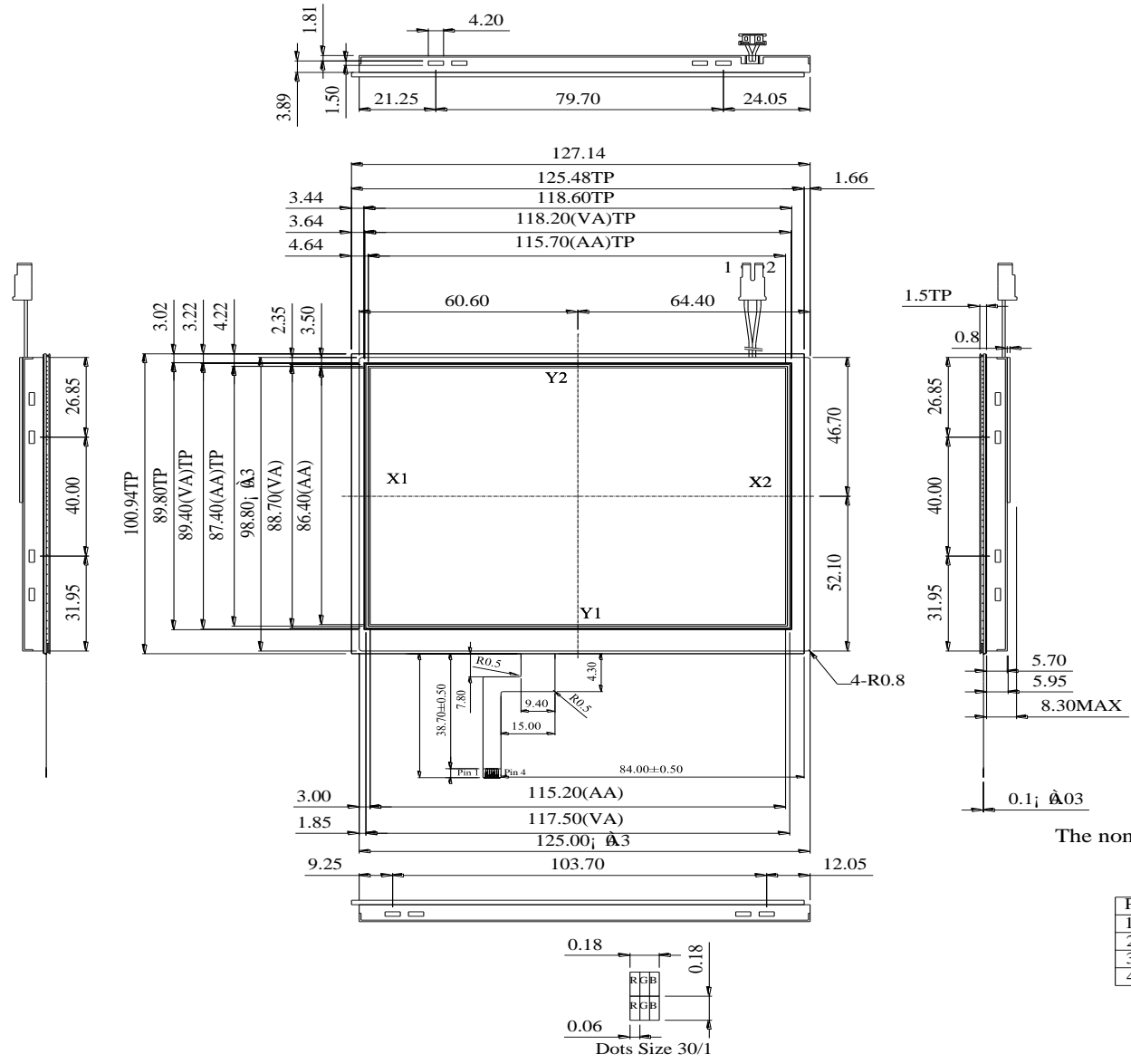

The non-specified tolerance of dimension is  $\pm 0.3\text{mm}$ .

# CON2

PIN NO.	SYMBOL
1	GND
2	VDD
3	VO
4	A0
5	R/W
6	E
7	DB0
8	DB1
9	DB2
10	DB3
11	DB4
12	DB5
13	DB6
14	DB7
15	CS
16	UD
17	LR
18	RST
19	NC
20	NC

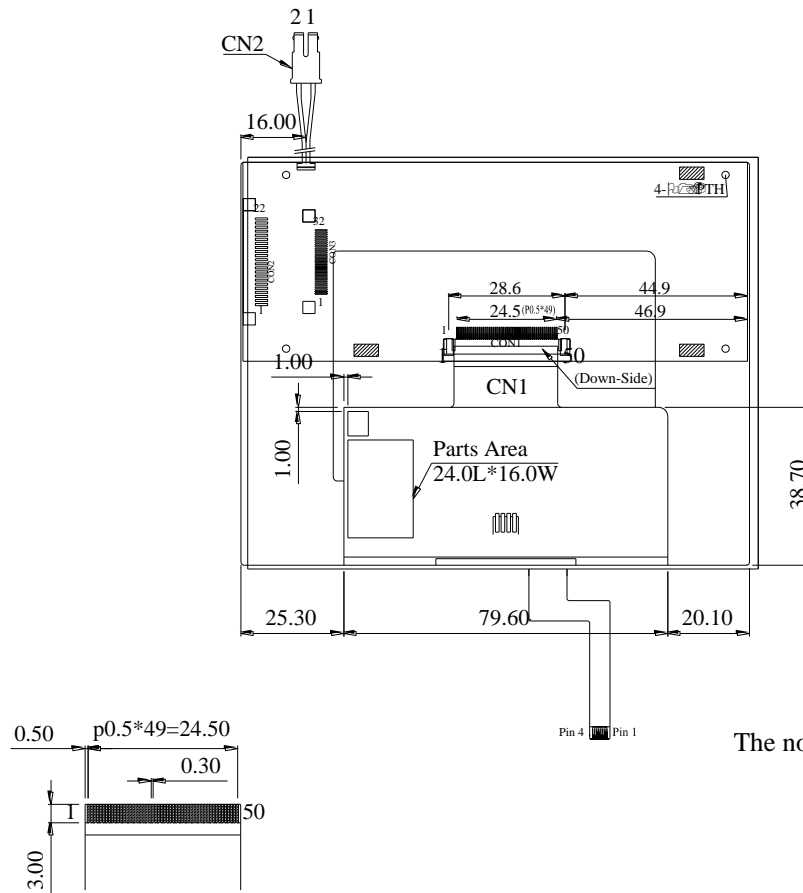

The non-specified tolerance of dimension is  $\pm 0.3\text{mm}$ .

# **9. TIMING CHARACTERISTICS**

## 9-1 . AC TIMING CHARACTERISTICS

Please refer to the IC SPEC :(Himax) HX8250-A01B

(Himax) HX8678-A000

( Himax Technologies, Inc )

## 9-2 POWER ON/OFF SEQUENCE

To prevent the devlce damage from latch up, the power ON/OFF sequence shown below must be followed.

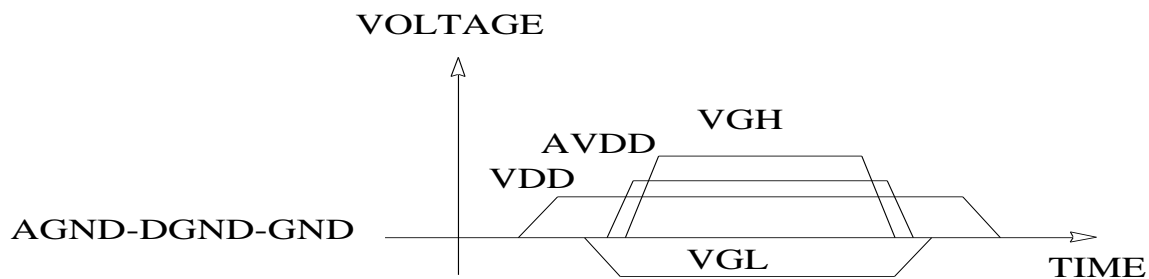

(NOTE) DISPLAY DIRECTION OF THE PANEL

The UD and LR control the Display direction of the panel.

The settings of UD and LR are as following:

- (1) **UD=VDD and LR=DGND**
- (2) **UD=VDD and LR=VDD**
- (3) **UD=DGND and LR=DGND**
- (4) **UD=DGND and LR=VDD**

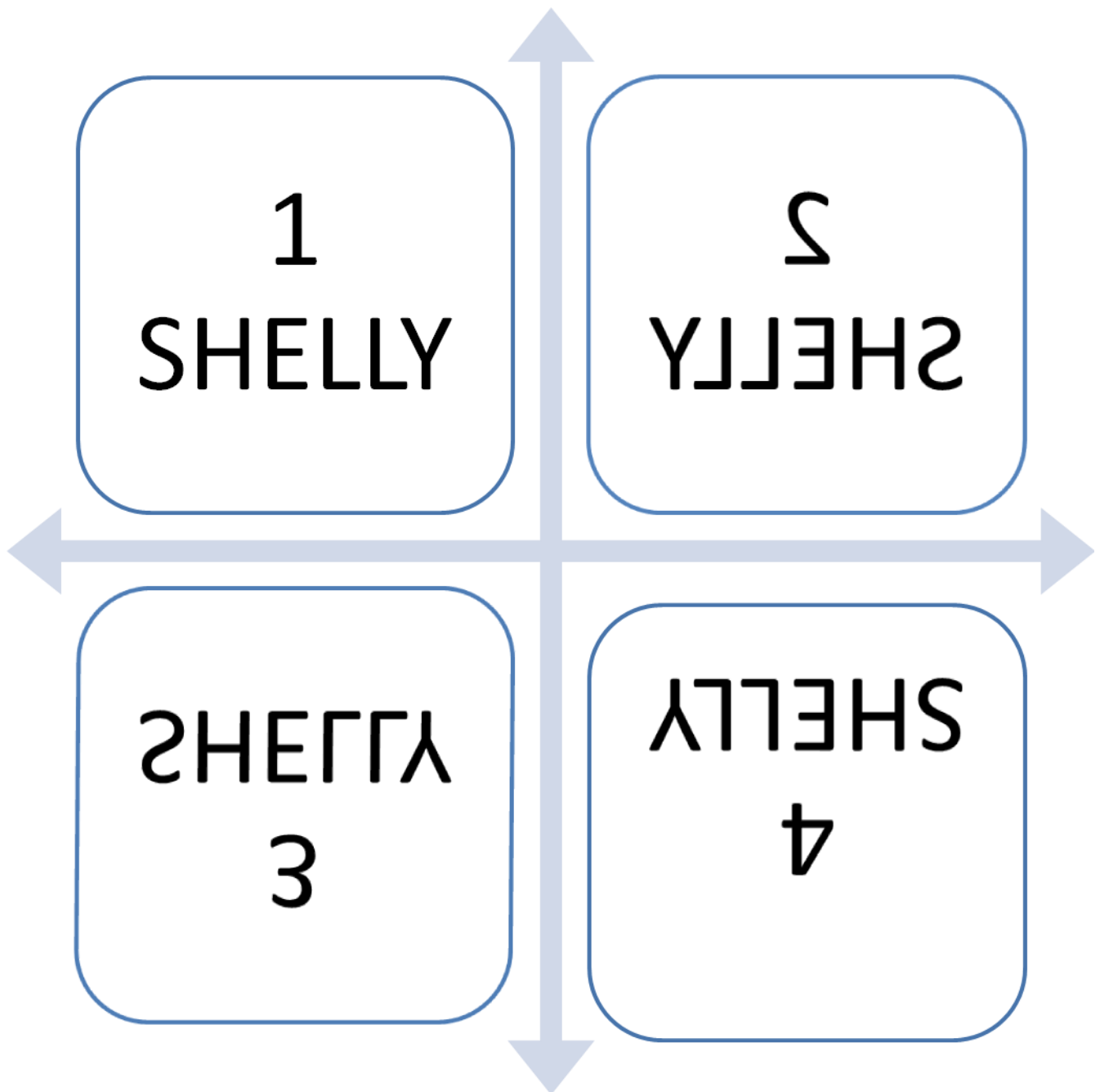

## 10. LED driving conditions

ITEM	SYMBOL	MIN	TYP	MAX	UNIT	REMARK
Peak forward current	$I_P$	-	-	210	mA	-
Maximum reverse voltage	$V_R$	-	-	15	V	-
Applied forward voltage	$V_{AK}$	-	23.1	24.5	V	-
Applied forward current	$I_{AK}$	-	60	-	mA	-
LED power consumption	PF	-	1.4	-	W	-
LED life time	LL	-	25000	-	Hrs	at $I_{AK}=60\text{mA}$ (*1)

(\*1) LED life time is defined as follow: The final brightness is at 50% of original brightness.

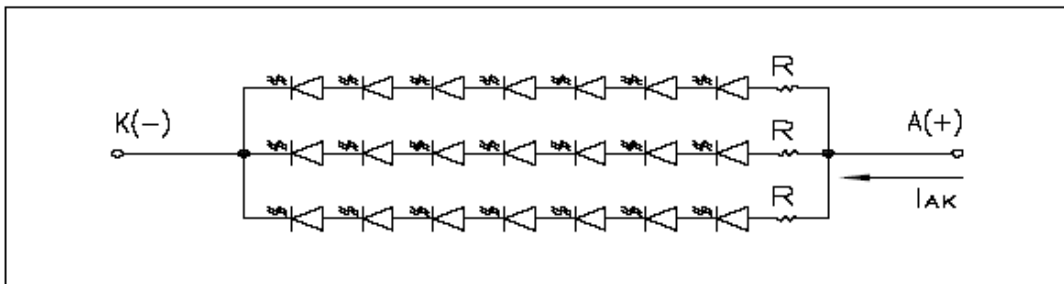

## 11. Timing Characteristics

**Please consult the spec of SSD1963**

## **12. Touch panel Information**

PIN OUT	
1	X1
2	Y1
3	X2
4	Y2

PIN1-PIN3	200ohm-900ohm
PIN2-PIN4	200ohm-900ohm

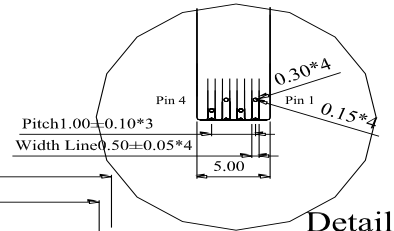
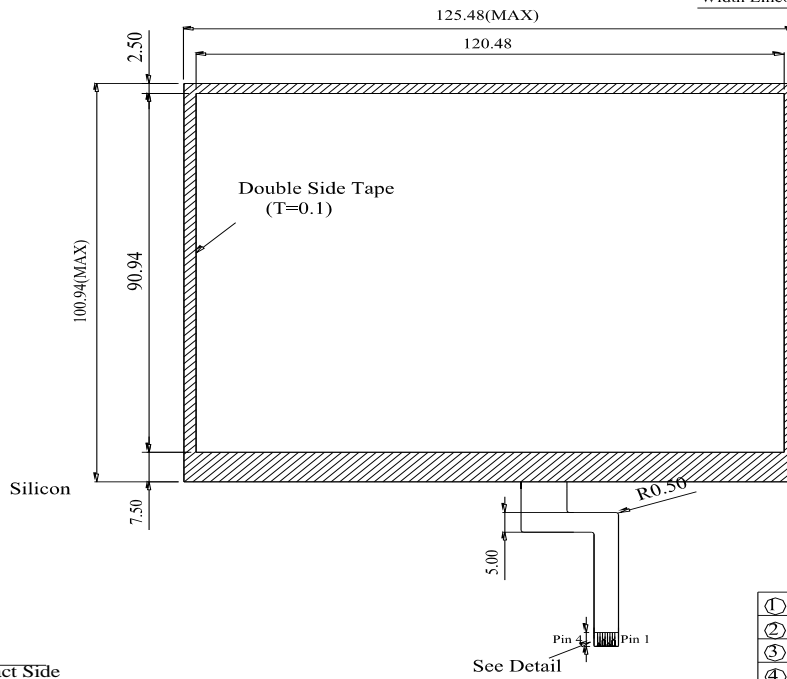
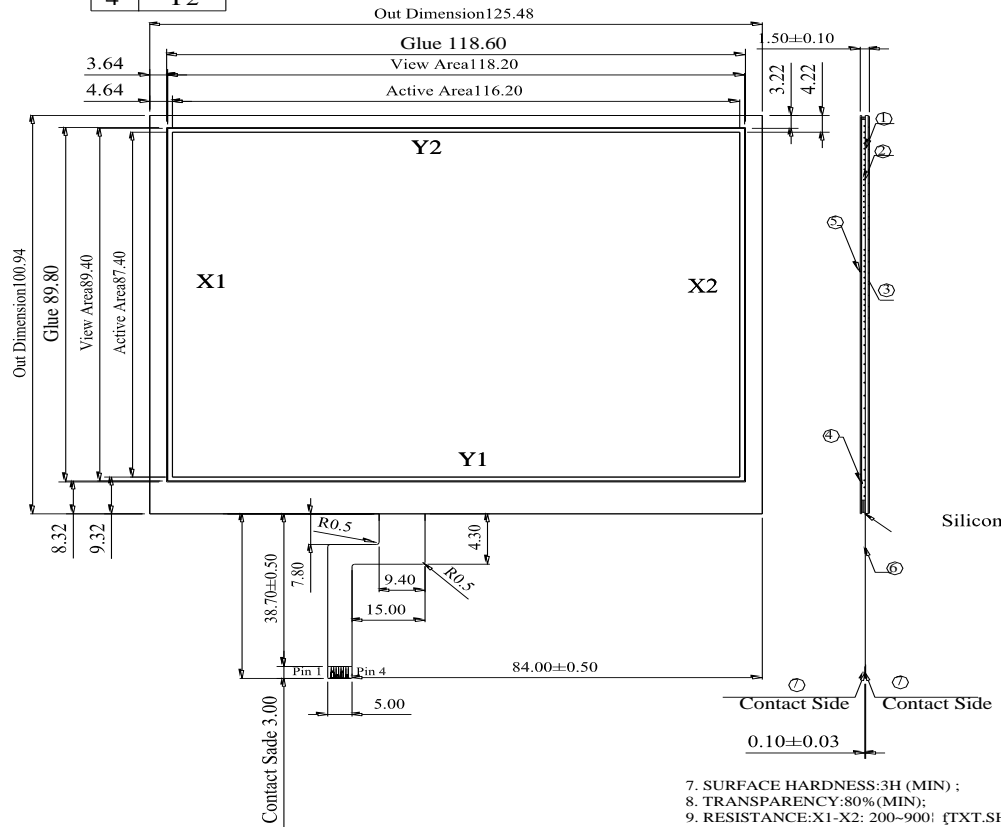

Detail  
3:1

①	1.10mm ITO Glass
②	Spacer DOT
③	Double-faced adhesive
④	Adhesive
⑤	0.188mm ITO Film/Anti Glare
⑥	FPC Tail
⑦	Contact Side

- NOTES:
- TOUCH PANEL TYPE: ANALOG RESISTANCE, 4 LINES;
  - FILM MATERIAL: SINGLE-LAYER FILM WITH ANTI-GLARE;
  - OPERATION VOLTAGE: DC 7V(MAX);
  - INPUT MODE: PEN OR FINGER, 80g(MIN);
  - LINEARITY: 1.5% MAX;
  - RESPONSE TIME: 10ms(MAX);

- SURFACE HARDNESS: 3H (MIN) ;
- TRANSPARENCY: 80% (MIN);
- RESISTANCE: X1-X2: 200-900! fT.XT.SHX;;  
Y1-Y2: 200-900! fT.XT.SHX;;
- INSURANCE RESISTANCE: 20M! XT.SHX;MIN. (DC 25V);
- LIFE TIME: 1000000 TIMES(MIN);
- OPERATION TEMPERATURE: -20; 30; P STORAGE TEMPERATURE: -30; 80; P13. UNMARKED TOLERANCE: ± Å2;
- REFERENCE DIMENSION: ( ) ;
- REQUIREMENTS ON ENVIRONMENTAL PROTECTION: ROHS.

# 13. Reliability

Environmental Test			
Test Item	Content of Test	Test Condition	Note
High Temperature storage	Endurance test applying the high storage temperature for a long time.	80°C 200hrs	2
Low Temperature storage	Endurance test applying the high storage temperature for a long time.	-30°C 200hrs	1,2
High Temperature Operation	Endurance test applying the electric stress (Voltage & Current) and the thermal stress to the element for a long time.	70°C 200hrs	—
Low Temperature Operation	Endurance test applying the electric stress under low temperature for a long time.	-20°C 200hrs	1
High Temperature/ Humidity Operation	The module should be allowed to stand at 60°C, 90%RH max For 96hrs under no-load condition excluding the polarizer, Then taking it out and drying it at normal temperature.	60°C, 90%RH 96hrs	1,2
Thermal shock resistance	The sample should be allowed stand the following 10 cycles of operation -20°C    25°C    70°C  30min ← 5min → 30min ↑ cycle	-20°C/70°C 10 cycles	—
Vibration test	Endurance test applying the vibration during transportation and using.	Total fixed amplitude : 15mm Vibration Frequency : 10~55Hz One cycle 60 seconds to 3 directions of X,Y,Z for Each 15 minutes	3
Static electricity test	Endurance test applying the electric stress to the terminal.	VS=800V, RS=1.5kΩ CS=100pF 1 time	—

## Content of Reliability Test (wide temperature, -20°C~70°C)

**Note1: No dew condensation to be observed.**

**Note2: The function test shall be conducted after 4 hours storage at the normal**

Temperature and humidity after remove from the test chamber.

Note3: Vibration test will be conducted to the product itself without putting it in a container.

## 14. Inspection specification

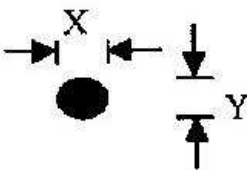
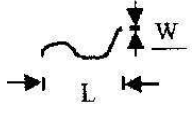
NO	Item	Criterion	AQL											
01	Electrical Testing	1.1 Missing vertical, horizontal segment, segment contrast defect. 1.2 Missing character, dot or icon. 1.3 Display malfunction. 1.4 No function or no display. 1.5 Current consumption exceeds product specifications. 1.6 LCD viewing angle defect. 1.7 Mixed product types. 1.8 Contrast defect.	0.65											
02	Black or white spots on LCD (display only)	2.1 White and black spots on display $\leq 0.25\text{mm}$ , no more than three white or black spots present. 2.2 Densely spaced: No more than two spots or lines within 3mm	2.5											
03	LCD black spots, white spots, contamination (non-display)	3.1 Round type : As following drawing $\Phi = (x + y) / 2$  <table border="1" data-bbox="874 1064 1353 1460"> <thead> <tr> <th>SIZE</th> <th>Acceptable Q TY</th> </tr> </thead> <tbody> <tr> <td><math>\Phi \leq 0.10</math></td> <td>Accept no dense</td> </tr> <tr> <td><math>0.10 &lt; \Phi \leq 0.20</math></td> <td>2</td> </tr> <tr> <td><math>0.20 &lt; \Phi \leq 0.25</math></td> <td>1</td> </tr> <tr> <td><math>0.25 &lt; \Phi</math></td> <td>0</td> </tr> </tbody> </table>	SIZE	Acceptable Q TY	$\Phi \leq 0.10$	Accept no dense	$0.10 < \Phi \leq 0.20$	2	$0.20 < \Phi \leq 0.25$	1	$0.25 < \Phi$	0	2.5	
		SIZE	Acceptable Q TY											
$\Phi \leq 0.10$	Accept no dense													
$0.10 < \Phi \leq 0.20$	2													
$0.20 < \Phi \leq 0.25$	1													
$0.25 < \Phi$	0													
3.2 Line type : (As following drawing)  <table border="1" data-bbox="710 1500 1353 1769"> <thead> <tr> <th>Length</th> <th>Width</th> <th>Acceptable Q TY</th> </tr> </thead> <tbody> <tr> <td>---</td> <td><math>W \leq 0.02</math></td> <td>Accept no dense</td> </tr> <tr> <td><math>L \leq 3.0</math></td> <td><math>0.02 &lt; W \leq 0.03</math></td> <td rowspan="2">2</td> </tr> <tr> <td><math>L \leq 2.5</math></td> <td><math>0.03 &lt; W \leq 0.05</math></td> </tr> <tr> <td>---</td> <td><math>0.05 &lt; W</math></td> <td>As round type</td> </tr> </tbody> </table>	Length	Width	Acceptable Q TY	---	$W \leq 0.02$	Accept no dense	$L \leq 3.0$	$0.02 < W \leq 0.03$	2	$L \leq 2.5$	$0.03 < W \leq 0.05$	---	$0.05 < W$	As round type
Length	Width	Acceptable Q TY												
---	$W \leq 0.02$	Accept no dense												
$L \leq 3.0$	$0.02 < W \leq 0.03$	2												
$L \leq 2.5$	$0.03 < W \leq 0.05$													
---	$0.05 < W$	As round type												
04	Polarizer bubbles	<table border="1" data-bbox="842 1809 1353 2033"> <thead> <tr> <th>Size <math>\Phi</math></th> <th>Acceptable Q TY</th> </tr> </thead> <tbody> <tr> <td><math>\Phi \leq 0.20</math></td> <td>Accept no dense</td> </tr> <tr> <td><math>0.20 &lt; \Phi \leq 0.50</math></td> <td>3</td> </tr> <tr> <td><math>0.50 &lt; \Phi \leq 1.00</math></td> <td>2</td> </tr> </tbody> </table>	Size $\Phi$	Acceptable Q TY	$\Phi \leq 0.20$	Accept no dense	$0.20 < \Phi \leq 0.50$	3	$0.50 < \Phi \leq 1.00$	2	2.5			
Size $\Phi$	Acceptable Q TY													
$\Phi \leq 0.20$	Accept no dense													
$0.20 < \Phi \leq 0.50$	3													
$0.50 < \Phi \leq 1.00$	2													

		If bubbles are visible, judge using black spot specifications, not easy to find, must check in specify direction.	$1.00 < \Phi$	0
			Total Q TY	3

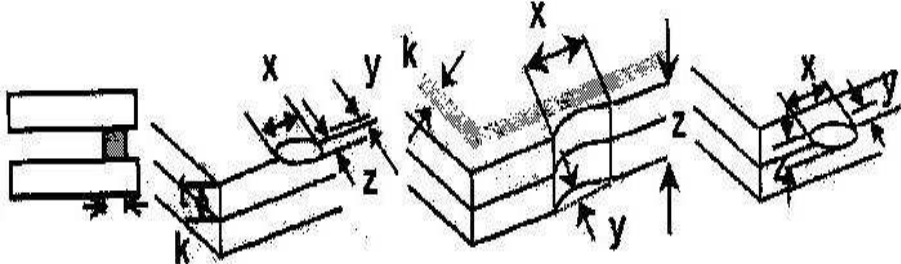
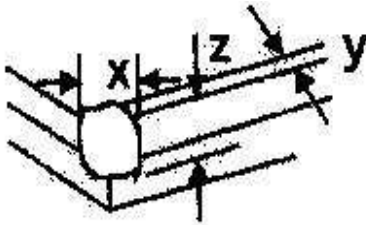
NO	Item	Criterion	AQL																		
05	Scratches	Follow NO.3 LCD black spots, white spots, contamination																			
06	Chipped glass	<p>Symbols Define:  x: Chip length      y: Chip width      z: Chip thickness  k: Seal width      t: Glass thickness      a: LCD side length  L: Electrode pad length:</p> <p>6.1 General glass chip :  6.1.1 Chip on panel surface and crack between panels:</p>  <table border="1" data-bbox="443 996 1348 1220"> <thead> <tr> <th>z: Chip thickness</th> <th>y: Chip width</th> <th>x: Chip length</th> </tr> </thead> <tbody> <tr> <td><math>Z \leq 1/2t</math></td> <td>Not over viewing area</td> <td><math>x \leq 1/8a</math></td> </tr> <tr> <td><math>1/2t &lt; z \leq 2t</math></td> <td>Not exceed 1/3k</td> <td><math>x \leq 1/8a</math></td> </tr> </tbody> </table> <p>⊙If there are 2 or more chips, x is total length of each chip.</p> <p>6.1.2 Corner crack:</p>  <table border="1" data-bbox="443 1668 1348 1892"> <thead> <tr> <th>z: Chip thickness</th> <th>y: Chip width</th> <th>x: Chip length</th> </tr> </thead> <tbody> <tr> <td><math>Z \leq 1/2t</math></td> <td>Not over viewing area</td> <td><math>x \leq 1/8a</math></td> </tr> <tr> <td><math>1/2t &lt; z \leq 2t</math></td> <td>Not exceed 1/3k</td> <td><math>x \leq 1/8a</math></td> </tr> </tbody> </table> <p>⊙If there are 2 or more chips, x is the total length of each chip.</p>	z: Chip thickness	y: Chip width	x: Chip length	$Z \leq 1/2t$	Not over viewing area	$x \leq 1/8a$	$1/2t < z \leq 2t$	Not exceed 1/3k	$x \leq 1/8a$	z: Chip thickness	y: Chip width	x: Chip length	$Z \leq 1/2t$	Not over viewing area	$x \leq 1/8a$	$1/2t < z \leq 2t$	Not exceed 1/3k	$x \leq 1/8a$	2.5
z: Chip thickness	y: Chip width	x: Chip length																			
$Z \leq 1/2t$	Not over viewing area	$x \leq 1/8a$																			
$1/2t < z \leq 2t$	Not exceed 1/3k	$x \leq 1/8a$																			
z: Chip thickness	y: Chip width	x: Chip length																			
$Z \leq 1/2t$	Not over viewing area	$x \leq 1/8a$																			
$1/2t < z \leq 2t$	Not exceed 1/3k	$x \leq 1/8a$																			

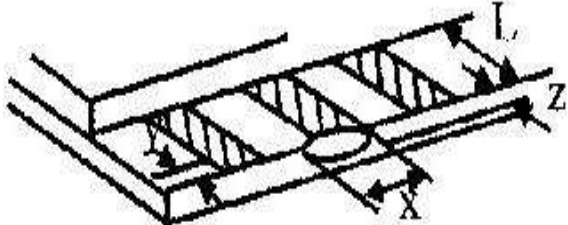
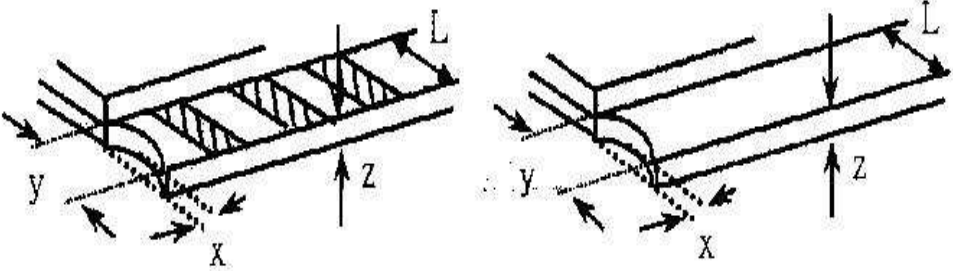
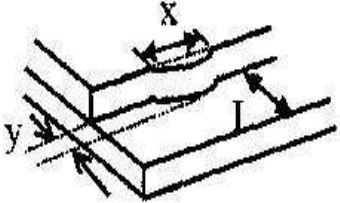
O	Item	Criterion	AQL																
06	Glass crack	<p>Symbols :</p> <p>x: Chip length      y: Chip width      z: Chip thickness  k: Seal width      t: Glass thickness      a: LCD side length  L: Electrode pad length</p> <p>6.2 Protrusion over terminal :</p> <p>6.2.1 Chip on electrode pad :</p>  <table border="1" data-bbox="352 719 1264 835"> <tr> <td>y: Chip width</td> <td>x: Chip length</td> <td>z: Chip thickness</td> </tr> <tr> <td><math>y \leq 0.5\text{mm}</math></td> <td><math>x \leq 1/8a</math></td> <td><math>0 &lt; z \leq t</math></td> </tr> </table> <p>6.2.2 Non-conductive portion:</p>  <table border="1" data-bbox="424 1182 1264 1352"> <tr> <td>y: Chip width</td> <td>x: Chip length</td> <td>z: Chip thickness</td> </tr> <tr> <td><math>y \leq L</math></td> <td><math>x \leq 1/8a</math></td> <td><math>0 &lt; z \leq t</math></td> </tr> </table> <p>○If the chipped area touches the ITO terminal, over 2/3 of the ITO must remain and be inspected according to electrode terminal specifications.</p> <p>○If the product will be heat sealed by the customer, the alignment mark not be damaged.</p> <p>6.2.3 Substrate protuberance and internal crack.</p>  <table border="1" data-bbox="762 1704 1270 1821"> <tr> <td>y: width</td> <td>x: length</td> </tr> <tr> <td><math>y \leq 1/3L</math></td> <td><math>x \leq a</math></td> </tr> </table>	y: Chip width	x: Chip length	z: Chip thickness	$y \leq 0.5\text{mm}$	$x \leq 1/8a$	$0 < z \leq t$	y: Chip width	x: Chip length	z: Chip thickness	$y \leq L$	$x \leq 1/8a$	$0 < z \leq t$	y: width	x: length	$y \leq 1/3L$	$x \leq a$	2.5
y: Chip width	x: Chip length	z: Chip thickness																	
$y \leq 0.5\text{mm}$	$x \leq 1/8a$	$0 < z \leq t$																	
y: Chip width	x: Chip length	z: Chip thickness																	
$y \leq L$	$x \leq 1/8a$	$0 < z \leq t$																	
y: width	x: length																		
$y \leq 1/3L$	$x \leq a$																		

NO	Item	Criterion	AQL
07	Cracked glass	The LCD with extensive crack is not acceptable.	2.5
08	Backlight elements	8.1 Illumination source flickers when lit. 8.2 Spots or scratched that appear when lit must be judged. Using LCD spot, lines and contamination standards. 8.3 Backlight doesn't light or color wrong.	0.65 2.5 0.65
09	Bezel	9.1 Bezel may not have rust, be deformed or have fingerprints, stains or other contamination. 9.2 Bezel must comply with job specifications.	2.5 0.65
10	PCB、COB	10.1 COB seal may not have pinholes larger than 0.2mm or contamination. 10.2 COB seal surface may not have pinholes through to the IC. 10.3 The height of the COB should not exceed the height indicated in the assembly diagram. 10.4 There may not be more than 2mm of sealant outside the seal area on the PCB. And there should be no more than three places. 10.5 No oxidation or contamination PCB terminals. 10.6 Parts on PCB must be the same as on the production characteristic chart. There should be no wrong parts, missing parts or excess parts. 10.7 The jumper on the PCB should conform to the product characteristic chart. 10.8 If solder gets on bezel tab pads, LED pad, zebra pad or screw hold pad, make sure it is smoothed down.	2.5 2.5 0.65 2.5 2.5 0.65 2.5
11	Soldering	11.1 No un-melted solder paste may be present on the PCB. 11.2 No cold solder joints, missing solder connections, oxidation or icicle. 11.3 No residue or solder balls on PCB. 11.4 No short circuits in components on PCB.	2.5 2.5 2.5 0.65

NO	Item	Criterion	AQL
12	General appearance	<p>12.1 No oxidation, contamination, curves or, bends on interface Pin (OLB) of TCP.</p> <p>12.2 No cracks on interface pin (OLB) of TCP.</p> <p>12.3 No contamination, solder residue or solder balls on product.</p> <p>12.4 The IC on the TCP may not be damaged, circuits.</p> <p>12.5 The uppermost edge of the protective strip on the interface pin must be present or look as if it cause the interface pin to sever.</p> <p>12.6 The residual rosin or tin oil of soldering (component or chip component) is not burned into brown or black color.</p> <p>12.7 Sealant on top of the ITO circuit has not hardened.</p> <p>12.8 Pin type must match type in specification sheet.</p> <p>12.9 LCD pin loose or missing pins.</p> <p>12.10 Product packaging must the same as specified on packaging specification sheet.</p> <p>12.11 Product dimension and structure must conform to product specification sheet.</p>	<p>2.5</p> <p>0.65</p> <p>2.5</p> <p>2.5</p> <p>2.5</p> <p>2.5</p> <p>2.5</p> <p>0.65</p> <p>0.65</p> <p>0.65</p> <p>0.65</p>



**INNOVATIVE DISPLAY TECHNOLOGIES**

**17171 MURPHY AVENUE**

**IRVINE, CALIFORNIA 92614-5915**

**P: 949-417-8070/F: 949-417-8075**

**SCA05736-TFA-LRC**

**Sales signature :** \_\_\_\_\_

**Customer Signature :** \_\_\_\_\_

**Date :**     /     /     \_\_\_\_\_