

Features



- Built-in PHY supporting SGMII Interface
- Built-in high performance MCU supporting easier configuration
- Dual data-rate of 100BASE-LX/1000BASE-LX operation
- 1310nm FP laser and PIN photo-detector
- Up to 10km transmission with SMF
- Standard serial ID information Compatible with SFP MSA
- SFP MSA package with duplex LC connector
- With Spring-Latch for high density application
- +3.3V single power supply
- Operating case temperature: -40 to +85°C
Commercial temperature: -5 to +70°C

Regulatory Compliance

Table 1 - Regulatory Compliance

Feature	Standard	Performance
Electrostatic Discharge (ESD) to the Electrical Pins	MIL-STD-883E Method 3015.7	Class 1
Electrostatic Discharge (ESD) to the Duplex LC Receptacle	IEC 61000-4-2	Compliant with standards
Electromagnetic Interference (EMI)	FCC Part 15 Class B	Compliant with standards
Laser Eye Safety	FDA 21CFR 1040.10 and 1040.11 EN (IEC) 60825-1,2	Compliant with Class I laser product.
RoHS	2011/65/EU	Compliant with RoHS

Absolute Maximum Ratings

Table 2 - Absolute Maximum Ratings

Parameter	Symbol	Min.	Typical	Max.	Unit	Notes
Storage Temperature	T _s	-40	-	+85	°C	
Supply Voltage	V _{CC}	-0.5	-	+3.6	V	
Operating Relative Humidity	RH	5	-	+95	%	

Recommended Operating Conditions

Table 3 – Recommended Operating Conditions

Parameter		Symbol	Min.	Typical	Max.	Unit	Notes
Operating Case Temperature	C-temp	T_C	-5	-	+70	°C	
	I-temp		-40		+85	°C	
Power Supply Voltage		V_{CC}	3.13	3.3	3.47	V	
Power Supply Current		I_{CC}	-	-	350	mA	1
Power Dissipation		P_D	-	-	1.5	W	
Data Rate	1000BASE-LX			1250		Mbps	
	100BASE-FX			125			

Note 1: The max power supply current after module work stable.

Optical Characteristics

Table 4 – Optical Characteristics

Transmitter								
Parameter		Symbol	Min.	Typical	Max.	Unit	Notes	
Centre Wavelength		λ_C	1260	1310	1360	nm		
Average Output Power	1000BASE-LX	P_{Out}	-9.5		-3	dBm	1	
	100BASE-LX	P_{Out}	-15		-8		1	
$P_{Out}@TX$ Disable Asserted		P_{Out}			-45	dBm	1	
Spectral Width (RMS)	1000BASE-LX	σ			4	nm		
	100BASE-LX				7.7			
Extinction Ratio		EX	9			dB		
Rise/Fall Time (20%~80%)	1000BASE-LX	t_r/t_f			0.26	ns	2	
	100BASE-LX				3			
Total Jitter at TP2	1000BASE-LX	J_T			0.481	UI	3	
	100BASE-LX				0.4			
Deterministic Jitter at TP2	1000BASE-LX	J_D			0.250		3	
	100BASE-LX				0.305			
Output Optical Eye		Compatible with IEEE 802.3ah-2004						4
Receiver								
Centre Wavelength		λ_C	1260	1310	1570	nm		
Receiver Sensitivity	1000BASE-LX				-22	dBm	5	
	100BASE-LX				-28		6	

Receiver	1000BASE-LX		-3			dBm	5
Overload	100BASE-LX		-8				6
Return Loss			12			dB	
LOS De-Assert	1000BASE-LX	LOS _D			-23	dBm	
	100BASE-LX				-23		
LOS Assert	1000BASE-LX	LOS _A	-45			dBm	
	100BASE-LX		-45				
LOS Hysteresis			0.5		4.5	dB	
Total Jitter at TP4	SGMII	J _T			0.749	UI	3
Deterministic Jitter at TP4	SGMII	J _D			0.462	UI	

Notes:

1. The optical power is launched into 9/125um SMF.
2. Unfiltered, measured with 8B/10B code for 1.25Gbps and 4B/5B code for 125Mbps
3. Meet the specified maximum output jitter requirements if the specified maximum input jitter is present.
4. Measured with 8B/10B code for 1.25Gbps and 4B/5B code for 125Mbps.
5. Measured with 8B/10B code for 1.25Gbps, worst-case extinction ratio, and BER $\leq 1 \times 10^{-12}$.
6. Measured with 4B/5B code for 125Mbps, worst-case extinction ratio, and BER $\leq 1 \times 10^{-12}$.

Electrical Characteristics

Table 5 – Electrical Characteristics

Transmitter						
Parameter	Symbol	Min.	Typical	Max.	Unit	Notes
Data Input Swing Differential (SGMII Series interface)	V _{IN}	500		2400	mV	1
Input Differential Impedance	Z _{IN}	80	100	120	Ω	
TX Disable	Disable		2.0	V _{cc}	V	
	Enable		V _{ee}	V _{ee} +0.8		
TX Fault	Fault		2.0	V _{cc}	V	
	Normal		V _{ee}	V _{ee} +0.5		
Receiver						
Data Output Swing Differential (SGMII Series Interface)	V _{OUT}	370		2000	mV	1
LOS	High		2.0	V _{cc} +0.3	V	
	Low		V _{ee}	V _{ee} +0.5		

Notes:

1. PECL logic, internally AC coupled.

Recommended Host Board Power Supply Circuit

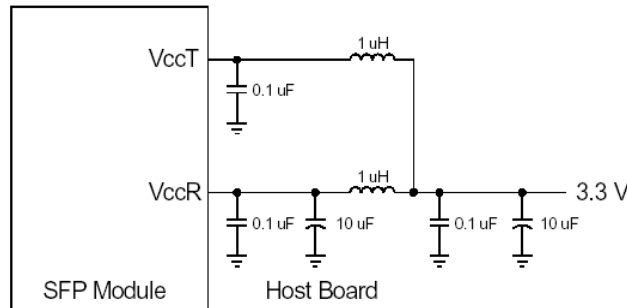

Figure 1, Recommended Host Board Power Supply Circuit

Recommended Interface Circuit

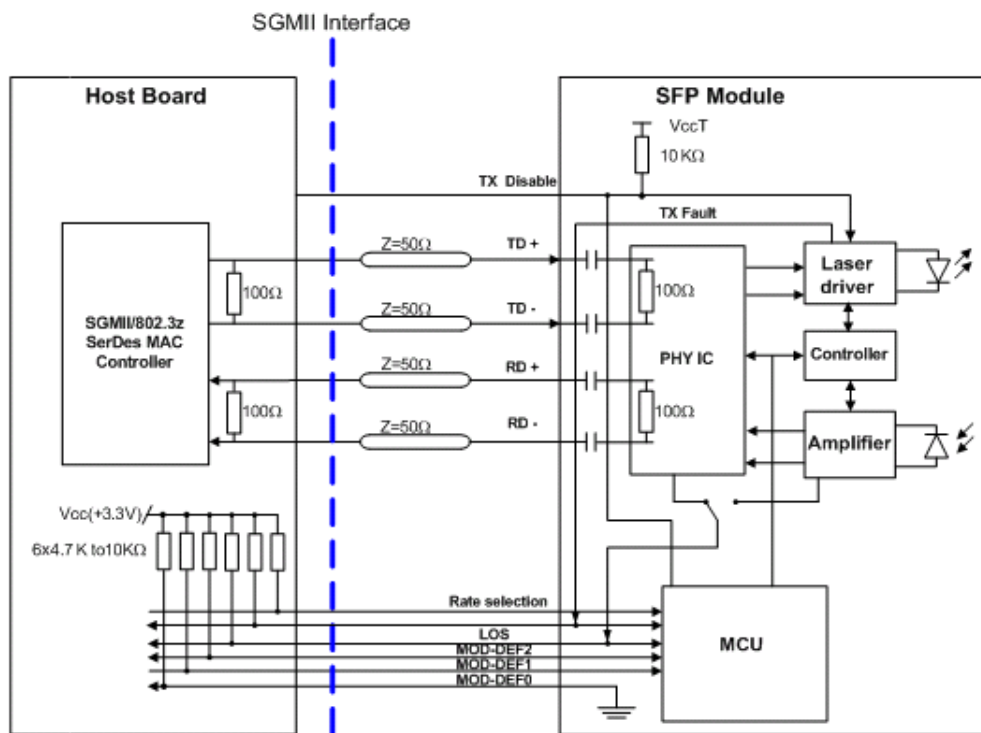

Figure 2, Recommended Interface Circuit

Pin Definitions

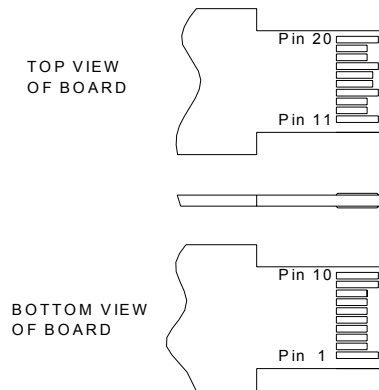

Figure 3, Pin View

Table 6–Pin Function Definitions

Pin No.	Name	Function	Plug Seq.	Notes
1	VeeT	Transmitter Ground	1	
2	TX Fault	Transmitter Fault Indication	3	Note 1
3	TX Disable	Transmitter Disable	3	Note 2
4	MOD-DEF2	Module Definition 2	3	Note 3
5	MOD-DEF1	Module Definition 1	3	Note 3
6	MOD-DEF0	Module Definition 0	3	Note 3
7	Rate Select	Not Use	3	
8	LOS	Loss of Signal	3	Note 4
9	VeeR	Receiver Ground	1	
10	VeeR	Receiver Ground	1	
11	VeeR	Receiver Ground	1	
12	RD-	Inv. Received Data Out	3	Note 5
13	RD+	Received Data Out	3	Note 5
14	VeeR	Receiver Ground	1	
15	VccR	Receiver Power	2	
16	VccT	Transmitter Power	2	
17	VeeT	Transmitter Ground	1	
18	TD+	Transmit Data In	3	Note 6
19	TD-	Inv. Transmit Data In	3	Note 6
20	VeeT	Transmitter Ground	1	

Notes:

1. TX Fault is an open collector output, which should be pulled up with a 4.7k~10kΩ resistor on the host board to a voltage between 2.0V and Vcc+0.3V. Logic 0 indicates normal operation; logic 1 indicates a laser fault of some kind. In the low state, the output will be pulled to less than 0.8V.
2. TX Disable is an input that is used to shut down the transmitter optical output. It is pulled up within the

module with a 4.7k~10kΩ resistor. Its states are:

Low (0~0.8V):	Transmitter on
(>0.8V, <2.0V):	Undefined
High (2.0~3.465V):	Transmitter Disabled
Open:	Transmitter Disabled

- MOD-DEF 0,1,2 are the module definition pins. They should be pulled up with a 4.7k~10kΩ resistor on the host board. The pull-up voltage shall be VccT or VccR.
 MOD-DEF 0 is grounded by the module to indicate that the module is present
 MOD-DEF 1 is the clock line of two wire serial interface for serial ID
 MOD-DEF 2 is the data line of two wire serial interface for serial ID
- LOS is an open collector output, which should be pulled up with a 4.7k~10kΩ resistor on the host board to a voltage between 2.0V and Vcc+0.3V. Logic 0 indicates normal operation; logic 1 indicates loss of signal or link down with partner I. In the low state, the output will be pulled to less than 0.8V.
- These are the differential receiver output. They are internally AC-coupled 100Ω differential lines which should be terminated with 100Ω (differential) at host with SGMII interface.
- These are the differential transmitter inputs. They are AC-coupled, differential lines with 100Ω differential termination inside the module.

EEPROM Information

The SFP MSA defines a 256-byte memory map in EEPROM describing the transceiver's capabilities, standard interfaces, manufacturer, and other information, which is accessible over a 2 wire serial interface at the 8-bit address 1010000X (A0h). The memory contents refer to Table 7.

Table 7 –EEPROM Serial ID Memory Contents (A0h)

Addr.	Field Size (Bytes)	Name of Field	Hex	Description
0	1	Identifier	03	SFP
1	1	Ext. Identifier	04	MOD4
2	1	Connector	07	LC
3—10	8	Transceiver	00 00 00 12 00 00 00 00	100BASE-LX/LX10/1000BASE-LX
11	1	Encoding	01	8B10B
12	1	BR, nominal	0D	1.25GHz
13	1	Reserved	00	
14	1	Length (9um)-km	0A	10km
15	1	Length (9um)	64	10000m
16	1	Length (50um)	00	
17	1	Length (62.5um)	00	
18	1	Length (copper)	00	
19	1	Reserved	00	
20—35	16	Vendor name	53 4F 55 52 43 45 50 48 4F 54 4F 4E 49 43 53 20	"SOURCEPHOTONICS "(ASC II)

36	1	Reserved	00	
37—39	3	Vendor OUI	00 1F 22	
40—55	16	Vendor PN	53 50 47 44 52 4C 58 xx 44 46 43 20 20 20 20 20	“SPGDRLXxDFC” (ASC II)
56—59	4	Vendor rev	31 30 20 20	ASC II (“31 30 20 20” means 1.0 revision)
60-61	2	Wavelength	05 1E	1310nm
62	1	Reserved	00	
63	1	CC BASE	xx	Check sum of bytes 0 - 62
64—65	2	Options	00 1A	LOS, TX_FAULT and TX_DISABLE
66	1	BR, max	00	
67	1	BR, min	00	
68—83	16	Vendor SN	xx xx xx xx xx xx xx xx xx xx xx xx xx xx xx xx	ASC II .
84—91	8	Vendor date code	xx xx xx xx xx xx xx xx	Year (2 bytes), Month (2 bytes), Day (2 bytes)
92	1	Diagnostic type	68	Diagnostics(Int.Cal)
93	1	Enhanced option	B0	Diagnostics(Optional Alarm/warning flags, Soft TX_FAULT and Soft TX_LOS monitoring)
94	1	SFF-8472	02	Diagnostics(SFF-8472 Rev 9.4)
95	1	CC_EXT	xx	Check sum of bytes 64 - 94
96-255	160	Vendor specific		

Note: The “xx” byte should be filled in according to practical case. For more information, please refer to the related document of SFF-8472 Rev 9.5.

Recommended Software configuration

How to configure auto-negotiation, loopback, work speed

The module can support auto-negotiation, loopback configuration.

Please refer the following steps to configure:

Step 1: Access the module at 0xA2 via two-wire serial interface.

Step 2: Configure 0x6Dh/6Eh(Byte 109~110) as below table. Addr.109 default is “1Fh”. Addr.110 default is “00h”.

Addr. 109	Function	“1”	“0”	Default Value (BIN)
bit7	FEFI Status	FEFI condition detected	FEFI condition not detected	‘0’
bit6	Fiber Auto-Negotiation	Disable	Enable	‘0’
Bit5	MAC Auto-Negotiation	Disable	Enable	‘0’
bit4	FEFI function	Disable	Enable	‘1’

bit3	CRC checker	Disable/Reset	Enable	'1'
bit2	Fiber loop back	Disable	Enable	'1'
bit1	MAC loop back	Disable	Enable	'1'
bit0	Reserved	Reserved	Reserved	'1'

Addr. 110	Function	"1"	"0"	Default Value (BIN)
bit7	TX Disable State	TX-Disable	TX-Enable	'0'
bit6	TX-Disable	TX-Disable	TX-Enable	'0'
Bit5~Bit4	Reserved	Reserved	Reserved	'0'
Bit3	Work speed mode	1000Base	100Base	'0'
Bit2	TX fault output status	TX fault indication	No fault	'0'
Bit1	LOS pin output status	LOS asserted (Link down)	LOS de-asserted (Link up)	'0'
Bit0	Data Ready status	Not ready	Ready	'0'

Monitoring Specification

The digital diagnostic monitoring interface also defines another 256-byte memory map in EEPROM, which makes use of the 8 bit address 1010001X (A2h). Please see Figure 4. For detail EEPROM information, please refer to the related document of SFF-8472 Rev 9.5. The monitoring specification of this product is described in Table 8.

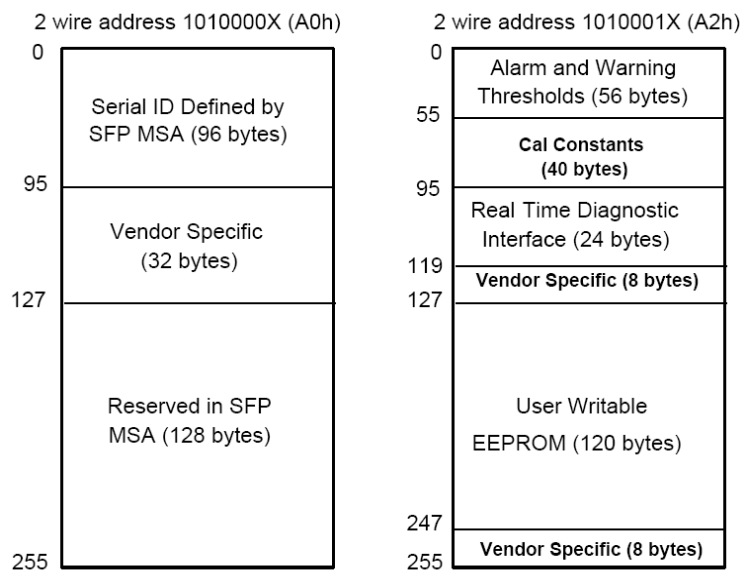

Figure 4, EEPROM Memory Map Specific Data Field Descriptions

Table 8- Monitoring Specification

Parameter		Range	Accuracy	Calibration
Temperature	I-temp	-40 to 95°C	±3°C	Internal
	C-temp	-10 to 80°C	±3°C	Internal
Voltage		2.97 to 3.63V	±3%	Internal
Bias Current		3 to 80mA	±10%	Internal
TX Power(1000Base-LX)		-9.5 to -3 dBm	±3dB	Internal
TX Power(100Base-LX)		-15 to -8 dBm	±3dB	Internal
RX Power(1000Base-LX)		-24 to -3 dBm	±3dB	Internal
RX Power(100Base-LX)		-30 to -8 dBm	±3dB	Internal

Mechanical Diagram

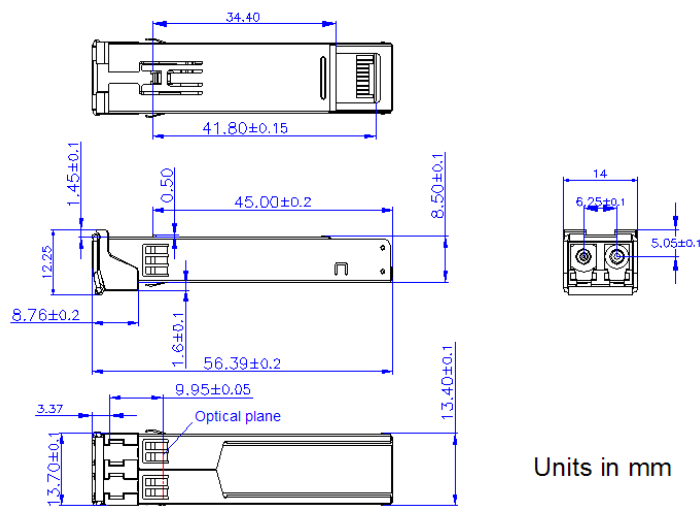

Figure 4, Mechanical Diagram of SFP

Order Information

Table 9 – Order Information

Part No.	Media	Data Rate(Mbps)	Transmission Distance(km)	Temperature
SPG-DR-LX-IDFC	SMF	125/1250	10	-40~+85°C
SPG-DR-LX-CDFC	SMF	125/1250	10	-5~+70°C

Warnings

Handling Precautions: This device is susceptible to damage as a result of electrostatic discharge (ESD). A static free environment is highly recommended. Follow guidelines according to proper ESD procedures.

Laser Safety: Radiation emitted by laser devices can be dangerous to human eyes. Avoid eye exposure to direct or indirect radiation.

Legal Notice

IMPORTANT NOTICE!

All information contained in this document is subject to change without notice, at Source Photonics's sole and absolute discretion. Source Photonics warrants performance of its products to current specifications only in accordance with the company's standard one-year warranty; however, specifications designated as "preliminary" are given to describe components only, and Source Photonics expressly disclaims any and all warranties for said products, including express, implied, and statutory warranties, warranties of merchantability, fitness for a particular purpose, and non-infringement of proprietary rights. Please refer to the company's Terms and Conditions of Sale for further warranty information.

Source Photonics assumes no liability for applications assistance, customer product design, software performance, or infringement of patents, services, or intellectual property described herein. No license, either express or implied, is granted under any patent right, copyright, or intellectual property right, and Source Photonics makes no representations or warranties that the product(s) described herein are free from patent, copyright, or intellectual property rights. Products described in this document are NOT intended for use in implantation or other life support applications where malfunction may result in injury or death to persons. Source Photonics customers using or selling products for use in such applications do so at their own risk and agree to fully defend and indemnify Source Photonics for any damages resulting from such use or sale.

THE INFORMATION CONTAINED IN THIS DOCUMENT IS PROVIDED ON AN "AS IS" BASIS. Customer agrees that Source Photonics is not liable for any actual, consequential, exemplary, or other damages arising directly or indirectly from any use of the information contained in this document. Customer must contact Source Photonics to obtain the latest version of this publication to verify, before placing any order, that the information contained herein is current.

Contact

U.S.A. Headquarters

20550 Nordhoff Street
Chatsworth, CA 91311
USA
Tel: +1-818-773-9044
Fax: +1-818-773-0261

China

Building #2&5, West Export Processing Zone
No. 8 Kexin Road, Hi-Tech Zone
Chengdu, 611731, China
Tel: +86-28-8795-8788
Fax: +86-28-8795-8789

Taiwan

9F, No 81, Shui Lee Rd.
Hsinchu, Taiwan, R.O.C.
Tel: +886-3-5169222
Fax: +886-3-5169213

© Copyright Source Photonics, Inc. 2007~2013

All rights reserved