



Features

- XFP MSA Rev 4.5 compliant
- Support 10GBASE-ER application
- Up to 40km transmission on SMF
- 1550nm EML and PIN receiver
- XFI high speed electrical interface
- 2-wire interface with integrated Digital Diagnostic monitoring
- XFP MSA package with duplex LC connector
- +5V,+3.3V and +1.8V power supplies
- Power consumption less than 3.5 W
- Operating case temperature: -5~+70°C

Regulatory Compliance

Table 1 - Regulatory Compliance

Feature	Standard	Performance
Electrostatic Discharge (ESD) to the Electrical Pins	MIL-STD-883E Method 3015.7	Class 1(>500V for XFI pins, >2000V for other pins.)
Electrostatic Discharge (ESD) to the Duplex LC Receptacle	IEC 61000-4-2 GR-1089-CORE	Compatible with standards
Electromagnetic Interference (EMI)	FCC Part 15 Class B EN55022 Class B (CISPR 22B) VCCI Class B	Compatible with standards
Immunity	IEC 61000-4-3	Compatible with standards
Laser Eye Safety	FDA 21CFR 1040.10 and 1040.11 EN60950, EN (IEC) 60825-1,2	Compatible with Class I laser product.
RoHS	2002/95/EC 4.1&4.2 2005/747/EC	Compliant with standards ^{note}

Note:

In light of item 5 in Annex of 2002/95/EC, "Pb in the glass of cathode ray tubes, electronic components and fluorescent tubes." and item 13 in Annex of 2005/747/EC, "Lead and cadmium in optical and filter glass.", the two exemptions are being concerned for Source Photonics transceivers, because Source Photonics transceivers use glass, which may contain Pb, for components such as lenses, windows, isolators, and other electronic components.

Absolute Maximum Ratings

Table 2 - Absolute Maximum Ratings

Parameter	Symbol	Min.	Typical	Max.	Unit	Notes
Storage Temperature	T_S	-40	-	+85	°C	
Supply Voltage	V_{CC5}	-0.5	-	+6.0	V	
	V_{CC3}	-0.5	-	+4.0	V	
	V_{CC2}	-0.5	-	+2.0	V	
Operating Relative Humidity	RH	-	-	+85	%	

Recommended Operating Conditions

Table 3 – Recommended Operating Conditions

Parameter	Symbol	Min.	Typical	Max.	Unit	Notes
Operating Case Temperature	T_C	-5	-	+70	°C	
Power Supply Voltage	V_{CC5}	4.75	5.0	5.25	V	
	V_{CC3}	3.14	3.3	3.46	V	
	V_{CC2}	1.71	1.8	1.89	V	
Power Supply Current	I_{CC5}	-	-	500	mA	
	I_{CC3}	-	-	750	mA	
	I_{CC2}	-	-	1000	mA	
Power Dissipation	P_D	-	-	3.5	W	3
Bit Rate	BR	-	10.3125	-	Gbps	
Transmission Distance	TD	2	-	40,000	m	1

Note 1: Measured with G.652 SMF.

Optical Characteristics

Table 4 – Optical Characteristics

Transmitter						
Parameter	Symbol	Min.	Typical	Max.	Unit	Notes
Center Wavelength Range	λ_C	1530	-	1565	nm	
Average Output Power	P_{OUT}	-4.7	-	4.0	dBm	1
Optical Modulation Amplitude	OMA	-1.7	-	-	dBm	1
Average Output Power (Laser Off)	$P_{OUT-OFF}$	-	-	-30	dBm	1
Side Mode Suppression Ratio	SMSR	30	-	-	dB	
Extinction Ratio	ER	3.0	-	-	dB	2
Transmitter and Dispersion Penalty	TDP	-	-	3.0	dB	2

Optical Return Loss Tolerance	ORLT	-	-	21	dB	
Optical Eye Mask	Compliant with IEEE 802.3-2005					2
Receiver						
Center Wavelength Range	λ_C	1530	-	1565	nm	
Receiver Sensitivity	$P_{IN-SENS}$	-	-	-15.8	dBm	3
Receiver Sensitivity in OMA	$P_{IN-SENS(OMA)}$	-	-	-14.1	dBm	3
Receiver Overload	P_{IN-OL}	-1.0	-	-	dBm	3
Receiver Reflectance	Ref	-	-	-26	dB	
LOS Assert	LOS_A	-25	-		dBm	
LOS Deassert	LOS_D	-	-	-17	dBm	
LOS Hysteresis	LOS_H	0.5	-	4	dB	

Notes:

1. The optical power is launched into SMF.
2. Measured with a PRBS $2^{31}-1$ test pattern @10.3125Gbps.
3. Measured with a PRBS $2^{31}-1$ test pattern @10.3125Gbps, $BER \leq 10^{-12}$.

Electrical Characteristics

Table 5 – Electrical Characteristics

Transmitter						
Parameter	Symbol	Min.	Typical	Max.	Unit	Notes
Differential Data Input Amplitude	$V_{IN,P-P}$	120	-	820	mVpp	
Input Differential Impedance	Z_{IN}	85	100	115	Ω	
Tx_Disable, P_Down/RST	V_{IL}	-0.3	-	0.8	V	
	V_{IH}	2.0	-	$V_{CC}+0.3$	V	
Receiver						
Differential Date Output Amplitude	$V_{OUT,P-P}$	340	-	850	mVpp	
Output Differential Impedance	Z_d	80	100	120	Ω	
Output Rise Time, 20%~80%	T_R	24	-	-	ps	
Output Fall Time, 20%~80%	T_F	24	-	-	ps	
Rx_LOS, Mod_NR, Interrupt	V_{OL}	0	-	0.4	V	
	V_{OH}	$V_{CC}-0.5$	-	$V_{CC}+0.3$	V	

Recommended Host Board Power Supply Circuit

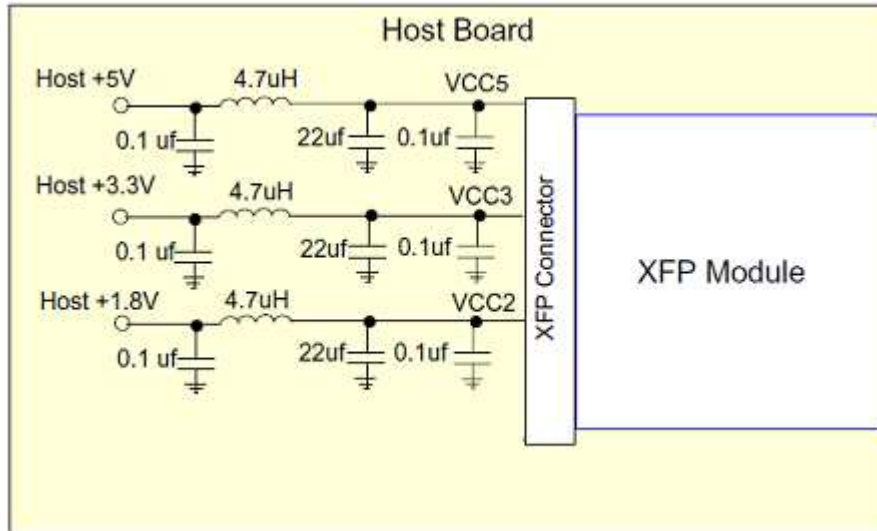

Figure 1, Recommended Host Board Power Supply Circuit

Recommended Interface Circuit

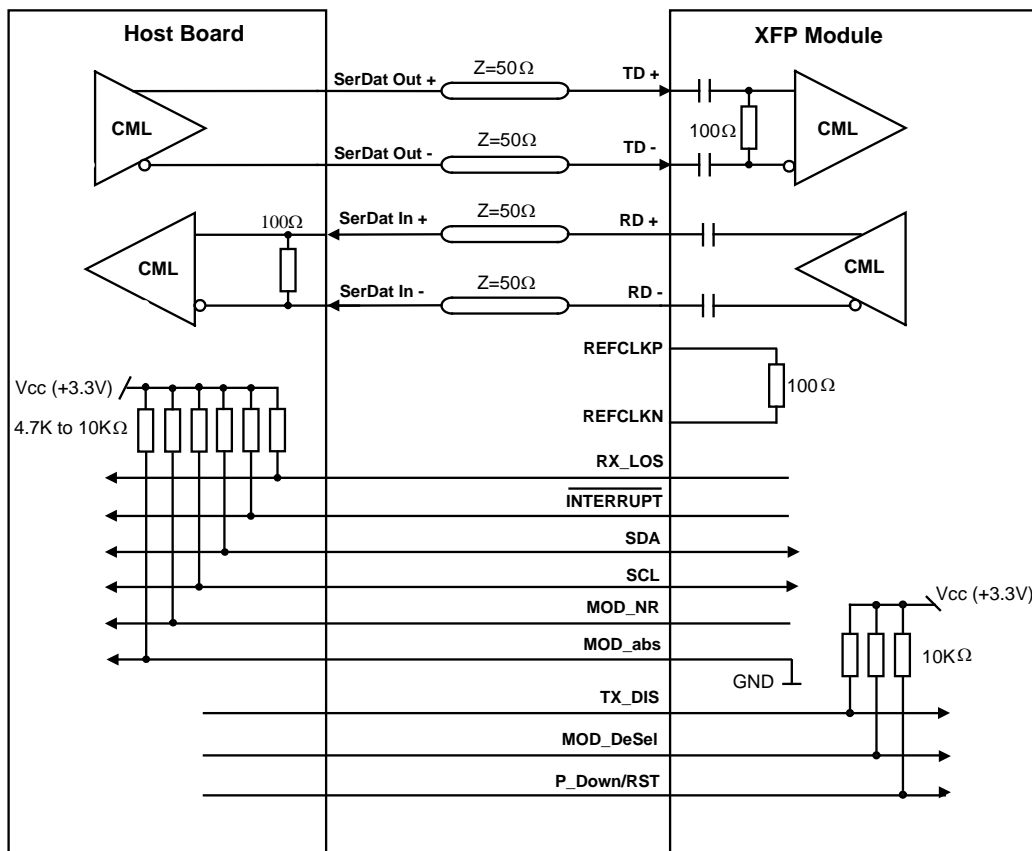
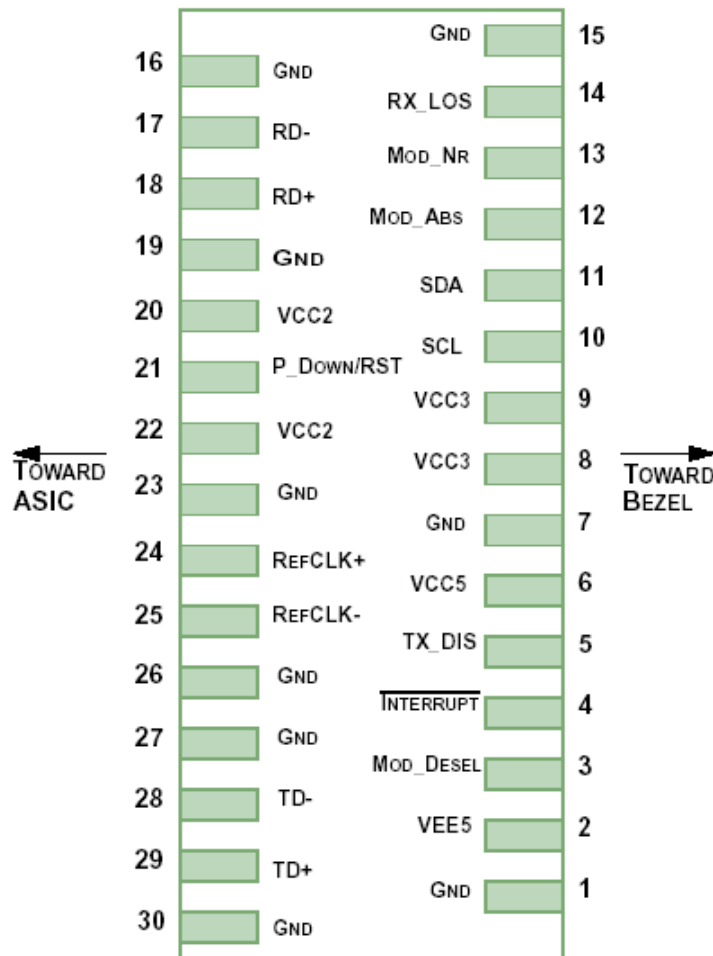

Figure 2, Recommended Interface Circuit

Pin Definitions

Figure 3, Pin View
Table 6 – Electrical Characteristics

Pin	Logic	Symbol	Name/Description	Note
1		GND	Module Ground	1
2		V _{EE5}	Optional -5.2V Power Supply (Not implemented)	3
3	LVTTL-I	Mod_Desel	Module De-select; When held low allows the module to respond to 2-wire serial interface	
4	LVTTL-O	<u>Interrupt</u>	<u>Interrupt</u> ; Indicates presence of an important condition which can be read over the 2-wire serial interface	2
5	LVTTL-I	TX_DIS	Transmitter Disable; Turns off transmitter laser output	
6		V _{CC5}	+5V Power Supply	
7		GND	Module Ground	1
8		V _{CC3}	+3.3V Power Supply	
9		V _{CC3}	+3.3V Power Supply	
10	LVTTL-I/O	SCL	2-Wire Serial Interface Clock	2
11	LVTTL-I/O	SDA	2-Wire Serial Interface Data Line	2

12	LVTTL-O	Mod_Abs	Indicates Module is not present. Grounded in the Module	2
13	LVTTL-O	Mod_NR	Module Not Ready; Indicating Module Operational Fault	2
14	LVTTL-O	RX_LOS	Receiver Loss Of Signal Indicator	2
15		GND	Module Ground	1
16		GND	Module Ground	1
17	CML-O	RD-	Receiver Inverted Data Output	
18	CML-O	RD+	Receiver Non-Inverted Data Output	
19		GND	Module Ground	1
20		V _{CC2}	+1.8V Power Supply	
21	LVTTL-I	P_Down/RST	Power down; When high, requires the module to limit power consumption to 1.5W or below. 2-Wire serial interface must be functional in the low power mode.	
			Reset; The falling edge initiates a complete reset of the module including the 2-wire serial interface, equivalent to a power cycle.	
22		V _{CC2}	+1.8V Power Supply	
23		GND	Module Ground	1
24	PECL-I	RefCLK+	Not used, internally terminated to 50ohm (100ohm diff).	4
25	PECL-I	RefCLK-	Not used, internally terminated to 50ohm (100ohm diff).	4
26		GND	Module Ground	1
27		GND	Module Ground	1
28	CML-I	TD-	Transmitter Inverted Data Input	
29	CML-I	TD+	Transmitter Non-Inverted Data Input	
30		GND	Module Ground	1

Notes:

1. Module ground pins GND are isolated from the module case and chassis ground within the module.
2. Shall be pulled up with 4.7K-10Kohms to a voltage between 3.15V and 3.45V on the host board.
3. The pins are open within module.
4. Reference Clock is not required

Mechanical Diagram

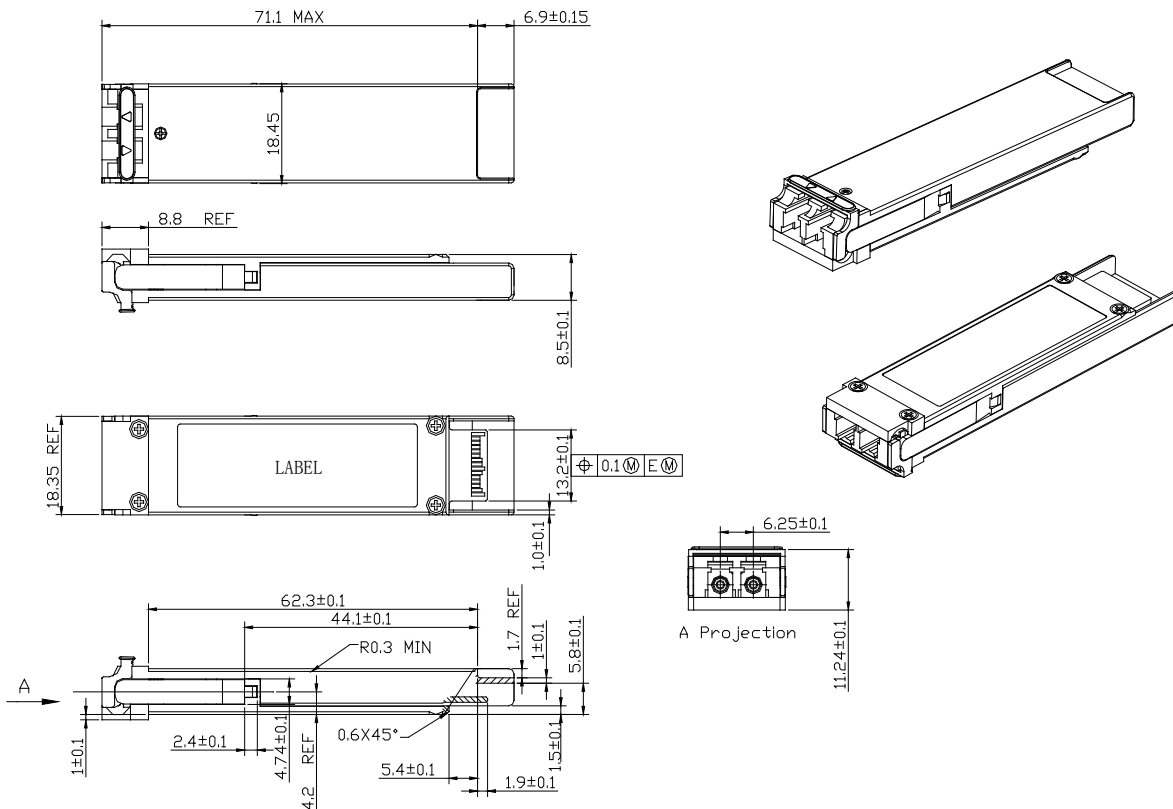

Figure 4, Mechanical Diagram of XFP

Order Information

Table 7– Order Information

Part No.	Application	Data Rate	Laser Source	Fiber Type	Latch Color
XP-XE-04-CDFA	10GBASE-ER	10.3125G	1550nm EML	SMF	Red

Warnings

Handling Precautions: This device is susceptible to damage as a result of electrostatic discharge (ESD). A static free environment is highly recommended. Follow guidelines according to proper ESD procedures.

Laser Safety: Radiation emitted by laser devices can be dangerous to human eyes. Avoid eye exposure to direct or indirect radiation.

Legal Notice

IMPORTANT NOTICE!

All information contained in this document is subject to change without notice, at Source Photonics's sole and absolute discretion. Source Photonics warrants performance of its products to current specifications

only in accordance with the company's standard one-year warranty; however, specifications designated as "preliminary" are given to describe components only, and Source Photonics expressly disclaims any and all warranties for said products, including express, implied, and statutory warranties, warranties of merchantability, fitness for a particular purpose, and non-infringement of proprietary rights. Please refer to the company's Terms and Conditions of Sale for further warranty information.

Source Photonics assumes no liability for applications assistance, customer product design, software performance, or infringement of patents, services, or intellectual property described herein. No license, either express or implied, is granted under any patent right, copyright, or intellectual property right, and Source Photonics makes no representations or warranties that the product(s) described herein are free from patent, copyright, or intellectual property rights. Products described in this document are NOT intended for use in implantation or other life support applications where malfunction may result in injury or death to persons. Source Photonics customers using or selling products for use in such applications do so at their own risk and agree to fully defend and indemnify Source Photonics for any damages resulting from such use or sale.

THE INFORMATION CONTAINED IN THIS DOCUMENT IS PROVIDED ON AN "AS IS" BASIS. Customer agrees that Source Photonics is not liable for any actual, consequential, exemplary, or other damages arising directly or indirectly from any use of the information contained in this document. Customer must contact Source Photonics to obtain the latest version of this publication to verify, before placing any order, that the information contained herein is current.

Contact

U.S.A. Headquarters

20550 Nordhoff Street
Chatsworth, CA 91311
USA
Tel: +1-818-773-9044
Fax: +1-818-773-0261

China

Building #2&5, West Export Processing Zone
No. 8 Kexin Road, Hi-Tech Zone
Chengdu, 611731, China
Tel: +86-28-8795-8788
Fax: +86-28-8795-8789

Taiwan

9F, No 81, Shui Lee Rd.
Hsinchu, Taiwan, R.O.C.
Tel: +886-3-5169222
Fax: +886-3-5169213

© Copyright Source Photonics, Inc. 2008~2009

All rights reserved