



Features

- Available in all 100GHz C-Band Wavelengths on the DWDM ITU Grid
- Support multi-rate from 9.953G to 11.3G
- Up to 40km transmission on SMF
- 1550nm EML laser and PIN receiver
- Dual CDR integrated
- SFI high speed electrical interface
- 2-wire interface with integrated Digital Diagnostic monitoring
- SFP+ MSA package with duplex LC connector
- Single +3.3V power supply
- Power consumption less than 2W
- Operating case temperature: -5~+70°C

Regulatory Compliance

Table 1 - Regulatory Compliance

Feature	Standard	Performance
Electrostatic Discharge (ESD) to the Electrical Pins	MIL-STD-883E Method 3015.7	Class 1(>1000V for SFI pins, >2000V for other pins.)
Electrostatic Discharge (ESD) to the Duplex LC Receptacle	IEC 61000-4-2 GR-1089-CORE	Compatible with standards
Electromagnetic Interference (EMI)	FCC Part 15 Class B EN55022 Class B (CISPR 22B) VCCI Class B	Compatible with standards
Immunity	IEC 61000-4-3	Compatible with standards
Laser Eye Safety	FDA 21CFR 1040.10 EN60950, EN (IEC) 60825-1,2	Compatible with Class I laser product.
RoHS	2011/65/EU	Compliant with standards

Absolute Maximum Ratings

Table 2 - Absolute Maximum Ratings

Parameter	Symbol	Min.	Typical	Max.	Unit	Notes
Storage Temperature	T_s	-40	-	+85	°C	
Supply Voltage	V_{CC}	-0.5	-	+4.0	V	
Operating Relative Humidity	RH	-	-	+85	%	

Recommended Operating Conditions

Table 3 – Recommended Operating Conditions

Parameter	Symbol	Min.	Typical	Max.	Unit	Notes
Operating Case Temperature	T_C	-5	-	+70	°C	
Power Supply Voltage	V_{CC}	3.14	3.3	3.47	V	
Power Supply Current	I_{CC}	-	400	600	mA	
Power Dissipation	P_D	-	1.3	2.0	W	1
Bit Rate	BR	9.953	-	11.3	Gbps	
Transmission Distance	TD	-	-	40	km	2

Notes:

1. The maximum power consumption is specified at 3.3V power supply voltage and beginning of life.
2. Measured with G.652 SMF.

Optical Characteristics

Table 4 – Optical Characteristics

Transmitter						
Parameter	Symbol	Min.	Typical	Max.	Unit	Notes
Center Wavelength Range	λ_C	1529.55	-	1560.61	nm	
	f_C	196.0	-	192.1	THz	
Channel Space	Δf	-	100	-	GHz	
Center Wavelength Tolerance	$\Delta \lambda_C$	-100	-	100	pm	
Average Output Power	P_{OUT}	-1		2	dBm	1
Average Output Power (Laser Off)	$P_{OUT-OFF}$	-	-	-35	dBm	1
Side Mode Suppression Ratio	SMSR	35	-	-	dB	
Spectral Width (-20dB)	$\Delta \lambda_{20}$	-	-	0.3	nm	
Extinction Ratio	ER	8.2	-	-	dB	2
Dispersion Penalty @9.95/10.7Gbp	DP_1	-	-	2	dB	3, 4
Dispersion Penalty @11.1/11.3Gbps	DP_2	-	-	3	dB	3, 4

Jitter Generation (peak to peak)	20kHz~80MHz	Jp-p	-	-	0.3	UI		
	4MHz~80MHz	Jp-p	-	-	0.1	UI		
Relative Intensity Noise		RIN	-	-	-130	dB/Hz		
Reflectance Tolerance		RT	-	-	-27	dB		
Optical Eye Mask		Compliant with ITU-T G.691-2006						2
Receiver								
Center Wavelength Range		λ_C	1528	-	1565	nm		
Receiver Sensitivity @ 9.95/10.7Gbps		$P_{IN-SENS@1}$	-	-	-16	dBm	3	
Receiver Sensitivity @ 11.1/11.3Gbps		$P_{IN-SENS@2}$	-	-	-15	dBm	3	
Receiver Overload		P_{IN-OL}	0	-	-	dBm	3	
Receiver Reflectance		ORL	-	-	-27	dB		
LOS Assert		LOS_A	-26	-	-	dBm		
LOS Deassert		LOS_D	-	-	-16	dBm		
LOS Hysteresis		LOS_H	0.5	-	4	dB		

Notes:

1. The optical power is launched into SMF.
2. Measured with a PRBS $2^{31}-1$ test pattern @9.95Gbps.
3. Measured with a PRBS $2^{31}-1$ test pattern, $BER \leq 10^{-12}$.
4. Measured with 40km G.652 SMF.

Electrical Characteristics

Table 5 – Electrical Characteristics

Transmitter							
Parameter		Symbol	Min.	Typical	Max.	Unit	Notes
Differential Data Input Amplitude		$V_{IN,P-P}$	190	-	700	mVpp	
Input Differential Impedance		Z_{IN}	85	100	115	Ω	
Tx_Fault	Normal Operation	V_{OL}	-0.3	-	0.4	V	
	Transmitter Fault	V_{OH}	2.4	-	V_{CC}	V	
Tx_Disable	Normal Operation	V_{IL}	-0.3	-	0.8	V	
	Laser Disable	V_{IH}	2.0	-	$V_{CC}+0.3$	V	
Receiver							
Differential Data Output Amplitude		$V_{OUT,P-P}$	300	-	850	mVpp	
Output Differential Impedance		Z_O	80	100	120	Ω	
Rx_LOS	Normal Operation	V_{OL}	-0.3	-	0.4	V	
	Lose Signal	V_{OH}	2.4	-	V_{CC}	V	

Recommended Host Board Power Supply Circuit

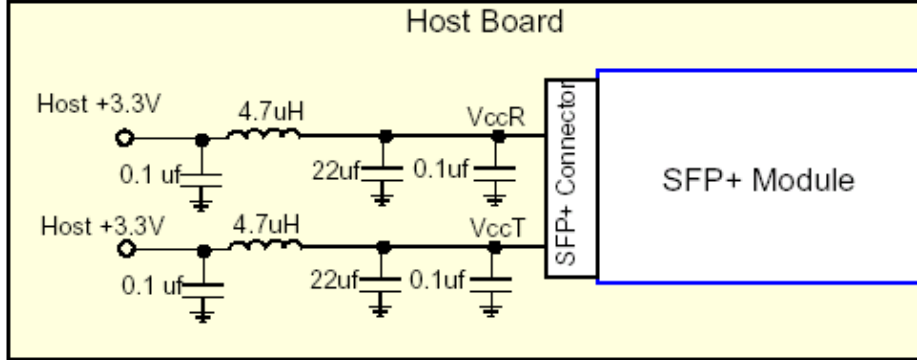

Figure 1, Recommended Host Board Power Supply Circuit

Recommended Interface Circuit

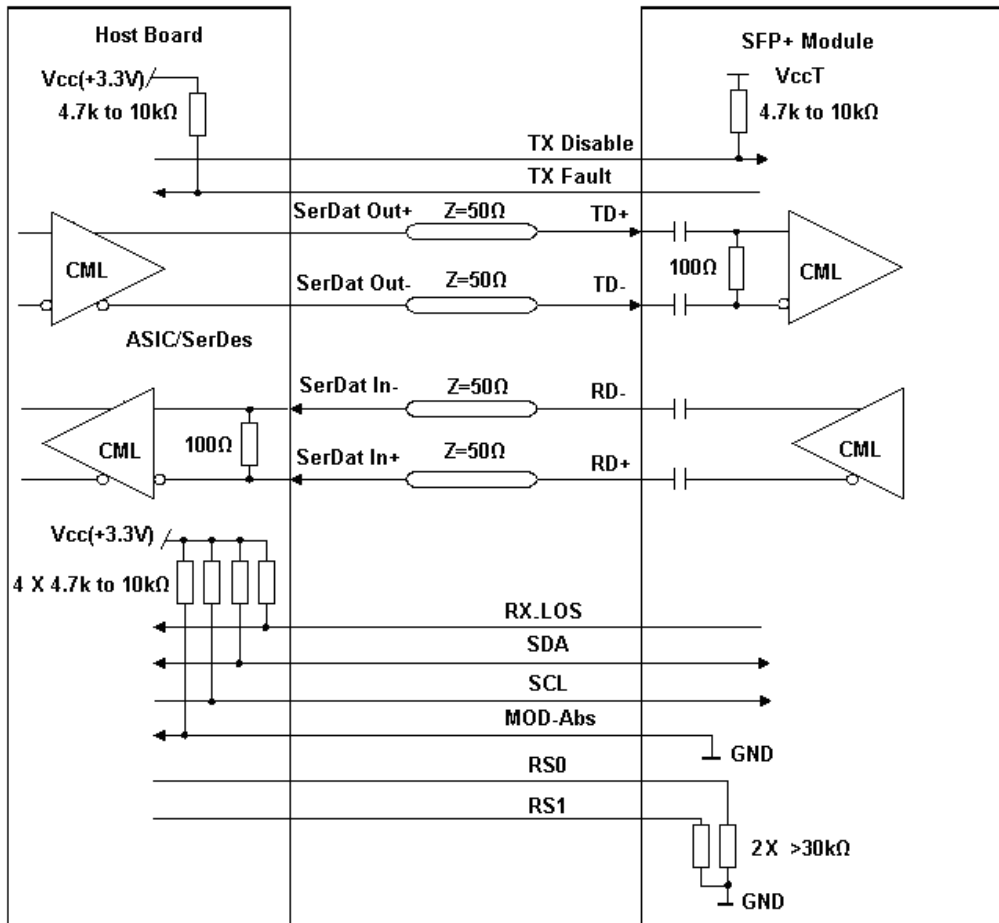

Figure 2, Recommended Interface Circuit

Pin Definitions

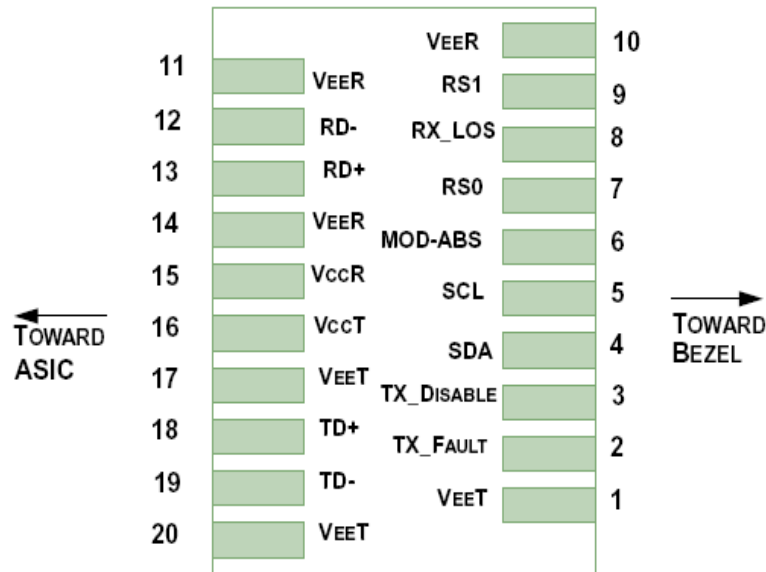

Figure 3, Pin View

Table 6–Pin Function Definitions

Pin	Logic	Symbol	Name/Description	Note
1		$V_{EE T}$	Module Transmitter Ground	1
2	LVTTL-O	$T X_{_F A U L T}$	Module Transmitter Fault	2
3	LVTTL-I	$T X_{_D I S A B L E}$	Transmitter Disable; Turns off transmitter laser output	3
4	LVTTL-I/O	SDL	2-Wire Serial Interface Data Line (MOD-DEF2)	
5	LVTTL-I/O	SCL	2-Wire Serial Interface Clock (MOD-DEF1)	
6		MOD_ABS	Module Absent, connected to $V_{EE T}$ or $V_{EE R}$ in the module	2
7	LVTTL-I	RS0	Rate Select 0, NOT implement	4
8	LVTTL-O	RX_LOS	Receiver Loss of Signal Indication (in FC designated as RX_LOS, in SONET designated as LOS, and in Ethernet designated as NOT Signal Detect)	2
9	LVTTL-I	RS1	Rate Select 1, NOT implement	4
10		$V_{EE R}$	Module Receiver Ground	1
11		$V_{EE R}$	Module Receiver Ground	1
12	CML-O	RD-	Receiver Inverted Data Output	
13	CML-O	RD+	Receiver Non-Inverted Data Output	
14		$V_{EE R}$	Module Receiver Ground	1
15		$V_{C C R}$	Module Receiver 3.3 V Supply	
16		$V_{C C T}$	Module Transmitter 3.3 V Supply	
17		$V_{EE T}$	Module Transmitter Ground	1
18	CML-I	TD+	Transmitter Non-Inverted Data Input	
19	CML-I	TD-	Transmitter Inverted Data Input	
20		$V_{EE T}$	Module Transmitter Ground	1

Notes:

1. The module ground pins are isolated from the module case.
2. The pins shall be pulled up with 4.7K-10Kohms to a voltage between 3.14V and 3.47V on host board.
3. The pin is pulled up to V_{CCT} with a 4.7K-10K Ω resistor in the module.
4. The pins are not connected in the module.

Mechanical Diagram

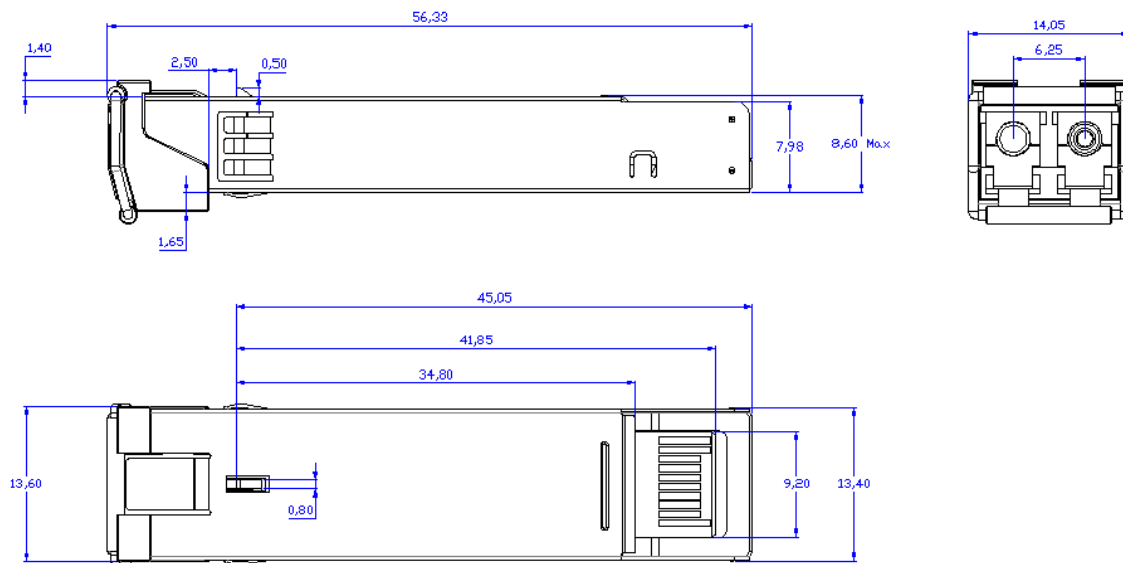

Figure 4, Mechanical Diagram of SFP+

Order Information

Table 7 – Order Information

Part No.	Application	Data Rate	Laser Source	Fiber Type	Latch Color
SPD-10S-ER-XXCDFA	S-64.2b 10GBASE-ER/W	9.953~11.3G	1550nm EML	SMF	Red

Note: see Table 10 – Wavelength Guide for “xx” value.

Table 10 – Wavelength Guide (xx value)

ITU Channel (xx)	Frequency (THz)	Wavelength (nm)	ITU Channel (xx)	Frequency (THz)	Wavelength (nm)
21	192.1	1560.606	41	194.1	1544.526
22	192.2	1559.794	42	194.2	1543.730
23	192.3	1558.983	43	194.3	1542.936
24	192.4	1558.173	44	194.4	1542.142
25	192.5	1557.363	45	194.5	1541.349

26	192.6	1556.555	46	194.6	1540.557
27	192.7	1555.747	47	194.7	1539.766
28	192.8	1554.940	48	194.8	1538.976
29	192.9	1554.134	49	194.9	1538.186
30	193.0	1553.329	50	195.0	1537.397
31	193.1	1552.524	51	195.1	1536.609
32	193.2	1551.721	52	195.2	1535.822
33	193.3	1550.918	53	195.3	1535.036
34	193.4	1550.116	54	195.4	1534.250
35	193.5	1549.315	55	195.5	1533.465
36	193.6	1548.515	56	195.6	1532.681
37	193.7	1547.715	57	195.7	1531.898
38	193.8	1546.917	58	195.8	1531.116
39	193.9	1546.119	59	195.9	1530.334
40	194.0	1545.322	60	196.0	1529.553

Warnings

Handling Precautions: This device is susceptible to damage as a result of electrostatic discharge (ESD). A static free environment is highly recommended. Follow guidelines according to proper ESD procedures.

Laser Safety: Radiation emitted by laser devices can be dangerous to human eyes. Avoid eye exposure to direct or indirect radiation.

Legal Notice

IMPORTANT NOTICE!

All information contained in this document is subject to change without notice, at Source Photonics's sole and absolute discretion. Source Photonics warrants performance of its products to current specifications only in accordance with the company's standard one-year warranty; however, specifications designated as "preliminary" are given to describe components only, and Source Photonics expressly disclaims any and all warranties for said products, including express, implied, and statutory warranties, warranties of merchantability, fitness for a particular purpose, and non-infringement of proprietary rights. Please refer to the company's Terms and Conditions of Sale for further warranty information.

Source Photonics assumes no liability for applications assistance, customer product design, software performance, or infringement of patents, services, or intellectual property described herein. No license, either express or implied, is granted under any patent right, copyright, or intellectual property right, and Source Photonics makes no representations or warranties that the product(s) described herein are free from patent, copyright, or intellectual property rights. Products described in this document are NOT intended for use in implantation or other life support applications where malfunction may result in injury or death to persons. Source Photonics customers using or selling products for use in such applications do so at their own risk and agree to fully defend and indemnify Source Photonics for any damages resulting from such use or sale.

THE INFORMATION CONTAINED IN THIS DOCUMENT IS PROVIDED ON AN "AS IS" BASIS. Customer agrees that Source Photonics is not liable for any actual, consequential, exemplary, or other damages arising directly or indirectly from any use of the information contained in this document. Customer must contact Source Photonics to obtain the latest version of this publication to verify, before placing any order, that the information contained herein is current.

Contact

U.S.A. Headquarters

20550 Nordhoff Street
Chatsworth, CA 91311
USA

Tel: +1-818-773-9044

Fax: +1-818-773-0261

China

Building #2&5, West Export Processing Zone
No. 8 Kexin Road, Hi-Tech Zone
Chengdu, 611731, China

Tel: +86-28-8795-8788

Fax: +86-28-8795-8789

Taiwan

9F, No 81, Shui Lee Rd.
Hsinchu, Taiwan, R.O.C.

Tel: +886-3-5169222

Fax: +886-3-5169213

© Copyright Source Photonics, Inc. 2007~2014

All rights reserved