

Features



- Support 10G Ethernet, CPRI and Fiber Channel application
- Simplex LC Connector, Bi-directional
- Up to 10km transmission on SMF
- 1270nm DFB laser and 1330nm PIN receiver
- SFI high speed electrical interface
- 2-wire interface with integrated Digital Diagnostic monitoring
- SFP+ MSA package with duplex LC connector
- Single +3.3V power supply
- Power consumption less than 1.0 W
- Operating case temperature: -40~+85°C

Regulatory Compliance

Table 1 - Regulatory Compliance

Feature	Standard	Performance
Electrostatic Discharge (ESD) to the Electrical Pins	MIL-STD-883E Method 3015.7	Class 1(>1000V for SFI pins, >2000V for other pins.)
Electrostatic Discharge (ESD) to the Duplex LC Receptacle	IEC 61000-4-2 GR-1089-CORE	Compatible with standards
Electromagnetic Interference (EMI)	FCC Part 15 Class B EN55022 Class B (CISPR 22B) VCCI Class B	Compatible with standards
Immunity	IEC 61000-4-3	Compatible with standards
Laser Eye Safety	FDA 21CFR 1040.10 and 1040.11 EN60950, EN (IEC) 60825-1,2	Compatible with Class I laser product.
RoHS	2011/65/EU	Compliant with standards

Absolute Maximum Ratings

Table 2 - Absolute Maximum Ratings

Parameter	Symbol	Min.	Typical	Max.	Unit	Notes
Storage Temperature	T_s	-40	-	+85	°C	
Supply Voltage	V_{CC}	-0.5	-	+4.0	V	
Operating Relative Humidity	RH	-	-	+85	%	

Recommended Operating Conditions

Table 3 – Recommended Operating Conditions

Parameter	Symbol	Min.	Typical	Max.	Unit	Notes
Operating Case Temperature	T_C	-40	-	+85	°C	
Power Supply Voltage	V_{CC}	3.14	3.3	3.46	V	
Power Supply Current	ICC	-	-	300	mA	
Power Dissipation	PD	-	-	1.0	W	2
Bit Rate	BR	-	10.3125	-	Gbps	
Transmission Distance	TD	2	-	10,000	m	1

Notes

1. Measured with SMF.
2. Measured at typical supply voltage 3.3V

Optical Characteristics

Table 4 – Optical Characteristics

Transmitter						
Parameter	Symbol	Min.	Typical	Max.	Unit	Notes
Center Wavelength Range	λ_C	1260	1270	1280	nm	
Average Output Power	P_{OUT}	-8.2	-	0.5	dBm	1
Optical Modulation Amplitude	OMA	-5.2	-	-	dBm	1
Average Output Power (Laser Off)	$P_{OUT-OFF}$	-	-	-30	dBm	1
Side Mode Suppression Ratio	SMSR	30	-	-	dB	
Extinction Ratio	ER	3.5	-	-	dB	2
Transmitter and Dispersion Penalty	TDP	-	-	3.2	dB	
Optical Eye Mask	Compliant with IEEE 802.3-2008					2
Receiver						
Center Wavelength Range	λ_C	1320	1330	1340	nm	
Receiver Sensitivity in OMA	$P_{IN-SENS(OMA)}$	-	-	-12.6	dBm	3
Receiver Overload	P_{IN-OL}	0.5	-	-	dBm	3

LOS Assert	LOS _A	-30	-	-	dBm	
LOS Deassert	LOS _D	-	-	-15	dBm	
LOS Hysteresis	LOS _H	0.5	-	-	dB	
Return Loss	RL	12	-	-	dB	

Notes:

1. The optical power is launched into SMF.
2. Measured with a PRBS 2³¹-1 test pattern @10.3125Gbps.
3. Measured with a PRBS 2³¹-1 test pattern @10.3125Gbps, BER≤10⁻¹².

Electrical Characteristics

Table 5 – Electrical Characteristics

Transmitter							
Parameter	Symbol	Min.	Typical	Max.	Unit	Notes	
Differential Data Input Amplitude	V _{IN,P-P}	180	-	700	mVpp		
Input Differential Impedance	Z _{IN}	85	100	115	Ω		
Tx_Fault	Normal Operation	V _{OL}	-0.3	-	0.4	V	
	Transmitter Fault	V _{OH}	2.4	-	V _{CC}	V	
Tx_Disable	Normal Operation	V _{IL}	-0.3	-	0.8	V	
	Laser Disable	V _{IH}	2.0	-	V _{CC} +0.3	V	
Receiver							
Differential Data Output Amplitude	V _{OUT,P-P}	300	-	850	mVpp		
Output Differential Impedance	Z _O	80	100	120	Ω		
Output Rise Time, 20%~80%	T _R	28	-	-	ps		
Output Fall Time, 20%~80%	T _F	28	-	-	ps		
Rx_LOS	Normal Operation	V _{OL}	-0.3	-	0.4	V	
	Lose Signal	V _{OH}	2.4	-	V _{CC}	V	

Recommended Host Board Power Supply Circuit

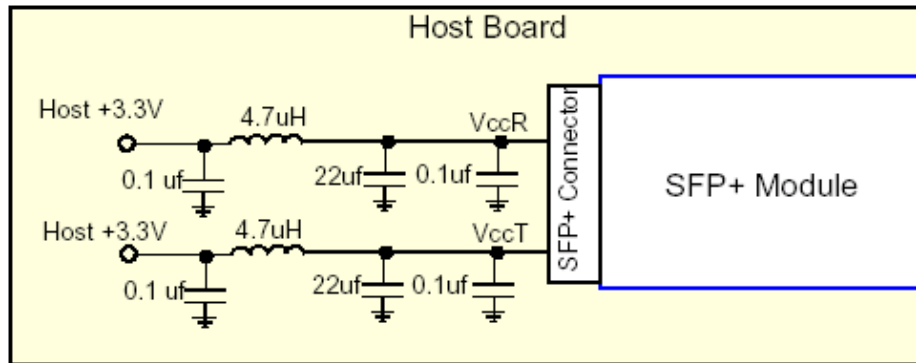

Figure 1, Recommended Host Board Power Supply Circuit

Recommended Interface Circuit

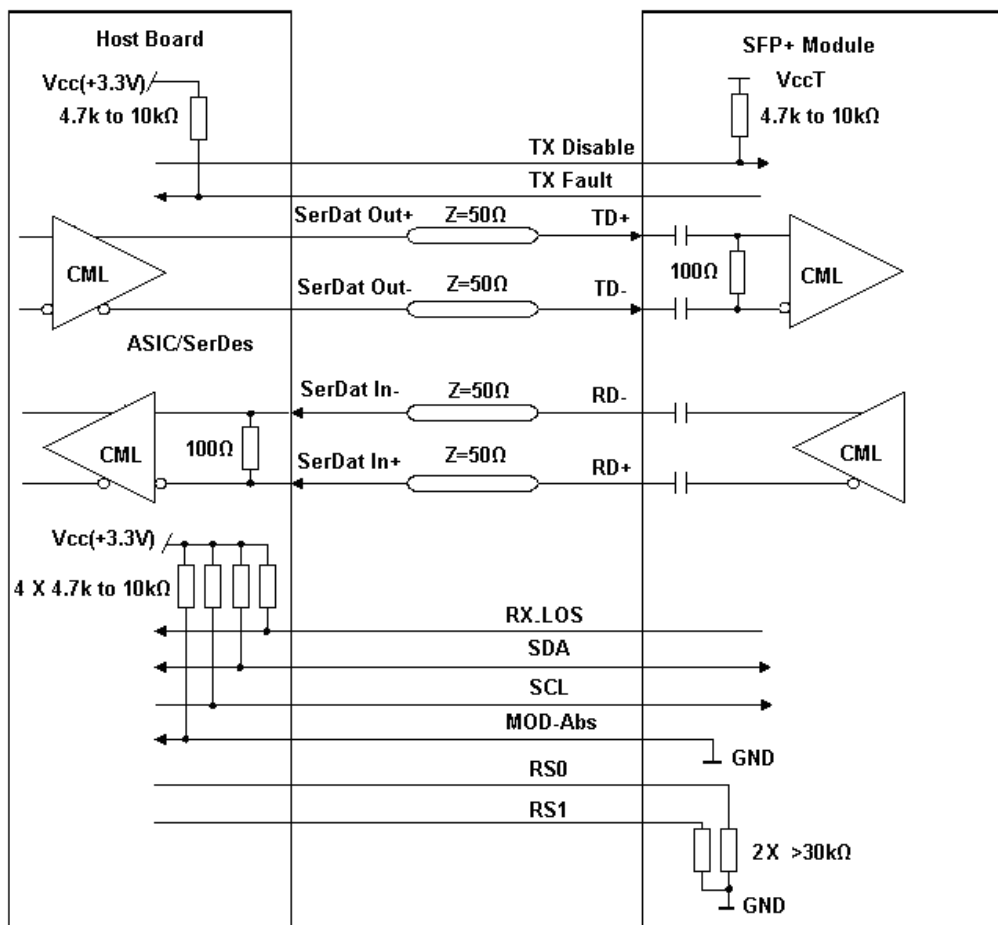

Figure 2, Recommended Interface Circuit

Pin Definitions

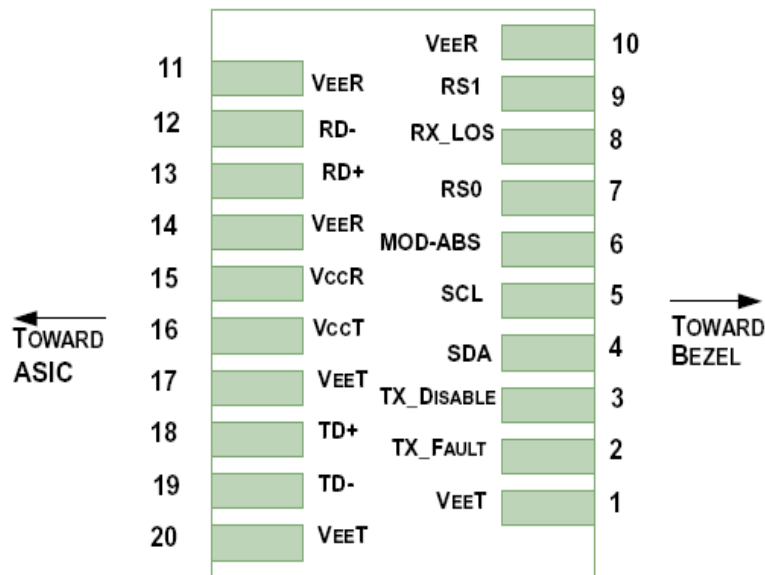

Figure 3, Pin View

Table 6–Pin Function Definitions

Pin	Logic	Symbol	Name/Description	Note
1		$V_{EE T}$	Module Transmitter Ground	1
2	LVTTL-O	$T X_{_F A U L T}$	Module Transmitter Fault	2
3	LVTTL-I	$T X_{_D I S A B L E}$	Transmitter Disable; Turns off transmitter laser output	3
4	LVTTL-I/O	SDL	2-Wire Serial Interface Data Line (MOD-DEF2)	
5	LVTTL-I/O	SCL	2-Wire Serial Interface Clock (MOD-DEF1)	
6		MOD_ABS	Module Absent, connected to $V_{EE T}$ or $V_{EE R}$ in the module	2
7	LVTTL-I	RS0	Rate Select 0, NOT implement	4
8	LVTTL-O	RX_LOS	Receiver Loss of Signal Indication (in FC designated as RX_LOS, in SONET designated as LOS, and in Ethernet designated as NOT Signal Detect)	2
9	LVTTL-I	RS1	Rate Select 1, NOT implement	4
10		$V_{EE R}$	Module Receiver Ground	1
11		$V_{EE R}$	Module Receiver Ground	1
12	CML-O	RD-	Receiver Inverted Data Output	
13	CML-O	RD+	Receiver Non-Inverted Data Output	
14		$V_{EE R}$	Module Receiver Ground	1
15		$V_{CC R}$	Module Receiver 3.3 V Supply	
16		$V_{CC T}$	Module Transmitter 3.3 V Supply	
17		$V_{EE T}$	Module Transmitter Ground	1
18	CML-I	TD+	Transmitter Non-Inverted Data Input	
19	CML-I	TD-	Transmitter Inverted Data Input	
20		$V_{EE T}$	Module Transmitter Ground	1

Notes:

1. The module ground pins are isolated from the module case.
2. The pins shall be pulled up with 4.7K-10Kohms to a voltage between 3.14V and 3.46V on host board.
3. The pin is pulled up to V_{CCT} with a 4.7K-10K Ω resistor in the module.
4. The pins are pulled low to V_{EET} with a >30k Ω resistor in the module.

Mechanical Diagram

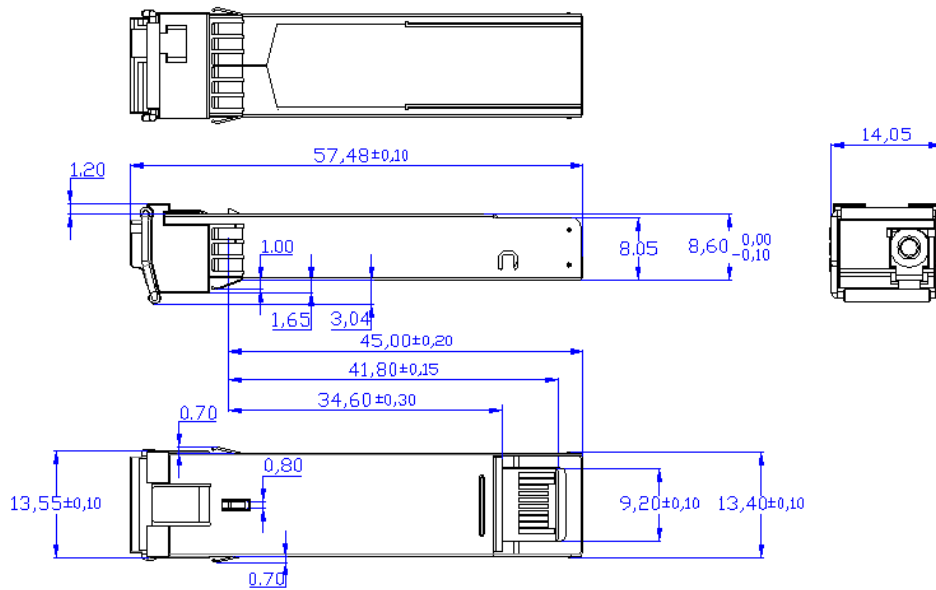

Figure 4, Mechanical Diagram of SFP+

Order Information

Table 7 – Order Information

Part No.	Application	Data Rate	Laser Source	Fiber Type	Latch color
SPPL-RO-XE-BX-IDFF	10GE/CPRI/10GFC	10.3125G	1270nm DFB	SMF	Grey

Warnings

Handling Precautions: This device is susceptible to damage as a result of electrostatic discharge (ESD). A static free environment is highly recommended. Follow guidelines according to proper ESD procedures.

Laser Safety: Radiation emitted by laser devices can be dangerous to human eyes. Avoid eye exposure to direct or indirect radiation.

Legal Notice

IMPORTANT NOTICE!

All information contained in this document is subject to change without notice, at Source Photonics's sole and absolute discretion. Source Photonics warrants performance of its products to current specifications only in accordance with the company's standard one-year warranty; however, specifications designated as "preliminary" are given to describe components only, and Source Photonics expressly disclaims any and all warranties for said products, including express, implied, and statutory warranties, warranties of merchantability, fitness for a particular purpose, and non-infringement of proprietary rights. Please refer to the company's Terms and Conditions of Sale for further warranty information.

Source Photonics assumes no liability for applications assistance, customer product design, software performance, or infringement of patents, services, or intellectual property described herein. No license, either express or implied, is granted under any patent right, copyright, or intellectual property right, and Source Photonics makes no representations or warranties that the product(s) described herein are free from patent, copyright, or intellectual property rights. Products described in this document are NOT intended for use in implantation or other life support applications where malfunction may result in injury or death to persons. Source Photonics customers using or selling products for use in such applications do so at their own risk and agree to fully defend and indemnify Source Photonics for any damages resulting from such use or sale.

THE INFORMATION CONTAINED IN THIS DOCUMENT IS PROVIDED ON AN "AS IS" BASIS. Customer agrees that Source Photonics is not liable for any actual, consequential, exemplary, or other damages arising directly or indirectly from any use of the information contained in this document. Customer must contact Source Photonics to obtain the latest version of this publication to verify, before placing any order, that the information contained herein is current.

Contact

U.S.A. Headquarters

20550 Nordhoff Street
Chatsworth, CA 91311
USA
Tel: +1-818-773-9044
Fax: +1-818-773-0261

China

Building #2&5, West Export Processing Zone
No. 8 Kexin Road, Hi-Tech Zone
Chengdu, 611731, China
Tel: +86-28-8795-8788
Fax: +86-28-8795-8789

Taiwan

9F, No 81, Shui Lee Rd.
Hsinchu, Taiwan, R.O.C.
Tel: +886-3-5169222
Fax: +886-3-5169213

© Copyright Source Photonics, Inc. 2007~2013

All rights reserved