

Features



- Support IEEE 802.3-2008 1000BASE-PX20++ GEAPON OLT side application
- Support GEAPON extended reach application
- Single fiber bi-directional data links with symmetric 1.25Gbps upstream and downstream
- Integrated with micro-optics WDM filter for dual wavelength Tx/Rx operation at 1490/1310nm
- 1490nm continuous-mode transmitter with DFB laser
- 1310nm burst-mode receiver with APD-TIA
- Support more than 24dB dynamic range
- Digital diagnostic interface compliant with SFF-8472 Rev 9.5
- Digital Receiving Signal Strength Indication (RSSI)
- Single 3.3V power supply
- Maximum 1W total power dissipation
- Spring-latch SFP (Small Form-factor Pluggable) package with SC receptacle optical interface.
- Operating case temperature: 0~70°C
- RoHS compliance

Regulatory Compliance

Table 1 - Absolute Maximum Ratings

Feature	Standard	Performance
Electrostatic Discharge (ESD) to the Electrical Pins	MIL-STD-883E Method 3015.7	Class 1(>500 V)
Electrostatic Discharge (ESD) to the Duplex LC Receptacle	IEC 61000-4-2	Compatible with standards
Electromagnetic Interference (EMI)	FCC Part 15 Class B EN55022 Class B (CISPR 22B)	Compatible with standards
Immunity	IEC 61000-4-3	Compatible with standards
Laser Eye Safety	FDA 21CFR 1040.10 and 1040.11 EN60950, EN (IEC) 60825-1,2	Compatible with Class I laser product.
Component Recognition	UL and CSA	Compliant with standards
RoHS	2002/95/EC 4.1&4.2 2005/747/EC	Compliant with standards ^{note}

Note:

In light of item 5 in Annex of 2002/95/EC, "Pb in the glass of cathode ray tubes, electronic components and fluorescent tubes." and item 13 in Annex of 2005/747/EC, "Lead and cadmium in optical and filter glass.", the two exemptions are being concerned for Source Photonics transceivers, because Source Photonics transceivers use glass, which may contain Pb, for components such as lenses, windows, isolators, and other electronic components.

Absolute Maximum Ratings

Table 2 - Absolute Maximum Ratings

Parameter	Symbol	Min.	Typical	Max.	Unit	Notes
Storage Ambient Temperature	T _s	-40	-	85	°C	
Operating Case Temperature	T _c	0		70	°C	1
Operating Relative Humidity	RH	5		95	%	
Power Supply Voltage	V _{CC}	0		4	V	
Input Voltage		GND		V _{CC}	V	
Receiver Damaged Threshold		0			dBm	

Note 1: When ambient temperature is above 60°C, airflow at rate higher than 1m/sec is required.

Recommended Operating Conditions

Table 3 – Recommended Operating Conditions

Parameter	Symbol	Min.	Typical	Max.	Unit	Notes
Power Supply Voltage	V _{CC}	3.13	3.3	3.47	V	
Operating Case Temperature	T _c	0		70	°C	1
Operating Relative Humidity	RH	5		95	%	
Data Rate			1.25		Gbit/s	
Data Rate Drift		-100		+100	PPM	

Note 1: When ambient temperature is above 60°C, airflow at rate higher than 1m/sec is required.

Optical Characteristics

Table 4 – Optical Characteristics

Transmitter						
Parameter	Symbol	Min.	Typical	Max.	Unit	Notes
Centre Wavelength	λ _c	1480		1500	nm	
Spectral Width (-20dB)	Δλ			1	nm	
Side Mode Suppression Ratio	SMSR	30			dB	
Average Launch Power	P _{OUT}	4.5		7	dBm	1
Average Launch Power-OFF Transmitter	P _{OFF}			-39	dBm	
Extinction Ratio	EX	9			dB	2
Total Jitter	TJ			0.43	UI	2
Rise/Fall Time (20%-80%)	T _R /T _F			260	ps	2,3
RIN ₁₅ OMA				-115	dB/Hz	

Optical Return Loss Tolerance				12	dB	
Transmitter Reflectance				-10	dB	
Transmitter and dispersion Penalty	TDP			2.3	dB	4
Optical Eye Mask	Compliant With IEEE Std 802.3ah™-2004					2,5
Receiver						
Operating Wavelength	λ_c	1260		1360	nm	
Sensitivity	P_{SEN}			-32	dBm	6
Saturation	P_{SAT}	-6			dBm	
Receiver Threshold Settling Time	$T_{SETTLING}$			250	ns	6,7
Dynamic Range		-32		-6	dBm	6,8
Loss of Signal Deassert Level	P_{LOSD}			-33	dBm	9
Loss of Signal Assert Level	P_{LOSA}	-45			dBm	10
LOS Hysteresis	$P_{LOSD} - P_{LOSA}$	0.5		6	dB	
Receiver Reflectance				-12	dB	

Notes:

1. The optical power is launched into 9/125um SMF.
2. Measured with PRBS 2⁷-1 test pattern @1.25Gbps.
3. Measured with the Bessel-Thompson filter OFF.
4. Maximum sensitivity penalty due to transmitter and dispersion effect through 20km of SMF optical fiber.
5. Transmitter eye mask definition {0.22UI, 0.375UI, 0.20UI, 0.20UI, 0.30UI}.
6. Measured with a PRBS 2⁷-1 test pattern @1.25Gbps and ER=10dB, BER =10⁻¹².
7. See Figure 1, 2. For multiple ONUs application, It isn't easy to test $T_{SETTLING}$ directly, but there is a relationship $T_{SETTLING} = T_{GAP} - T_{GUARD}$ when $T_{ON} = T_{OFF}$, then $T_{SETTLING}$ can be calculated by T_{GAP} and a certain guard time at ONU side.
8. See Figure 3. T_{GAP} be less than 250ns is guaranteed.
9. An increase in optical power above the specified level will cause Los of Signal (LOS) output to switch from a high state to a low state.
10. A decrease in optical power below the specified level will cause Los of Signal (LOS) output to switch from a low state to a high state.

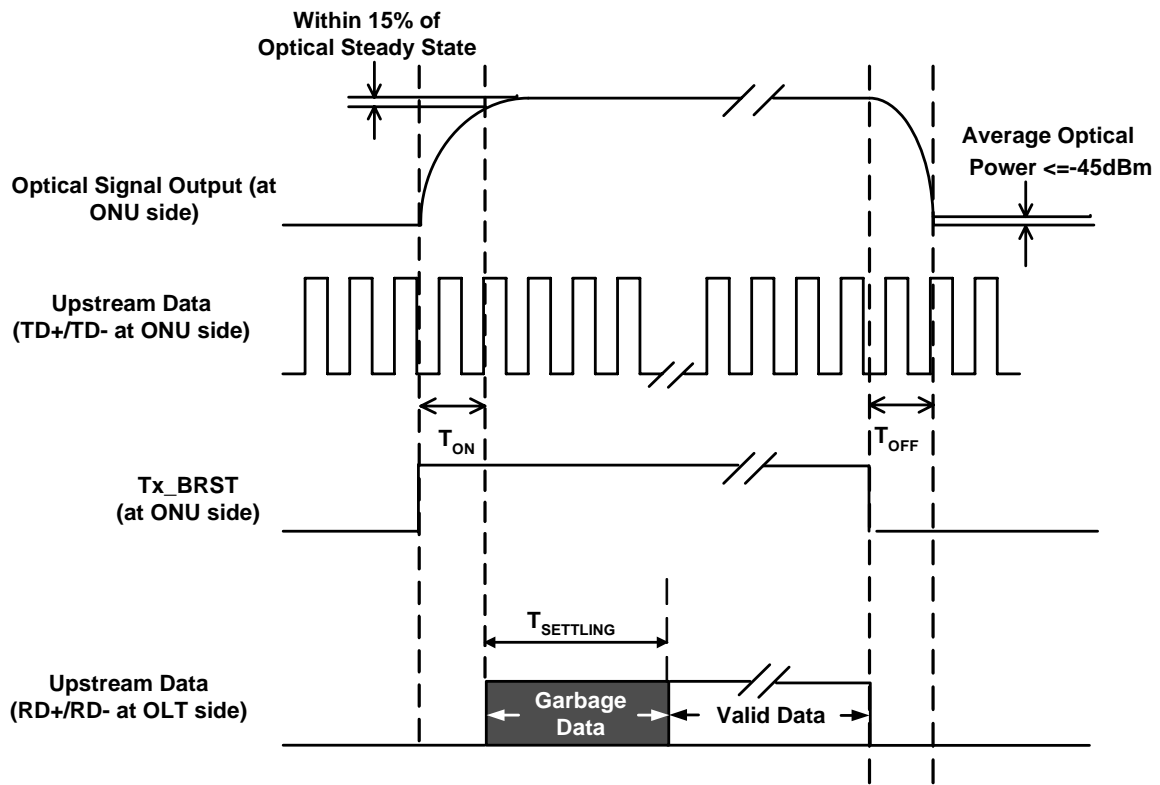

Figure 1, Timing Parameter Definition in Burst Mode Sequence (Sole ONU Application)

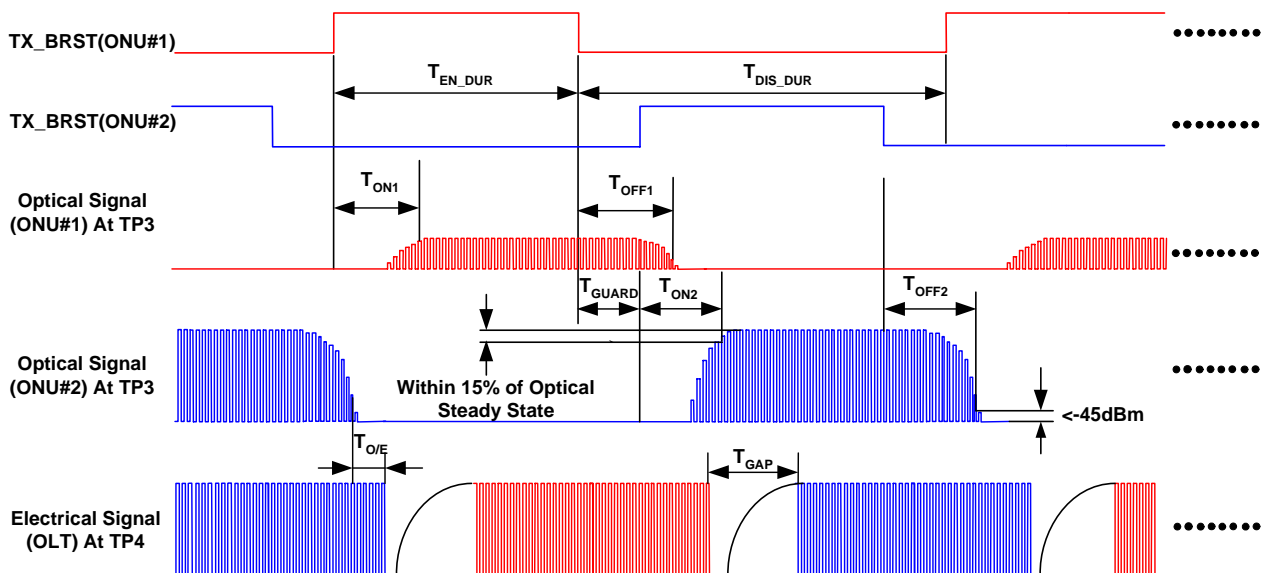
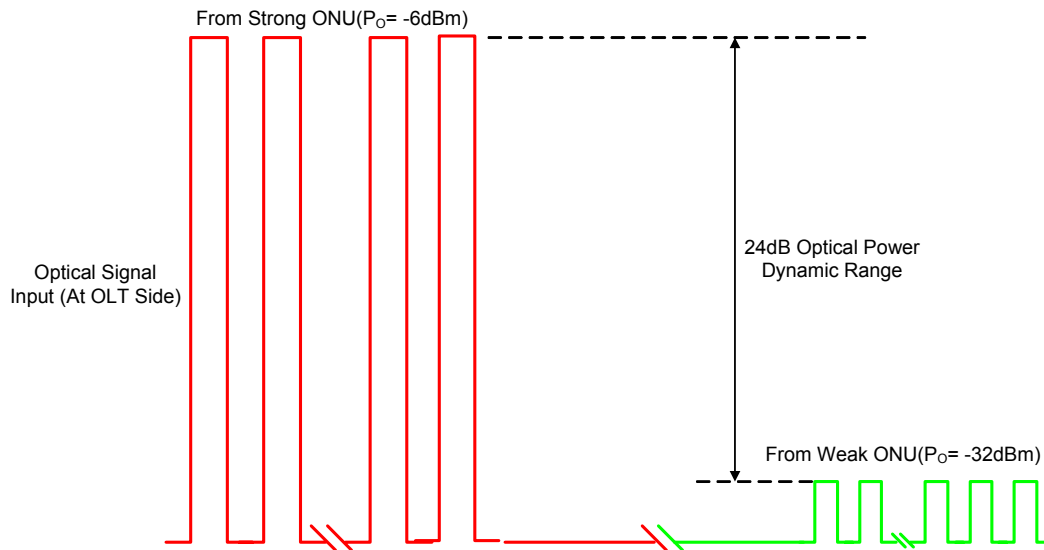

Figure 2, Timing Parameter Definition in Burst Mode Sequence (Dual ONUs Application)

Figure 3, Burst Mode Receiver Dynamic Range

Electrical Characteristics

Table 5 – Electrical Characteristics

Transmitter						
Parameter	Symbol	Min.	Typical	Max.	Unit	Notes
Power Supply Current	I_{CC_TX}			280	mA	
Data Input Differential Swing	V_{IN}	200		1600	mVp-p	1
Input Differential Impedance	Z_{IN}	90	100	110	Ω	
Transmitter Disable Voltage - Low	$V_{TDIS, L}$	0		0.8	V	2
Transmitter Disable Voltage - High	$V_{TDIS, H}$	2.0		V_{CC}	V	
Transmitter Fault Indication Voltage - Low	$V_{TFI, L}$	0		0.4	V	3
Transmitter Fault Indication Voltage - High	$V_{TFI, H}$	2.4		V_{CC}	V	
Receiver						
Power Supply Current	I_{CC_RX}			180	mA	4
Data Output Voltage - Low	$V_{OL-V_{CC}}$	-1.81		-1.62	V	
Data Output Voltage - High	$V_{OH-V_{CC}}$	-1.02		-0.88	V	
Data Output Differential Swing	V_{OUT}	400		1600	mV _{P-P}	5
Loss of Signal (LOS) Voltage - Low	$V_{LOS, L}$	0		0.8	V	6
Loss of Signal (LOS) Voltage - High	$V_{LOS, H}$	2.0		V_{CC}	V	
Loss of Signal (LOS) Assert Time	T_{ASS}			500	ns	
Loss of Signal (LOS) Deassert Time	T_{DAS}			500	ns	

Notes:

- Compatible with LVPECL input, AC coupled internally. (See [Recommended Interface Circuit](#))
- TX Disable (See [Pin Function Definitions](#)).
- TX Fault (See [Pin Function Definitions](#)) Internally AC coupled.

4. Supply current excluding receiver output load.
5. LVPECL output, DC coupled internally, guaranteed in the full range of input optical power (-6dBm to -33dBm) (See [Recommended Interface Circuit](#)).
6. LOS (See [Pin Function Definitions](#)).

Recommended Host Board Power Supply Circuit

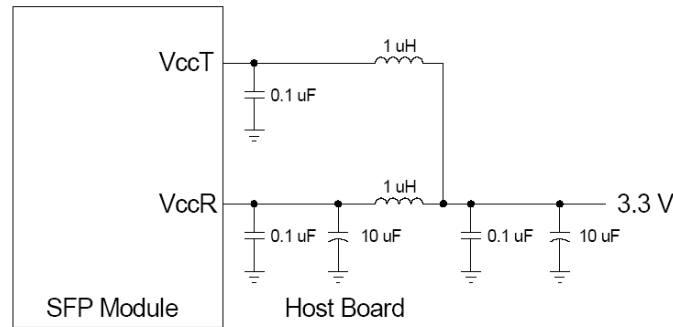

Figure 4, Recommended Host Board Power Supply Filtering Network

Recommended Interface Circuit

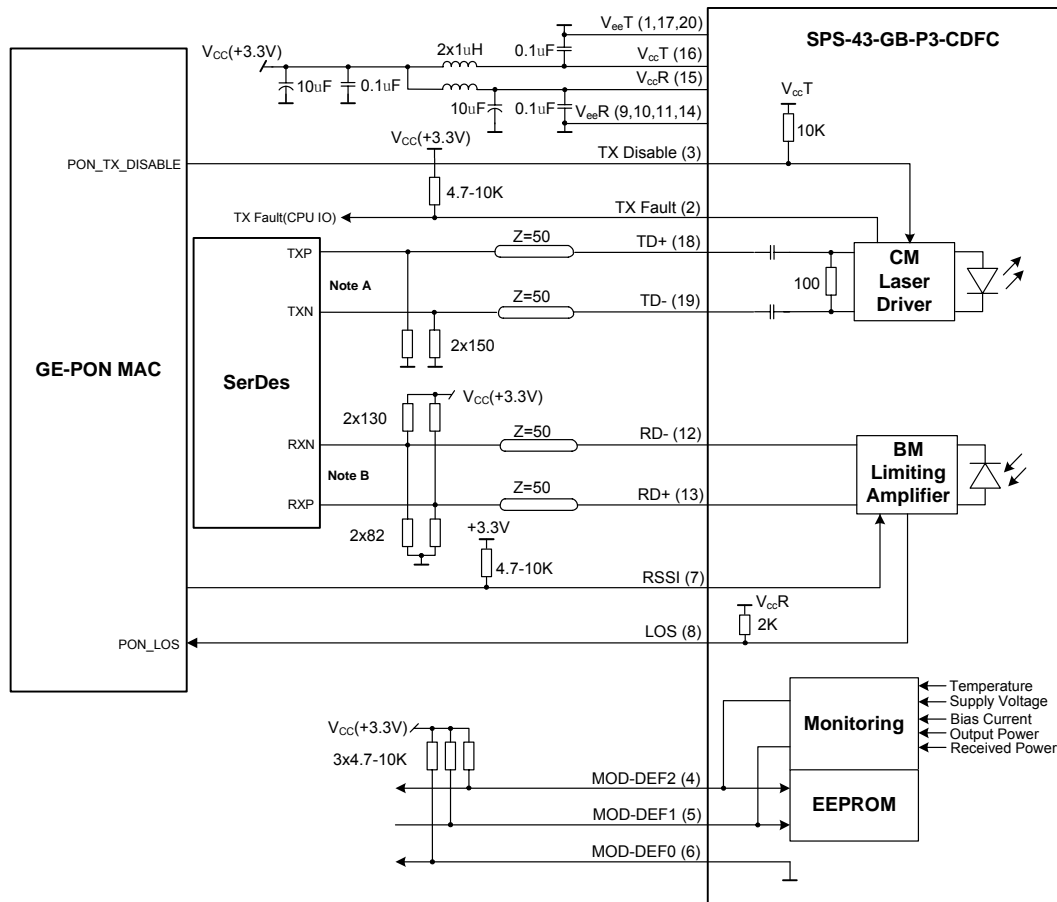

Figure 5, Recommended Interface Circuit

Note A: Circuit assumes open emitter output

Note B: Circuit assumes that proper internal bias voltage is not provided

Pin Definitions

Figure 6 below shows the pin numbering of SFP electrical interface (Golden Finger). The pin functions are described in Table 6 and the accompanying notes.

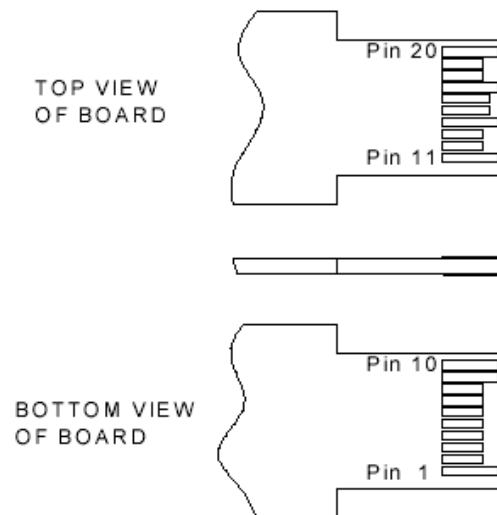

Figure 6, SFP Pin View (Golden Finger)

Table 6 –Pin Function Definitions

Pin	Name	Description	Notes
1	V _{ee} T	Transmitter Ground	
2	TX Fault	Transmitter Fault Indication	1
3	TX Disable	Transmitter Disable	2
4	MOD-DEF2	Module Definition 2	3
5	MOD-DEF1	Module Definition 1	
6	MOD-DEF0	Module Definition 0	
7	RSSI	LVTTTL Active high, controlled by MAC	
8	LOS	Loss of Signal	4
9	V _{ee} R	Receiver Ground	
10	V _{ee} R	Receiver Ground	
11	V _{ee} R	Receiver Ground	
12	RD-	Inv. Receiver Data Out	5
13	RD+	Receiver Data Out	
14	V _{ee} R	Received Ground	
15	V _{cc} R	Receiver Power	6
16	V _{cc} T	Transmitter Power	
17	V _{ee} T	Transmitter Ground	
18	TD+	Transmit Data In	7
19	TD-	Inv. Transmit Data In	
20	V _{ee} T	Transmitter Ground	

Notes:

1. TX Fault is an open collector/drain output, which should be pulled up with a 4.7K-10K Ω resistor on the host board. Pull up voltage between 2.0V and V_{ccT} , $R+0.3V$. When high, output indicates a laser fault of some kind. Low indicates normal operation. In the low state, the output will be pulled to $< 0.8V$.
2. TX disable is an input that is used to shut down the transmitter optical output. It is pulled up within the module with a 4.7-10 K Ω resistor. Its states are:
 - Low (0-0.8V): Transmitter on
 - (>0.8, < 2.0V): Undefined
 - High (2.0-3.465V): Transmitter Disabled
 - Open: Transmitter Disabled
3. MOD-DEF0,1,2. These are the module definition pins. They should be pulled up with a 4.7K-10K Ω resistor on the host board. The pull-up voltage shall be V_{ccT} or V_{ccR} .
 - MOD-DEF0 is grounded by the module to indicate that the module is present
 - MOD-DEF1 is the clock line of two-wire serial interface for serial ID
 - MOD-DEF2 is the data line of two-wire serial interface for serial ID
4. LOS (Loss of Signal) is an open collector/drain output, which should be pulled up with a 4.7K-10K Ω resistor. Pull up voltage between 2.0V and V_{ccT} , $R+0.3V$. When high, this output indicates the received optical power is below the worst-case receiver sensitivity (as defined by the standard in use). Low indicates normal operation. In the low state, the output will be pulled to $< 0.8V$.
5. These are the differential receiver outputs. They are DC coupled 100 Ω differential lines which should be terminated with 100 Ω (differential) at the user SERDES. (See [Recommended Interface Circuit](#))
6. V_{ccR} and V_{ccT} are the receiver and transmitter power supplies. They are defined as $3.3V\pm 5\%$ at the SFP connector pin. Maximum supply current is 300 mA. Recommended host board power supply filtering is shown in figure 4. Inductors with DC resistance of less than 1 Ω should be used in order to maintain the required voltage at the SFP input pin with 3.3V supply voltage. When the recommended supply filtering network is used, hot plugging of the SFP transceiver module will result in an inrush current of no more than 30 mA greater than the steady state value.
7. These are the differential transmitter inputs. They are AC coupled differential lines with 100 Ω differential termination inside the module. The AC coupling is done inside the module and is thus not required on the host board. (See)

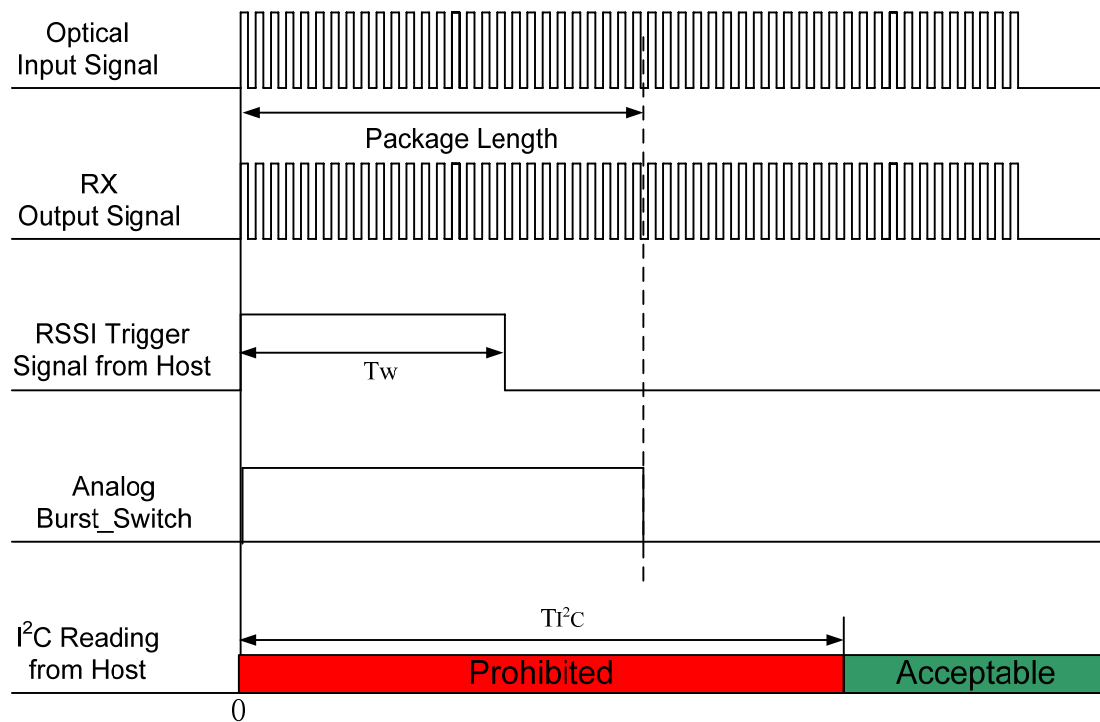

Figure 7, RSSI Timing Diagram

Table 7 – RSSI Parameter

Item	Symbol	Min	Typ	Max	unit
Trigger width	T_w		0.6		us
Package Length	T_{pk}	0.6	0.9		us
I ² C response time	T_{I^2C}			100	us

Notes:

1. The length of input signal package should not less than 1.25us.
2. The interval of two trigger signals should not less than 125us.

EEPROM Information

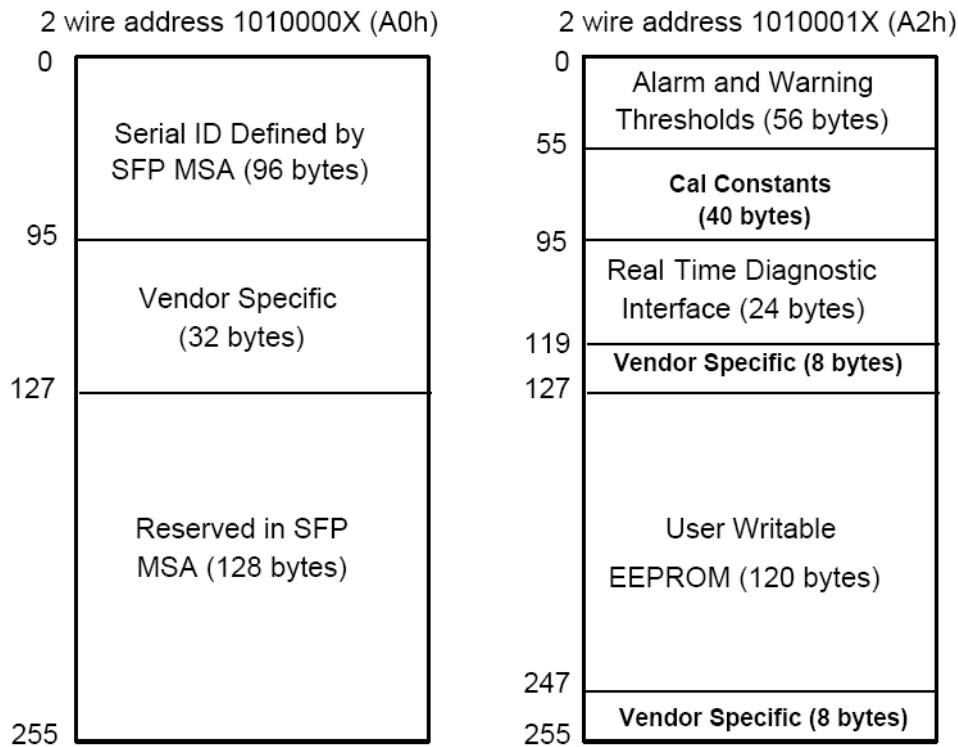

Figure 8, 2-wire Serial Digital Diagnostic Memory Map

Table 8 –EEPROM Serial ID Memory Contents (A0h)

Addr.	Field Size (Bytes)	Name of Field	Hex	Description
0	1	Identifier	03	SFP transceiver
1	1	Ext. Identifier	04	MOD4
2	1	Connector	01	SC
3-10	8	Transceiver	00 00 00 80 00 00 00 00	BASE-PX
11	1	Encoding	01	8B10B
12	1	BR, Nominal	0D	1.25Gbps
13	1	Reserved	00	
14	1	Length (9um)-km	1E	30(km)
15	1	Length (9um)	00	300(100m)
16	1	Length (50um)	00	Not Support MMF
17	1	Length (62.5um)	00	Not Support MMF
18	1	Length (Copper)	00	Not Support Copper
19	1	Reserved	00	
20-35	16	Vendor name	53 4F 55 52 43 45 50 48 4F 54 4F 4E 49 43 53 20	“SOURCEPHOTONICS”(ASC II)
36	1	Reserved	00	
37-39	3	Vendor OUI	00 00 00	

40-55	16	Vendor PN	53 50 53 34 33 47 42 50 33 43 44 46 42 20 20 20	"SPS43GBP3CDFC" (ASCII)
56-59	4	Vendor Rev	xx xx 20 20	ASCII("30 31 20 20" means 1.0 Revision)
60-61	2	Wavelength	05 D2	1490nm Laser Wavelength
62	1	Reserved	00	
63	1	CC_BASE	xx	Check sum of byte 0-62
64-65	2	Options	00 1A	LOS, TX_FAULT and TX_DISABLE
66	1	BR, max	00	
67	1	BR, min	00	
68-83	16	Vendor SN	xx xx xx xx xx xx xx xx xx xx xx xx xx xx xx xx	ASCII
84-91	8	Date code	xx xx xx xx xx xx 20 20	Year(2 bytes), Month(2 bytes), Day(2 bytes)
92	1	Diagnostic Monitoring Type	58	Compliant with SFF-8472 V9.5 Externally Calibrated Received power measurement type -Average Power
93	1	Enhanced Options	F0	Diagnostics (Optional Alarm/warning flags) Soft TX_FAULT monitoring implemented Soft RX_LOS monitoring implemented
94	1	SFF-8472 Compliance	02	Diagnostics Compliance(SFF-8472 V9.5)
95	1	CC_EXT		Check sum of byte 64-94
96-255	64	Vendor Specific		

Note: The "xx" byte should be filled in according to practical case. For more information, please refer to the related document of SFF-8472 Rev 9.5.

Table 9 – Digital Diagnostic Specification (A2h)

Data Address	Parameter	Range	Accuracy
96-97	Temperature	-40 to +80°C	±3°C
98-99	Vcc Voltage	+3.0V to +3.6V	±3%
100-101	Bias Current	0 to 100mA	±10%
102-103	TX Power	0 to 8dBm	±2dB
104-105	RX Power	-30 to -6dBm	±2dB

Mechanical Diagram

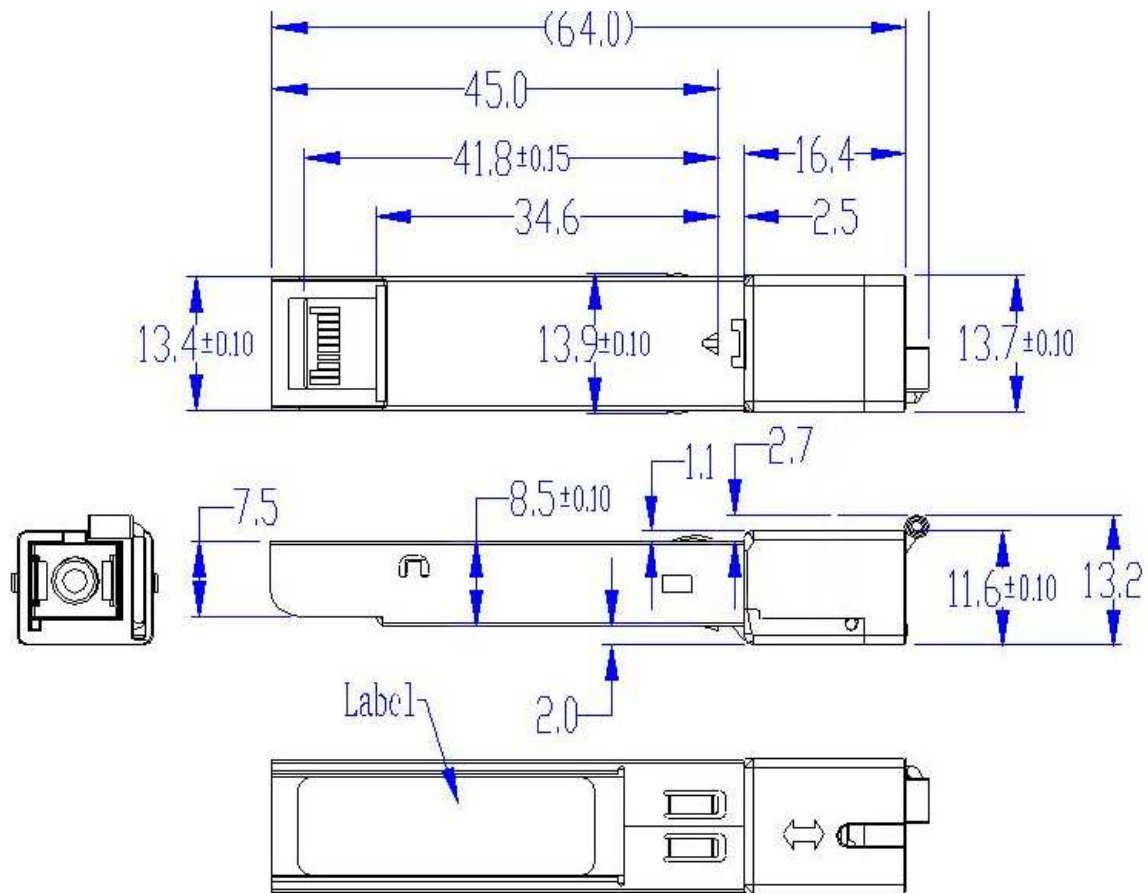

Figure 9 Mechanical Diagram

Order Information

Table 10 – Order Information

Part No.	Application	Data Rate	Laser Source	Fiber Type
SPS-43-GB-P3-CDFC	1000BASE-PX20++ OLT Extended reach OLT	1.25Gb/s symmetric	1490nm DFB	SMF

Warnings

Handling Precautions: This device is susceptible to damage as a result of electrostatic discharge (ESD). A static free environment is highly recommended. Follow guidelines according to proper ESD procedures.

Laser Safety: Radiation emitted by laser devices can be dangerous to human eyes. Avoid eye exposure to direct or indirect radiation.

Legal Notice

IMPORTANT NOTICE!

All information contained in this document is subject to change without notice, at Source Photonics' sole and absolute discretion. Source Photonics warrants performance of its products to current specifications only in accordance with the company's standard one-year warranty; however, specifications designated as "preliminary" are given to describe components only, and Source Photonics expressly disclaims any and all warranties for said products, including express, implied, and statutory warranties, warranties of merchantability, fitness for a particular purpose, and non-infringement of proprietary rights. Please refer to the company's Terms and Conditions of Sale for further warranty information.

Source Photonics assumes no liability for applications assistance, customer product design, software performance, or infringement of patents, services, or intellectual property described herein. No license, either express or implied, is granted under any patent right, copyright, or intellectual property right, and Source Photonics makes no representations or warranties that the product(s) described herein are free from patent, copyright, or intellectual property rights. Products described in this document are NOT intended for use in implantation or other life support applications where malfunction may result in injury or death to persons. Source Photonics customers using or selling products for use in such applications do so at their own risk and agree to fully defend and indemnify Source Photonics for any damages resulting from such use or sale.

THE INFORMATION CONTAINED IN THIS DOCUMENT IS PROVIDED ON AN "AS IS" BASIS. Customer agrees that Source Photonics is not liable for any actual, consequential, exemplary, or other damages arising directly or indirectly from any use of the information contained in this document. Customer must contact Source Photonics to obtain the latest version of this publication to verify, before placing any order, that the information contained herein is current.

Contact

U.S.A. Headquarters

20550 Nordhoff Street
Chatsworth, CA 91311
USA

Tel: +1-818-773-9044

Fax: +1-818-773-0261

sales@sourcephotonics.com

China

Building #2&5, West Export Processing Zone
No. 8 Kexin Road, Hi-Tech Zone
Chengdu, 611731, China

Tel: +86-28-8795-8788

Fax: +86-28-8795-8789

sales@sourcephotonics.com.cn

Taiwan

9F, No 81, Shui Lee Rd.
Hsinchu, 300, Taiwan
R.O.C.

Tel: +886-3-5169222

Fax: +886-3-5169213

sales@sourcephotonics.com.tw

© Copyright Source Photonics, Inc. 2007~2012

All rights reserved