



Features

- Compliant with CSFP MSA 2.0 (Option 2)
 - Burst receive GPON OLT transceiver
 - Small Form Factor Pluggable, Duplex LC Connector
 - "Fast Signal Detect" feature reduces ranging overhead
 - Simplified OLT "reset" timing
 - 1490 nm DFB Tx with isolator
 - 1310 nm APD Rx
 - 2488 Mbps downstream Tx/1244 Mbps upstream Rx
 - Single 3.3 V supply
 - ITU-T G.984.2 compliant
 - 20 km reach; 28 dB link budget
- Operating case temperature: -5~70°C
- RoHS compliant (lead exemption)

General Parameters

Parameter	Minimum	Typical	Maximum	Unit/Conditions
Operating Voltage, Vcc	3.135	3.3	3.465	V
Total Current, Icc	-	-	800	mA
Case Operating Temperature	-5	-	70	°C
Storage Temperature	-40	-	85	°C

Parameter	Minimum	Typical	Maximum	Unit/Conditions
Back Reflection at 1490 nm	-	-	-20	dB
Back Reflection at 1310 nm	-	-	-20	dB
1490 nm to 1310 nm Crosstalk	-	-	-45	dB

Functional Characteristics

The following tables list the performance specifications for the various functional blocks of the integrated optical transceiver module.

Parameter	Minimum	Typical	Maximum	Unit	Notes
Average Optical Output Power, P_O	1.5	-	5	dBm	
Output Power at Transmit Off	-	-	-40	dBm	
Extinction Ratio	8.2	-	-	dB	PRBS 2 ²³ -1, NRZ, 50% duty cycle
Transmitter Output Eye	G.984.2 Figure 2				
Optical Rise and Fall Time	-	-	160	ps	20% to 80%
Center Wavelength, λ	1480	1490	1500	nm	
-20 dB Spectral Width	-	-	1	nm	
Side Mode Suppression Ratio (SMSR)	30	-	-	dB	
Bit Rate	-	2488	-	Mbps	
Tolerance to TX Back Reflection ^a	-15	-	-	dB	

a) 1 dB degradation of Rx sensitivity

Parameter	Minimum	Typical	Maximum	Unit	Notes
Input Differential Impedance	80	100	120	Ω	
Single Ended Data Input Swing	-	750	-	mV	
Tx Disable (LVTTL)	2	-	V _{cc}	V	
Tx Enable (LVTTL)	0	-	0.8	V	
TX_Fail_High	2.4	-	V _{cc}	V	
TX_Fail_Normal	0	-	0.4	V	

Parameter	Minimum	Typical	Maximum	Unit	Notes
Operational Wavelength Range	1260	1310	1360	nm	
Data Rate (burst mode)	-	1244	-	Mbps	
Receiver Burst-Mode Sensitivity	-	-	-28	dBm	At 10 ⁻¹⁰ BER, PRBS 2 ²³ -1
Receiver Overload	-8	-	-	dBm	
Burst Detect Assert	-	-	-28	dBm	
Receiver Burst Mode Dynamic Range	15	-	-	dB	Input power difference between two subsequent high and low burst data
Damage Threshold for Receiver	+3	-	-	dBm	
Maximum Reflectance of Receiver	-	-	-20	dB	

Table 6 – Receiver Specifications (Electrical)

Parameter	Minimum	Typical	Maximum	Unit	Notes
PECL Single Ended Data Output Swing (LVPECL)	-	750	-	mV	
Data Output Rise Time	-	-	300	ps	20% to 80%
Data Output Fall Time	-	-	300	ps	20% to 80%
Signal Detect Output HIGH	2.4	-	V _{cc}	V	
Signal Detect Output LOW ^a	0	-	0.4	V	
Signal Detect Assert Time	-	-	100	ns	
Signal Detect De-Assert Time	-	-	12.8	ns	

a) Signal Detect assert low when module receive “reset” signal, assert high when incoming burst is detected and latch to high state until next “Reset” signal.

Table 7 – Digital RSSI Timing Specification

Parameter	Minimum	Typical	Maximum	Unit	Notes
RSSI Trigger Delay ^a	25	-	-	ns	
RSSI Sampling Time ^a	300	-	-	ns	
Internal I ² C Delay ^a	-	-	500	us	
Receiver Power DDM (RSSI) Error ^b	-	-	+/- 3	dB	

a) RSSI_ACQ input signal rising edge will trigger RSSI sampling, and falling edge will trigger internal digital RSSI information written to I2C. It is recommended that host shall not trigger RSSI_ACQ input again until RSSI data is valid in I2C from previous RSSI trigger.

b) RSSI DDM working range is between -8 to -28 dBm. RSSI DDM accuracy is better than +/- 3dB for input power levels between -10 to -28 dBm under over temp, the accuracy reduces to +/- 2 dB for input power level larger between -8 to 10dBm under room temp.

Timing Diagram

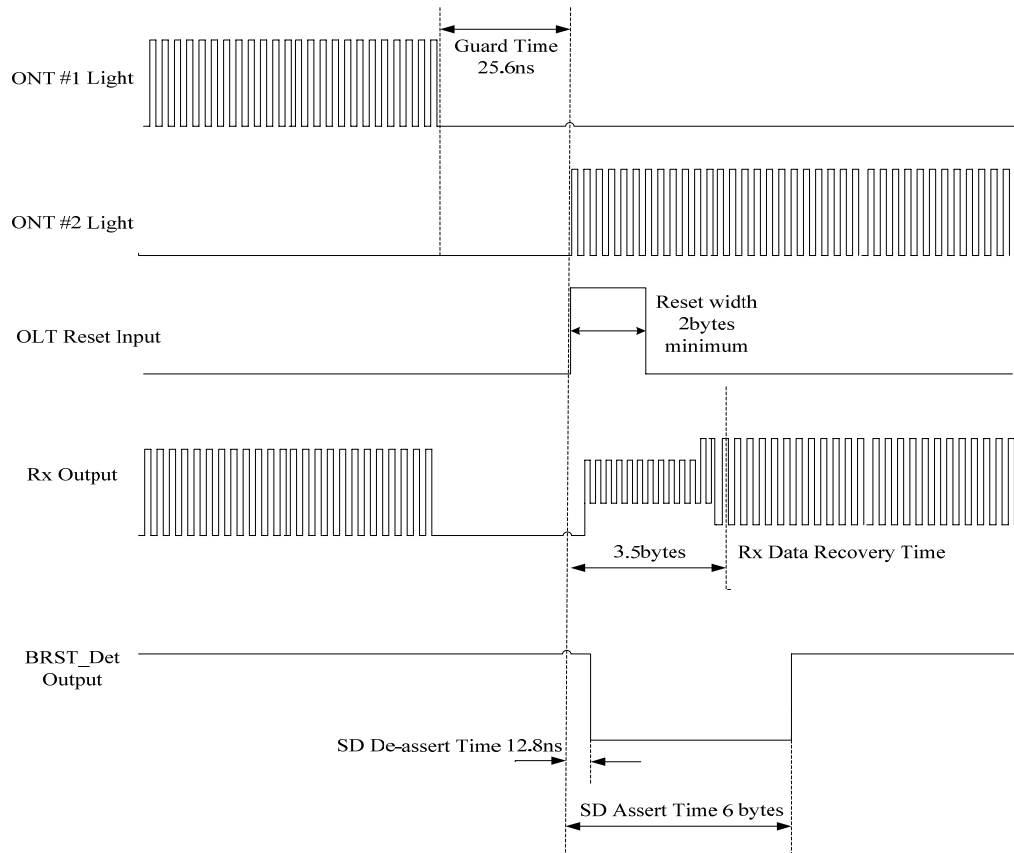

Figure 1. Timing Diagram

Digital RSSI Acquire/Hold Timing Specification

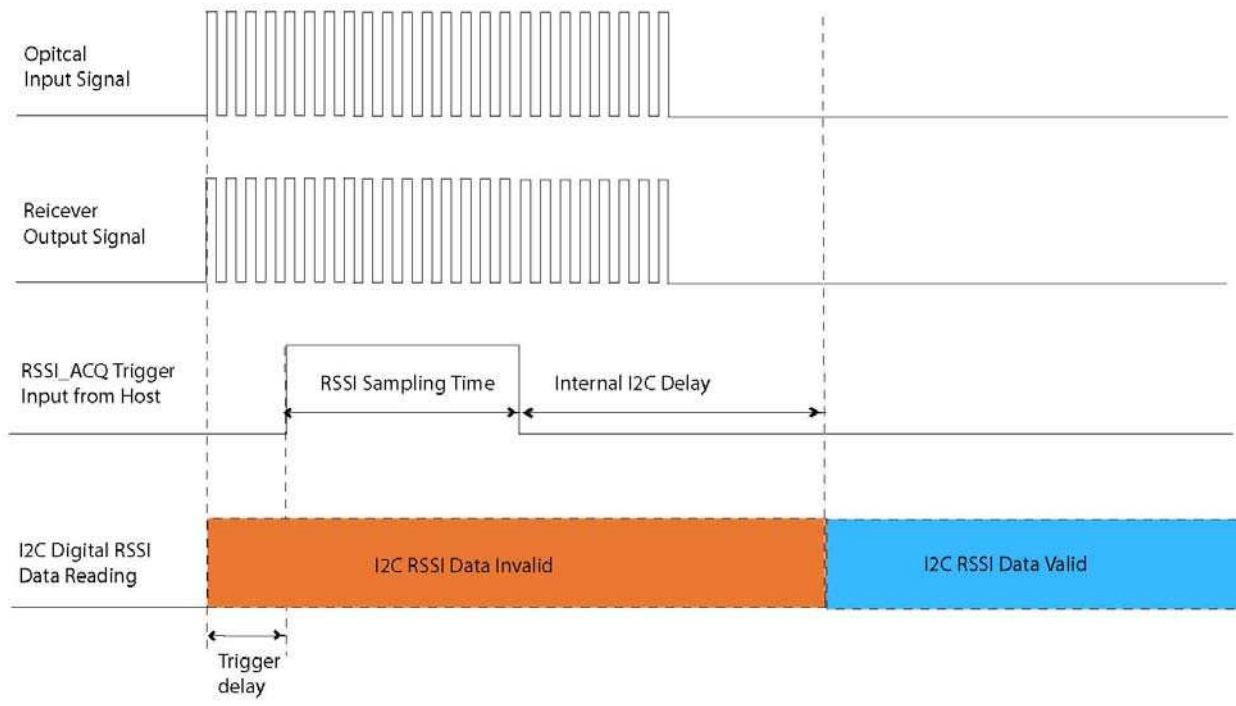

Figure 2. Digital RSSI Timing.

Pin Definitions

Refer to Table-8 for a description of the function of each I/O pin.

Pin Number	Label	Definition
1	Veet	Tx Ground
2	RX_SD2	Receiver Data Output of Ch2
3	Reset2	Reset of Ch2
4	SDA	2-Wire Serial Data I/O Pin. Transfers serial data to and from device
5	SCL	2-Wire Serial Clock Input. Clocks data into and out of the device.
6	RSSI_Trig2	RSSI Trigger Ch2
7	Reset1	Reset of Ch1
8	RX_SD1	Receiver Data Output of Ch1
9	RSSI_Trig1	RSSI_Trigger Ch1
10	TXD2+	Transmit Data Input of Ch2
11	TXD2-	Invert Transmit Data Input of Ch2
12	RXD1-	Inverted Receiver Data Output of Ch1
13	RXD1+	Receiver Data Output Ch1
14	RXD2-	Inverted Receiver Data Output of Ch2
15	Vcc_Rx	Rx Vcc
16	Vcc_Tx	Tx Vcc
17	RXD2+	Receiver Data Output Ch2
18	TXD1+	Transmit Data Input of Ch1
19	TX1D-	Invert Transmit Data Input of Ch1
20	Veet	Tx Ground

EEPROM Information

Table 9 – EEPROM Content (A0h/B0h)

I2C A0h/B0h Address					
DEC Addr.	HEX Addr.	Field Size (bytes)	Name	Default Value	Description
0	00	1	Identifier	03h	SFP transceiver
1	01	1	Extended Identifier	04h	mod4
2	02	1	Connector	07h	LC
3	03	8	Transceiver	11 13 00 00 00 00 00 08h	BASE-PX
11	0B	1	Encoding	03h	NRZ
12	0C	1	Nominal Bit Rate in 100 MBps	19h	2488.32Mbps
13	0D	1	Reserved	00h	Reserved
14	0E	1	Length (9μ, km) in km	14h	20km
15	0F	1	Length (9μ, m) in 100 m	C8h	20km
16	10	1	Length (50μ) in 10 m	00h	Not Supported
17	11	1	Length (62.5μ) in 10 m	00h	Not Supported
18	12	1	Length (Copper) in m	00h	Not Supported
19	13	1	Reserved	00h	Reserved
20	14	16	Vendor Name (ASCII)	"SOURCE PHOTONICS"	Vendor Name (ASCII)
36	24	1	Reserved	00h	Reserved
37	25	3	Vender IEEE Company ID	00 1F 22h	vendor IEEE ID
40	28	16	Vendor Part Number (ASCII)	"SPLC-43-48H-HP-CDE"	Vendor Part Number (ASCII)
56	38	4	Vendor Rev (ASCII)	30 31 20 20	Revision
60	3C	2	Laser Wavelength in nm	05 D2h	1490nm Tx Wavelength
62	3E	1	Reserved	00h	Reserved
63	3F	1	Check Code for Base ID Fields	xxh	Checksum from byte 0-62
64	40	2	Options	00 1Ch	SD, TX_Fault, TX_DIS
66	42	1	Upper Bit Rate Margin in %	00h	BR, Max not specified
67	43	1	Lower Bit Rate Margin in %	00h	BR, Min not specified
68	44	16	Vendor Serial Number (ASCII)	"xxxxxxxxxxxxxxxx"	16 byte Serial number field (ASCII)

84	54	8	Date Code	xx xx xx xx xx xx 20 20h	Year(2 bytes) month(2 bytes) day(2 bytes)
92	5C	1	Diagnostic Monitoring Type	58	External Calibration, Average Power Measurement
93	5D	1	Enhanced Options	E0h	Optical Alarm/warning implemented Soft TX_DIS, TX_FAULT implemented
94	5E	1	SFF-8472 Compliance	02h	Compliance to SFF-8472
95	5F	1	Check Code for Extended ID Fields	xxh	Checksum from byte 64-69
96	60	30	Vendor Specific		
126	7E	2	Vendor Specific		
128	80	128	Reserved		

Note: The "xx" byte should be filled in according to practical case. For more information, please refer to the related document of SFF-8472 Rev 9.5.

Table 10 – EEPROM Content (A2h/B2h)

I2C A2h/B2h Address

DEC Addr.	HEX Addr.	Field Size (bytes)	Name	Default Value	Description
0	00	2	Temp High Alarm	50 00h	80°C
2	02	2	Temp Low Alarm	F3 00h	-13°C
4	04	2	Temp High Warning	4B 00h	75°C
6	06	2	Temp Low Warning	F8 00h	-8°C
8	08	2	Voltage High Alarm	8C A0h	3.6V
10	0A	2	Voltage Low Alarm	75 30h	3V
12	0C	2	Voltage High Warning	88 B8h	3.5V
14	0E	2	Voltage Low Warning	79 18h	3.1V
16	10	2	Bias High Alarm	B9 8Ch	95mA
18	12	2	Bias Low Alarm	03 E8h	2mA
20	14	2	Bias High Warning	A6 04h	85mA
22	16	2	Bias Low Warning	09 C4h	5mA
24	18	2	TX Power High Alarm	8A 99h	5.5dBm
26	1A	2	TX Power Low Alarm	2B D4h	0.5dBm
28	1C	2	TX Power High Warning	7B 86h	5dBm
30	1E	2	TX Power Low Warning	31 2Dh	1dBm

32	20	2	RX Power High Alarm	1F 2Dh	-7dBm
34	22	2	RX Power Low Alarm	00 28h	-30 dBm
36	24	2	RX Power High Warning	18 C3h	-8 dBm
38	26	2	RX Power Low Warning	00 32h	-29 dBm
40	28	16	Reserved	00....000h	Reserved
56	38	4	RX_PWR(4) Calibration	00 00 00 00h	4th order RSSI calibration coefficient
60	3C	4	RX_PWR(3) Calibration	00 00 00 00h	3rd order RSSI calibration coefficient
64	40	4	RX_PWR(2) Calibration	00 00 00 00h	2nd order RSSI calibration coefficient
68	44	4	RX_PWR(1) Calibration	3E 80 00 00h	1st order RSSI calibration coefficient
72	48	4	RX_PWR(0) Calibration	00 00 00 00h	0th order RSSI calibration coefficient
76	4C	2	TX_I(Slope) Calibration	01 00h	Slope for Bias calibration
78	4E	2	TX_I(Offset) Calibration	00 00h	Offset for Bias calibration
80	50	2	TX_PWR(Slope) Calibration	01 00h	Slope for TX Power calibration
82	52	2	TX_PWR(Offset) Calibration	00 00h	Offset for TX Power calibration
84	54	2	T(Slope) Calibration	01 00h	Slope for Temperature calibration
86	56	2	T(Offset) Calibration	00 00h	Offset for Temperature calibration, in units of 256ths C
88	58	2	V(Slope) Calibration	01 00h	Slope for VCC calibration
90	5A	2	V(Offset) Calibration	00 00h	Offset for VCC calibration
92	5C	3	Reserved	00h	reserved
95	5F	1	Checksum	xxh	Checksum
96	60	2	Transceiver Temperature	xx xxh	Temperature in C/256
98	62	2	Supply Voltage	xx xxh	Vcc
100	64	2	TX Bias Current	xx xxh	BIASMON
102	66	2	TX Optical Output Power	xx xxh	Back facet monitor
104	68	2	RX Optical Input Power	xx xxh	RSSI
106	6A	2	Reserved	0000h	Reserved
108	6C	2	Reserved	0000h	Reserved
110	6E.7	1bit	TX_DIS State	x	Digital state of the TX Disable Input Pin.
	6E.6	1bit	Soft TX Disable	x	Read/write bit that allows software disable of laser.
	6E.5	1bit	Reserved.	0	Reserved.
	6E.4	1bit	Rate Select State	0	NOT SUPPORTED.
	6E.3	1bit	Rate Select	0	NOT SUPPORTED.
	6E.2	1bit	TX_FAULT	x	Digital state of the TX Fault Output Pin.

	6E.1	1bit	LOS	0	Digital state of the LOS Output Pin. NOT SUPPORTED
	6E.0	1bit	Data_ready_bar	x	Indicates transceiver has achieved power up and data is ready.
111	6F.7	1bit	Reserved	0	Reserved
	6F.6	1bit	Reserved	0	Reserved
	6F.5	1bit	Reserved	0	Reserved
	6F.4	1bit	Reserved	0	Reserved
	6F.3	1bit	Reserved	0	Reserved
	6F.2	1bit	INTERRUPT_NOT	x	Interrupt state (active low)
	6F.1	1bit	MODE_EN	0	TX FAULT pin enable
	6F.0	1bit	APD_SHUTDOWN	x	APD shut-down latch. Write 0 to clear condition
112	70.7	1bit	Temperature too high alarm	x	Temperature too high alarm
	70.6	1bit	Temperature too low alarm	x	Temperature too low alarm
	70.5	1bit	VCC too high alarm	x	VCC too high alarm
	70.4	1bit	VCC too low alarm	x	VCC too low alarm
	70.3	1bit	BIASMON too high alarm	x	BIASMON too high alarm
	70.2	1bit	BIASMON too low alarm	x	BIASMON too low alarm
	70.1	1bit	BFMON too high alarm	x	BFMON too high alarm
	70	1bit	BFMON too low alarm	x	BFMON too low alarm
113	71.7	1bit	RSSI too high alarm	x	RSSI too high alarm
	71.6	1bit	RSSI too low alarm	x	RSSI too low alarm
	71.5	1bit	Reserved interrupt status bit	x	Reserved interrupt status bit
	71.4	1bit	Reserved interrupt status bit	x	Reserved interrupt status bit
	71.3	1bit	Reserved interrupt status bit	x	Reserved interrupt status bit
	71.2	1bit	Reserved interrupt status bit	x	Reserved interrupt status bit
	71.1	1bit	Reserved interrupt status bit	x	TX Fail went HIGH
	71	1bit	Reserved interrupt status bit	x	APD Shutdown event detected
114	72	1	Reserved	00h	Interrupt Mask for ISRC0

115	73	1	Reserved	00h	Interrupt Mask for ISRC1
116	74.7	1bit	Temperature too high warning	x	Temperature too high warning
	74.6	1bit	Temperature too low warning	x	Temperature too low warning
	74.5	1bit	VCC too high warning	x	VCC too high warning
	74.4	1bit	VCC too low warning	x	VCC too low warning
	74.3	1bit	BIASMON too high warning	x	BIASMON too high warning
	74.2	1bit	BIASMON too low warning	x	BIASMON too low warning
	74.1	1bit	BFMON too high warning	x	BFMON too high warning
	74	1bit	BFMON too low warning	x	BFMON too low warning
117	75.7	1bit	RX Power High Warning	x	RSSI too high warning
	75.6	1bit	RX Power Low Warning	x	RSSI too low warning
	75.5	1bit	Reserved	0	Reserved
	75.4	1bit	Reserved	0	Reserved
	75.3	1bit	Reserved	0	Reserved
	75.2	1bit	Reserved	0	Reserved
	75.1	1bit	Reserved	0	Reserved
	75	1bit	Reserved	0	Reserved
118	76	1	Reserved	00h	Interrupt Mask for ISRC2
119	77	1	Reserved	00h	Interrupt Mask for ISRC3
120	78	8	Vendor Specific	00 00 00 00 00 00 00 00h	Vendor Specific

Table 11 – Digital Diagnostic Specification (A2h for channel 1, B2h for channel 2)

Data Address	Parameter	Range	Accuracy
96-97	Temperature	0 to +70°C	±3°C
98-99	Vcc Voltage	+3.0V to +3.6V	±3%
100-101	Bias Current	0 to 100mA	±10%
102-103	TX Power	0 to 6dBm	±2dB
104-105	RX Power	-28 to -8dBm	±3dB

Mechanical Diagram

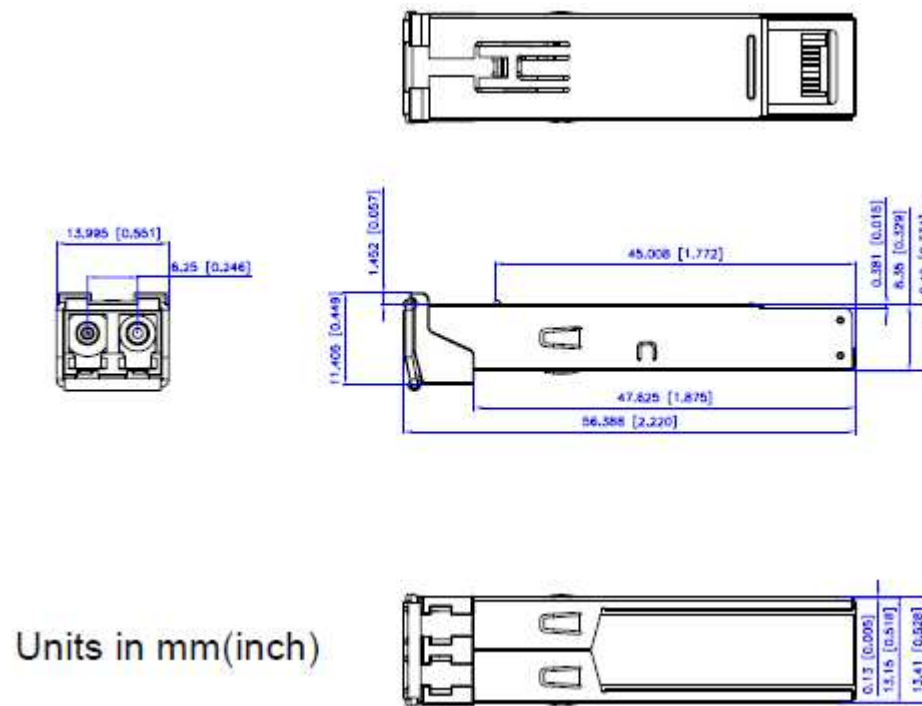

Figure 3. Mechanical Diagram.

Table 12 - Device Handling/ESD Protection

The devices are static sensitive and may easily be damaged if care is not taken during handling. The following handling practices are recommended.

1	Devices should be handled on benches with conductive and grounding surfaces.
2	All personnel, test equipment and tools shall be grounded.
3	Do not handle the devices by their leads.
4	Store devices in protective foam or carriers.
5	Avoid the use of non-conductive plastics, rubber, or silk in the area where the devices are handled
6	All modules shall be packaged in materials that are anti-static to protect against adverse electrical environments.
7	Avoid applications of any voltage higher than maximum rated voltages to this part. For proper operation, any VIN or VOUT should be constrained to the range $GND \leq (VIN \text{ or } VOUT) \leq VCC$. Unused inputs must always be tied to an appropriate logic voltage (e.g. either GND or VCC). Unused outputs must be left open.

Warnings

Handling Precautions: This device is susceptible to damage as a result of electrostatic discharge (ESD). A static free environment is highly recommended. Follow guidelines according to proper ESD procedures.

Laser Safety: Radiation emitted by laser devices can be dangerous to human eyes. Avoid eye exposure to direct or indirect radiation.

Legal Notice

IMPORTANT NOTICE!

All information contained in this document is subject to change without notice, at Source Photonics' sole and absolute discretion. Source Photonics warrants performance of its products to current specifications only in accordance with the company's standard one-year warranty; however, specifications designated as "preliminary" are given to describe components only, and Source Photonics expressly disclaims any and all warranties for said products, including express, implied, and statutory warranties, warranties of merchantability, fitness for a particular purpose, and non-infringement of proprietary rights. Please refer to the company's Terms and Conditions of Sale for further warranty information.

Source Photonics assumes no liability for applications assistance, customer product design, software performance, or infringement of patents, services, or intellectual property described herein. No license, either express or implied, is granted under any patent right, copyright, or intellectual property right, and Source Photonics makes no representations or warranties that the product(s) described herein are free from patent, copyright, or intellectual property rights. Products described in this document are NOT intended for use in implantation or other life support applications where malfunction may result in injury or death to persons. Source Photonics customers using or selling products for use in such applications do so at their own risk and agree to fully defend and indemnify Source Photonics for any damages resulting from such use or sale.

© Copyright Source Photonics, Inc. 2008-2014

All Rights Reserved.

All information contained in this document is subject to change without notice. The products described in this document are NOT intended for use in implantation or other life support applications where malfunction may result in injury or death to persons.

The information contained in this document does not affect or change Source Photonics product specifications or warranties. Nothing in this document shall operate as an express or implied license or indemnity under the intellectual property rights of Source Photonics or third parties. All information contained in this document was obtained in specific environments, and is presented as an illustration. The results obtained in other operating environments may vary.

THE INFORMATION CONTAINED IN THIS DOCUMENT IS PROVIDED ON AN "AS IS" BASIS. In no event will Source Photonics be liable for damages arising directly from any use of the information contained in this document.

Contact

SOURCE PHOTONICS
20550 NORDHOFF ST.
CHATSWORTH, CA 91311

sales@sourcephotonics.com

Tel: 818-773-9044 Fax: 818-576-9486

Or visit our website: <http://www.sourcephotonics.com>