



Features

- Support ITU-T G.987.2 XGPON OLT N2a class side application
- Single fiber bi-directional data links with asymmetric 9.953Gbps downstream and 2.488Gbps upstream
- Integrated with micro-optics WDM filter for dual wavelength Tx/Rx operation at 1577nm/1270nm
- 1577nm continuous-mode transmitter with EML laser
- 1270nm burst-mode receiver with APD-TIA
- 2-wire interface for integrated Digital Diagnostic Monitoring
- Digital Receiving Signal Strength Indication (RSSI)
- XFP MSA package with SC receptacle optical interface
- +3.3V power supplies
- Operating case temperature: -5~70°C
- RoHS compliance

Regulatory Compliance

Table 1 - Regulatory Compliance

Feature	Standard	Performance
Electrostatic Discharge (ESD) to the Electrical Pins	MIL-STD-883E Method 3015.7	Class 1(>500 V)
Electromagnetic Interference (EMI)	FCC Part 15 Class B EN55022 Class B (CISPR 22B) VCCI Class B	Compatible with standards
Immunity	IEC 61000-4-3	Compatible with standards
Laser Eye Safety	FDA 21CFR 1040.10 and 1040.11 EN60950, EN (IEC) 60825-1,2	Compatible with Class1 laser product.
Component Recognition	UL and CSA	Compliant with standards
RoHS	2002/95/EC 4.1&4.2 2005/747/EC	Compliant with standards ^{note}

Note:

In light of item 5 in Annex of 2002/95/EC, "Pb in the glass of cathode ray tubes, electronic components and fluorescent tubes." and item 13 in Annex of 2005/747/EC, "Lead and cadmium in optical and filter glass.", the two exemptions are being concerned for Source Photonics transceivers, because Source Photonics transceivers use glass, which may contain Pb, for components such as lenses, windows, isolators, and other electronic components electronic components.

Absolute Maximum Ratings

Table 2 - Absolute Maximum Ratings

Parameter	Symbol	Min.	Typical	Max.	Unit	Notes
Storage Ambient Temperature	T_S	-40	-	+85	°C	
Operating Case Temperature	T_C	-5		70	°C	1
Supply Voltage	V_{CC3}	-0.5	-	+4.0	V	
Operating Relative Humidity	RH	-	-	+85	%	
Damage Threshold for Receiver	$P_{IN-Damage}$	-	-	5	dBm	

Note 1: when ambient temperature is above 60°C, airflow at rate higher than 1m/sec is required

Recommended Operating Conditions

Table 3 – Recommended Operating Conditions

Parameter	Symbol	Min.	Typical	Max.	Unit	Notes
Operating Case Temperature	T_C	-5	-	70	°C	
Power Supply Voltage	V_{CC}	3.14	3.3	3.46	V	
Power Supply Current	I_{CC}	-	-	1000	mA	

Optical Characteristics

Table 4 – Optical Characteristics

Transmitter						
Parameter	Symbol	Min.	Typical	Max.	Unit	Notes
Centre Wavelength	λ_C	1575		1580	nm	
Spectral Width (-20dB)	$\Delta\lambda$			1	nm	
Side Mode Suppression Ratio	SMSR	30			dB	
Average Launch Power	P_{OUT}	4		8	dBm	1
Average Launch Power-OFF	P_{OFF}			-39	dBm	
Extinction Ratio	EX	7			dB	2
Optical Return Loss Tolerance		-15			dB	
Transmitter and dispersion Penalty	TDP			1	dB	3
Optical Eye Mask	Compliant With ITU-T G.987.2					
Receiver						
Operating Wavelength	λ_C	1260		1280	nm	

Sensitivity	P_{SEN}			-29.5	dBm	4
Saturation	P_{SAT}	-9			dBm	
Loss of Signal Deassert Level	P_{LOSD}			-30.5	dBm	5
Loss of Signal Assert Level	P_{LOSA}	-39			dBm	6
Hysteresis	$P_{SDD} - P_{SDA}$	0.5		5	dB	
Receiver Reflectance				-20	dB	

Notes:

1. The optical power is launched into 9/125um SMF.
2. Measured with PRBS $2^{31}-1$ test pattern @9.95328Gbps.
3. Maximum sensitivity penalty due to transmitter and dispersion effect through longer than 20km, for example 40km, of SMF optical fiber. Default is 20km.
4. Measured with a PRBS $2^{23}-1$ test pattern @2.488Gbps and ER=8.2dB, BER = 10^{-4} .
5. Increases in optical power below the specified level will cause loss of signal detected deassert output to switch from a low state to a high state.
6. Decreases in optical power below the specified level will cause loss of signal detected assert output to switch from a high state to a low state.

Electrical Characteristics

Table 5 – Electrical Characteristics

Transmitter						
Parameter	Symbol	Min.	Typical	Max.	Unit	Notes
Data Input Differential Swing	V_{IN}	120	-	820	mVp-p	1
Input Differential Impedance	Z_{IN}	80	100	120	Ω	
TX Disable Voltage	V_{IL}	0	-	0.8	V	2
	V_{IH}	2.0	-	V_{CC}	V	
Receiver						
Data Output Voltage - Low	V_{OL}	$V_{CC}-0.02$	$V_{CC}-0.005$	V_{CC}	V	
Data Output Voltage - High	V_{OH}	$V_{CC}-0.475$	$V_{CC}-0.4$	$V_{CC}-0.35$	V	
Data Output Differential Swing	V_{OUT}	600	800	1000	mVP-P	3
Loss of Signal Output Voltage - Low	$V_{LOS,L}$	0		0.4	V	4
Loss of Signal Output Voltage– High	$V_{LOS,H}$	2.4		V_{CC3}	V	
Loss of Signal Assert Time	T_{LOSA}			350	ns	
Loss of Signal Deassert Time	T_{LOSD}			250	ns	
Data Output Rise Time	T_r			140	ps	5
Data Output Fall Time	T_f			140	ps	
Receiver Settling Time	$T_{settling}$			140	ns	6

RSSI Trigger Delay	T _{trigger}	25			ns	7
RSSI Sampling Time	T _{sampling}		600		ns	8
Internal I ² C Delay	T _{I2C}			500	ms	

Notes:

1. Compatible with CML input, AC coupled internally. (See [Recommended Interface Circuit](#))
2. TX Disable (See [Pin Function Definitions](#)).
3. CML output, DC coupled internally, guaranteed in the full range of input optical power (-11dBm to -27.5dBm) (See [Recommended Interface Circuit](#)).
4. LOS (See [Pin Function Definitions](#)).
5. Amount time is from the reset signal is coming to the bust signal reaches a appropriate value
6. Test at 0101 pattern@2.5Gbps, 20% to 80% full swing
7. Falling edge of reset signal should be after the rising edge of the first preamble bit, test@1010 pattern
8. RSSI Input signal rising edge will trigger RSSI sampling, and falling edge will trigger internal digital RSSI information written to I2C. It is recommended that host shall not trigger RSSI input again until RSSI data is valid in I2C from previous RSSI trigger.

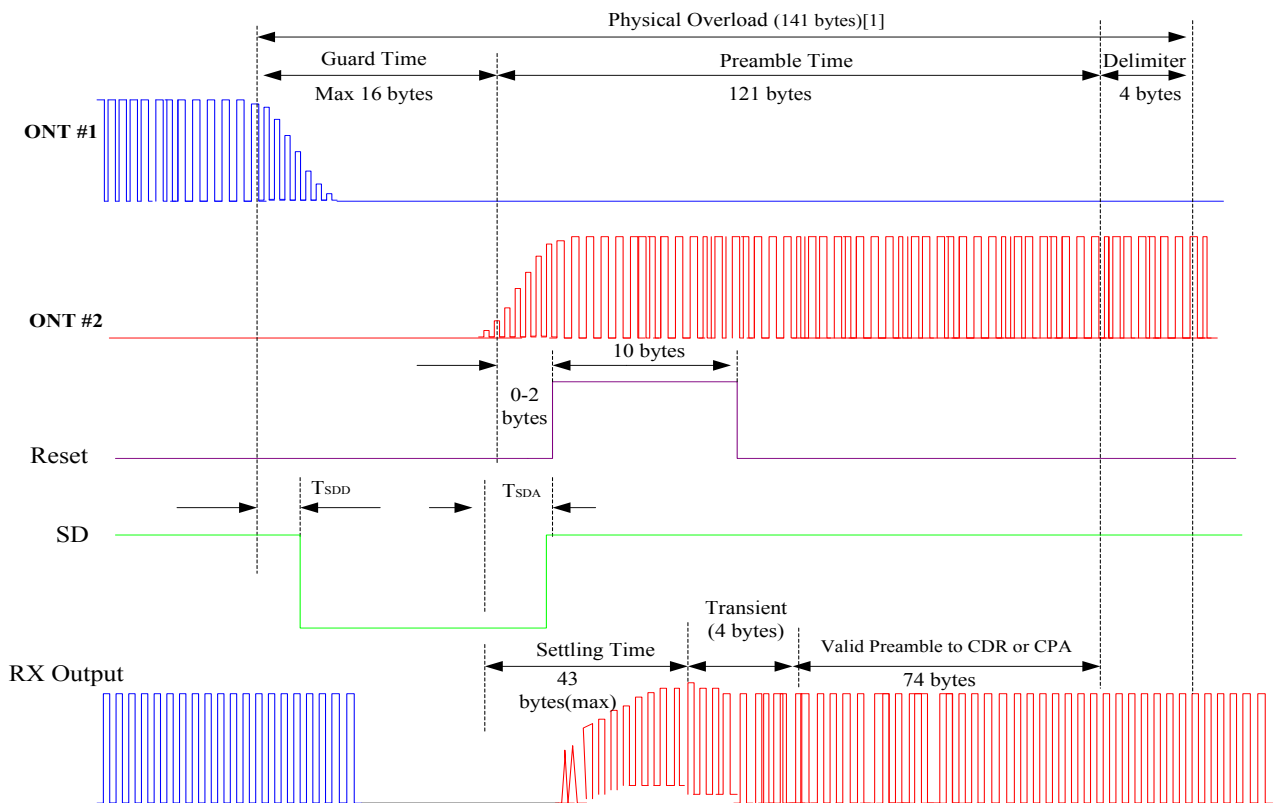

Note:

The bytes means that ONT rate is 2.488Gbps, 1bytes=3.2ns

Figure 1, Timing Parameter Definition in Burst Mode Sequence (Dual ONT Application)

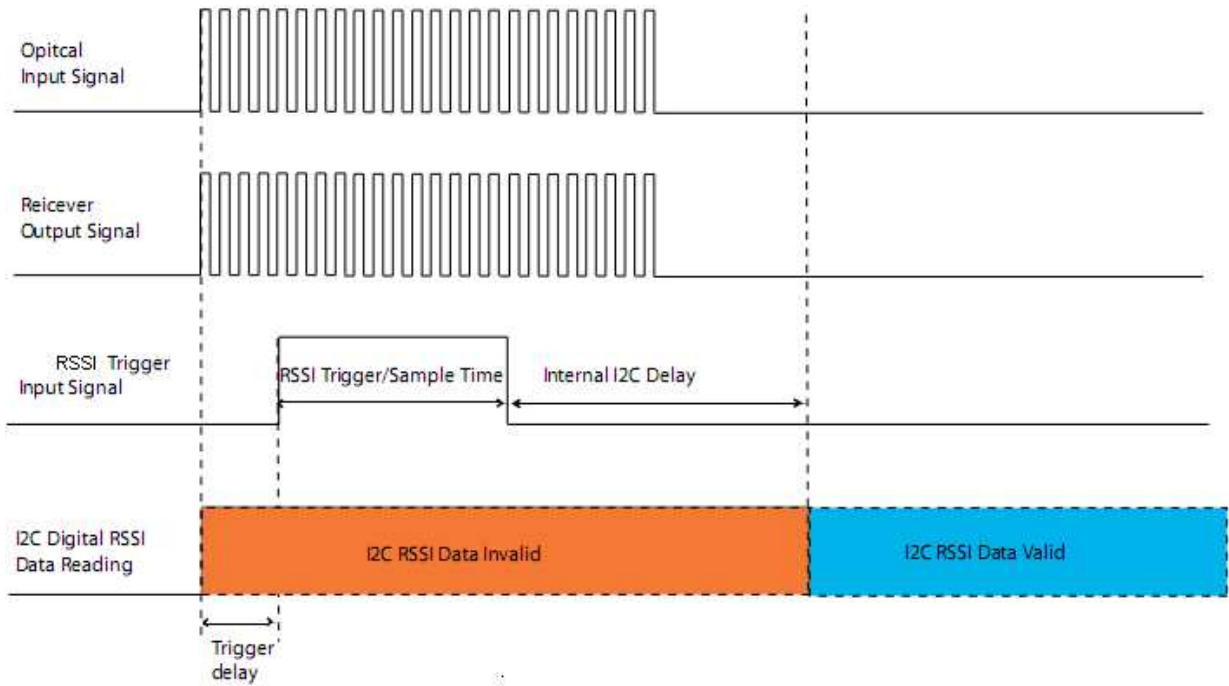

Figure 2, RSSI Timing Specification

Recommended Host Board Power Supply Circuit

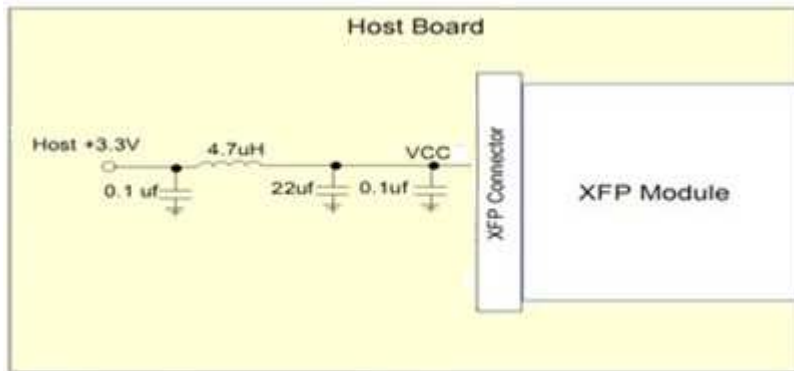

Figure 3, Recommended Host Board Power Supply Filtering Network

Recommended Interface Circuit

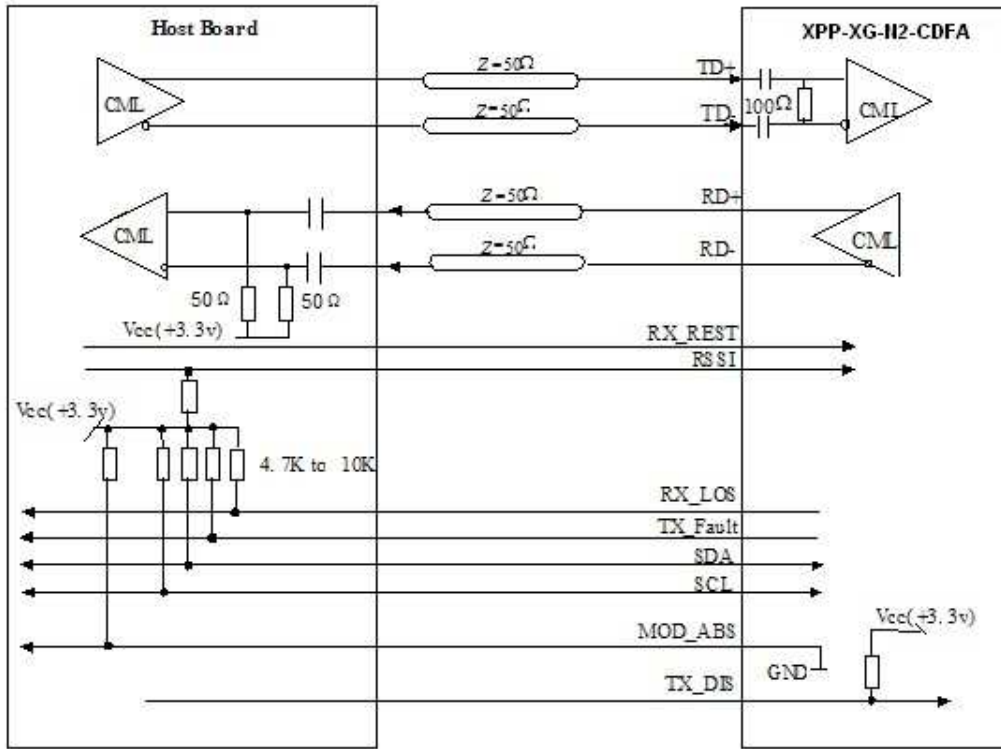

Figure 4, Recommended Interface Circuit

Pin Definitions

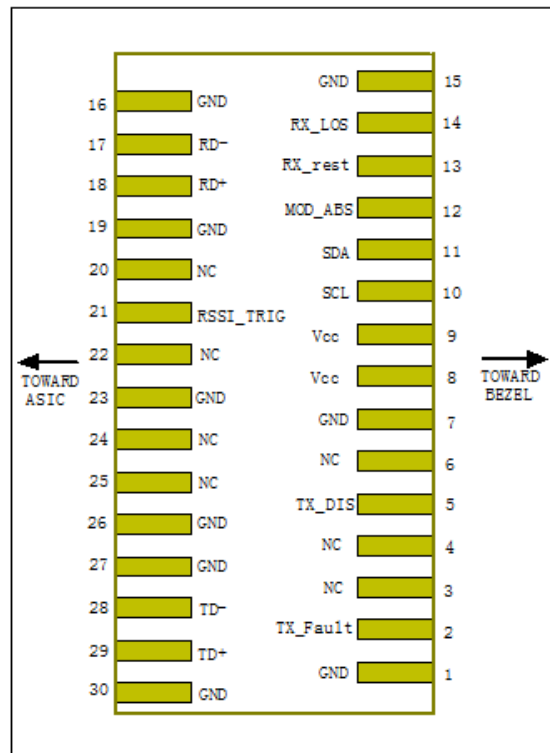

Figure5, XFP Pin View (Golden Finger)

Table 6 –Pin Function Definitions

Pin	Logic	Symbol	Name/Description	Note
1		GND	Module Ground	1
2	LVTTL-O	TX_FAULT	Transmitter fault Indication, low active	
3		NC	Not Connect	
4		NC	Not Connect	
5	LVTTL-I	TX_DIS	Turns off transmitter laser output, low active	2
6		NC	Not Connect	
7		GND	Module Ground	1
8		VCC3	+3.3V Power Supply	
9		VCC3	+3.3V Power Supply	
10	LVTTL-I/O	SCL	2-Wire Serial Interface Clock	
11	LVTTL-I/O	SDA	2-Wire Serial Interface Data Line	
12	LVTTL-O	Mod_ABS	Indicates Module is present. Grounded in the Module	
13	LVTTL-I	RX_Reset	Burst Module Reset Signal, high active	
14	LVTTL-O	RX_LOS	RX Loss of Signal Monitor, high active	
15		GND	Module Ground	1
16		GND	Module Ground	1
17	CML-O	RD-	Receiver Inverted Data Output	3
18	CML-O	RD+	Receiver Non-Inverted Data Output	
19		GND	Module Ground	1
20		NC	Not connect	
21	LVTTL-I	RSSI_TRIG	RSSI trigger signal, high active	
22		NC	Not connect	1
23		GND	Module Ground	1
24		NC	Not connect	
25		NC	Not connect	
26		GND	Module Ground	1
27		GND	Module Ground	1
28	CML-I	TD-	Transmitter Inverted Data Input	4
29	CML-I	TD+	Transmitter Non-Inverted Data Input	
30		GND	Module Ground	1

Notes:

1. Module ground pins GND are isolated from the module case and chassis ground within the module.
2. TX_Disable is an input that is used to shut down the transmitter optical output. It is pulled up within the module with a 4.7-10 K Ω resistor.
3. These are the differential receiver outputs. They are DC coupled is done inside the module (See

[Recommended Interface Circuit](#)

4. These are the differential transmitter inputs. They are AC coupled differential lines with 100Ω differential termination inside the module. The AC coupling is done inside the module and is thus not required on the host board. (See [Recommended Interface Circuit](#))

Diagnostics

Table 7– Diagnostics

Address(A0h)	Parameter	Range	Accuracy	Unit	Notes
96	Temperature	-5 to 70	±3	°C	
100	Bias Current	5 to 150	±10%	mA	LSB equal to 4uA
102	Tx Power	2 to 8	±3	dBm	LSB equal to 0.1uW
104	Rx Power	-30 to -8	±3	dBm	LSB equal to 0.1uW
106	Voltage	0 to Vcc	±3%	V	

Table 8– EEPROM Serial ID (A0h)

Name of Field	Description of Field	Address	Hex	ASCII
Identifier	Type of transceiver	128	06	XFP
Ext. Identifier	Extended identifier of type of transceiver	129	E8	>3.5W max power dissipation; with CDR
Connector	Code for connector type	130	01	SC/UPC
Transceiver	Code for electronic compatibility or optical compatibility	131	00	10GBASE-EW
		132	10	
		133	00	
		134	00	
		135	00	
		136	00	
		137	00	
138	00			
Encoding	Code for high speed serial encoding algorithm	139	10	NRZ
BR_MIN	Minimum bit rate, units of 100 Mbits/s.	140	63	9.95Gbps
BR_MAX	Maximum bit rate, units of 100 Mbits/s	141	63	9.95Gbps

Length (SMF)_Km	Link length supported for single mode fiber, units of km	142	14	Default is 20km,40km also support
Length (E-50um)	Link length supported for EBW 50/125 μm, units of 2 m	143	00	
Length (20μm)	Link length supported for 20 um OM2 fiber, units of 10 m	144	00	
Length (62.5μm)	Link length supported for 62.5 um OM1 fiber, units of 10 m	145	00	
Length (Copper)	Link length supported for copper, units of meters	146	00	
Device Tech		147	76	EML Laser and APD
Vendor Name	Vendor name (ASCII)	148	53	S
		149	4F	O
		150	55	U
		151	52	R
		152	43	C
		153	45	E
		154	50	P
		155	48	H
		156	4F	O
		157	54	T
		158	4F	O
		159	4E	N
		160	49	I
		161	43	C
162	53	S		
163	20	[Space]		

Table 9– EEPROM Serial ID (A2h)

Name of Field	Description of Field	Address	Hex	ASCII
CDR support	CDR Rate Support	164	F8	9.95-11.1Gbps
Vendor OUI	XFP vendor IEEE company ID for Source Photonics Inc.	165	00	
		166	1F	
		167	22	
Vendor PN	Part number in ASCII	168	58	X
		169	50	P
		170	50	P
		171	58	X
		172	47	G

		173	4E	N
		174	32	2
		175	43	C
		176	44	D
		177	46	F
		178	41	A
		179	20	[Space]
		180	20	[Space]
		181	20	[Space]
		182	20	[Space]
		183	20	[Space]
Vendor Rev.	Revision level for part number provide by vendor (ASCII)	184	30	01version
		185	31	
Wavelength	Laser wavelength, nm	186	7B	1577nm
		187	34	
Wavelength tolerance	Guaranteed range of laser wavelength (+/- value) from Nominal wave-length.	188	02	5nm
		189	58	
Max Case Temp	Maximum Case Temperature	190	55	85c
CC_BASE	Check code for Base ID Fields addresses (120-190)	191	xx	
Power Supply	Power supply current requirements and max power dissipation	192	AF	3.5W(max)
		193	00	
		194	AA	
		195	00	
Vendor SN	Serial number provided by vendor	196	xx xx xx xx	
Date Code	Vendor's manufacturing date code	212	xx xx xx xx xx xx xx xx	
Diagnostic Monitoring Type	Indicates which type of diagnostic monitoring is implemented	220	08	Average power
Enhanced Option	Indicates which optional enhanced features are implemented	221	40	Optional soft TX_Disable
AUX monitoring	Defines quantities reported by Aux. A/D channels	222	27	+3.3v power supply
CC_EXT	Check code for the Extended ID Fields (addresses 192 to 222)	223	xx	
Wavelength for 2.5G		224	63 38	1270nm
Wavelength for 1.25G		226	xx xx	

		227	58	
Vendor Spec.		228		

Mechanical Diagram

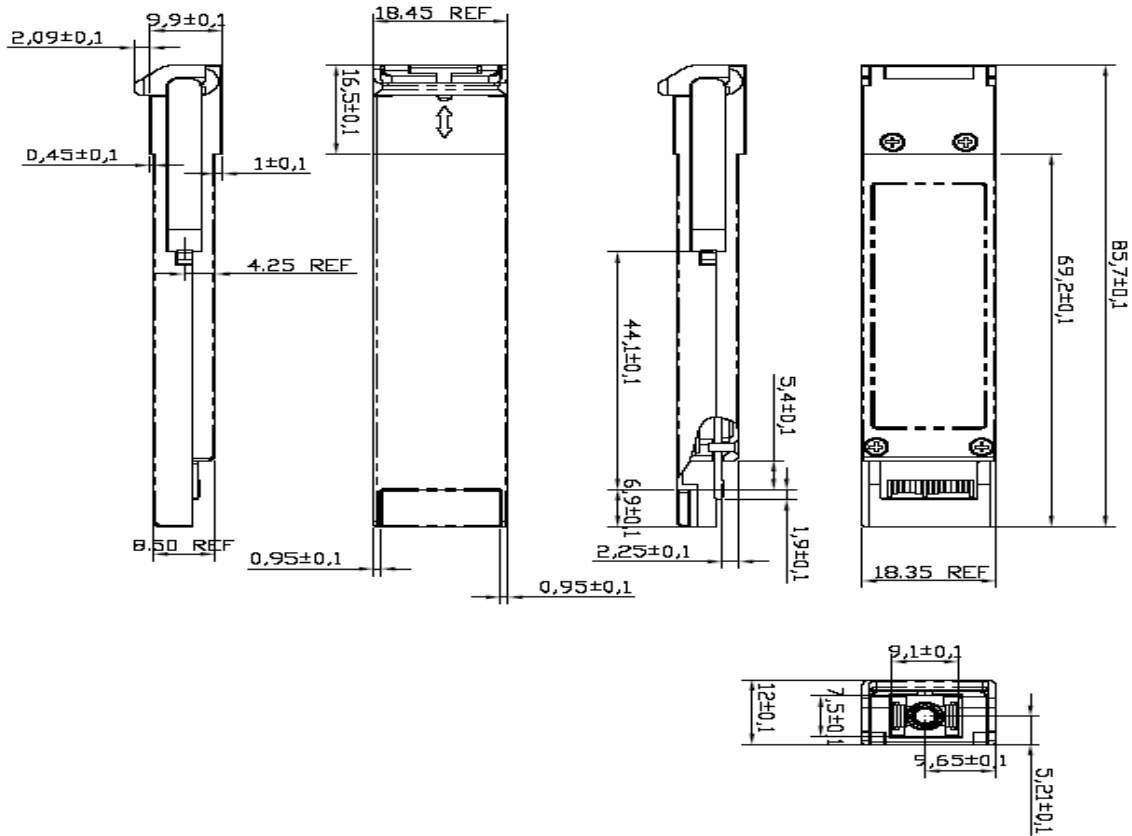

Figure 6, Mechanical Diagram

Order Information

Table 10– Order Information

Part No.	Application	Data Rate	Laser Source	Fiber Type
XPP-XG-N2-CDFA	XG-PON N2 Class	Tx:9.95328Gb/s Rx:2.44832Gb/s	1577nm EML	SMF

Warnings

Handling Precautions: This device is susceptible to damage as a result of electrostatic discharge (ESD). A static free environment is highly recommended. Follow guidelines according to proper ESD procedures.

Laser Safety: Radiation emitted by laser devices can be dangerous to human eyes. Avoid eye exposure to direct or indirect radiation.

Legal Notice

IMPORTANT NOTICE!

All information contained in this document is subject to change without notice, at Source Photonics' sole and absolute discretion. Source Photonics warrants performance of its products to current specifications only in accordance with the company's standard one-year warranty; however, specifications designated as "preliminary" are given to describe components only, and Source Photonics expressly disclaims any and all warranties for said products, including express, implied, and statutory warranties, warranties of merchantability, fitness for a particular purpose, and non-infringement of proprietary rights. Please refer to the company's Terms and Conditions of Sale for further warranty information.

Source Photonics assumes no liability for applications assistance, customer product design, software performance, or infringement of patents, services, or intellectual property described herein. No license, either express or implied, is granted under any patent right, copyright, or intellectual property right, and Source Photonics makes no representations or warranties that the product(s) described herein are free from patent, copyright, or intellectual property rights. Products described in this document are NOT intended for use in implantation or other life support applications where malfunction may result in injury or death to persons. Source Photonics customers using or selling products for use in such applications do so at their own risk and agree to fully defend and indemnify Source Photonics for any damages resulting from such use or sale.

THE INFORMATION CONTAINED IN THIS DOCUMENT IS PROVIDED ON AN "AS IS" BASIS. Customer agrees that Source Photonics is not liable for any actual, consequential, exemplary, or other damages arising directly or indirectly from any use of the information contained in this document. Customer must contact Source Photonics to obtain the latest version of this publication to verify, before placing any order, that the information contained herein is current.

Contact

U.S.A. Headquarters

20550 Nordhoff Street

Chatsworth, CA 91311

USA

Tel: +1-818-773-9044

Fax: +1-818-773-0261

China

Building #2&5, West Export Processing Zone

No. 8 Kexin Road, Hi-Tech Zone

Chengdu, 611731, China

Tel: +86-28-8795-8788

Fax: +86-28-8795-8789

Taiwan

9F, No 81, Shui Lee Rd.

Hsinchu, 300, Taiwan

R.O.C.

Tel: +886-3-5169222

Fax: +886-3-5169213

sales@sourcephotonics.com

sales@sourcephotonics.com.cn

sales@sourcephotonics.com.tw

© Copyright Source Photonics, Inc. 2007~2009

All rights reserved