



EP SERIES SAFETY LIMIT SWITCH

Description

The EP series safety limit switches conform to EN 50047 and have been developed to provide a range of options including plastic cases in various sizes, a choice of snap acting, slow break/make with 2 contact configurations and a choice of actuator heads. The ED series offers the option of rotating the head in 90° increments before installation to allow ease of mounting. Highly limit switches can be used in other applications other than guard doors, for example on moving machine beds, crane arms, lifts, elevators, etc.

Operation of these limit switches is achieved by the sliding action of the guard or other moving object deflecting the plunger or lever. For safety applications it is important that upon actuation, the guard or other moving objects should not pass completely over the switch and allow the plunger or lever to return to its original position.

Features

- Conforms to EN (TUV) standards corresponding to the CE marking
- Positive opening operation of NC (Normally Closed) contacts conforming to IEC /EN 60947-5-1 
- Double insulation makes ground terminal unnecessary (Bears  marking)
- Wide standard operating temperature range: -25° C to 80° C
- Full range of actuator heads and levers suitable for safety applications
- Sealing up to IP 67
- Wide switch variations, (Snap action and slow action basic switches)
- International conduit sizes



- BAUART GEPRÜFT
- TYPE APPROVED

Specifications

Standards	EN60947-5-1, UL508, EN50047, EN1088
Approvals	cULus, TUV and CE marked for all applicable directives
Positive Opening Operation	NC Contact
Utilization Category	AC15 A600
Min Current	5V, 5mA, DC
Thermal Current (Ith)	10A
Rated Insulation Voltage	600V AC
Rated Impulse withstand Volt	2500V AC
Insulation Resistance	100MΩ min. (DC 500V)
Contact Resistance	25mΩ max. (Initial)
Max Switching Speed	250mm/s
Max Switching Frequency	6000 operation per hour
Enclosure Material	UL approved glass-filled polybutylene terephthalate
Roller Material	Various polymers
Enclosure Protection	IP 67
Operating Temperature	Min -25°C (-18°F) Max 80°C (+176°F)
Pollution Degree	3
Protection Against Electric Shock	Class II (Double Insulation)
Mech. Life Expectancy	1 x 10 ⁷ Cycles min
Electrically Life Expectancy	150,000 Cycles min
Vibration	IEC 68-2-6, 10-55Hz ± 1 Hz, Excursion: 0.35mm, 1octave/min
Conduit Entry	Various (see Product Selection table)
Fixing	4 x M5

HIGHLY

A29

Design, specifications are subject to change without notice.

EP SERIES SAFETY LIMIT SWITCH

Structure Description

Metal Lever Setting

Grooves which engage the lever every 18° are cut in the operation indicator disk to prevent the lever from slipping against the rotary shaft.

Hand

With roller lever models, the direction of the switch head can be varied to any of the four directions by loosening the roller lever switch screws at the four corners of the head.

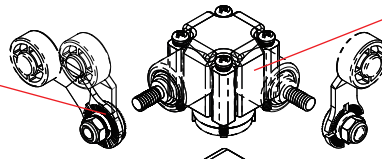

Contact Block

Wide switch variations.
Snap-action: 1NC/1NO
Slow-action: 1NC/1NO, 2NC, 2NC/1NO, 3NC

Conduit

Wide switch variations.
PG13.5
M20
1/2-14NPT

Cover

The cover, with a hinge on its lower part, can be opened by removing the screw of the cover, which ensures ease of maintenance and wiring.

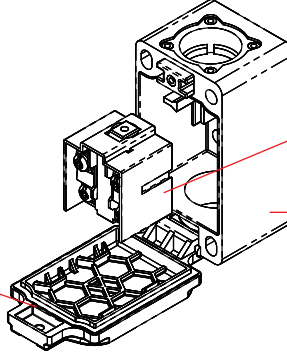

Product Selection

EP-□-□-□

1 2 3

1.THREAD DIMENSION OF LEAD EXIT

- 1: PG13.5 (s)
- 2: 1/2NPT (c)
- 6: M20 (O)
- 7: Connector (C)

2.CONTACT TYPES

- 1: 1NC/1NO SLOW ACTION (BBM)(S)
- 2: 2NC SLOW ACTION(O)
- 3: 1NC/1NO SNAP ACTION(C)
- 4: 2NC/1NO SLOW ACTION(S)
- 5: 3NC SLOW ACTION(S)

3.HEAD AND ACTUATOR

- 20: Roller arm type
- 21: Adjustable roller arm type (standard roller)
- 31: Push plunger type
- 32: Roller plunger type

*(s):standard (o):option (c): customization

Contact Block Form

TYPE	CONTACT FORM	CONNECTOR PIN ARRANGEMENT	OPERATION DIAGRAMS
EP-□-1-□□	1NC/1NO(Slow action) (See Note 1)		
EP-□-2-□□	2NC (Slow action) (See Note 2)		
EP-□-3-□□	1NC/1NO(Snap action) (See Note 1)		
EP-□-4-□□	3NC (Slow action)		No Connector TYPE
EP-□-5-□□	2NC/1NO(Slow action)		

HIGHLY

A30

Design, specifications are subject to change without notice.

EP SERIES SAFETY LIMIT SWITCH

Operating Characteristics

Unit: mm

Item

Operating Characteristics

Dimensions

EP-20

Roller Arm Type



(Only for slow action models.)

Type	Contact Block	Operating travel (PT)	PT2nd	Operating Force (OF)	Positive Opening		Total Travel
					Travel (min)	Force (min)	
EP-x-1-20	Slow 1NC/1NO	30°	41°	6.5 N	45°	19.0 N	80°
EP-x-2-20	Slow 2NC	30°	-	6.5 N			
EP-x-3-20	Snap 1NC/1NO	28°	-	5.3 N			
EP-x-4-20	Slow 2NC/1NO	30°	41°	6.5 N			
EP-x-5-20	Slow 3NC	30°	-	6.5 N			

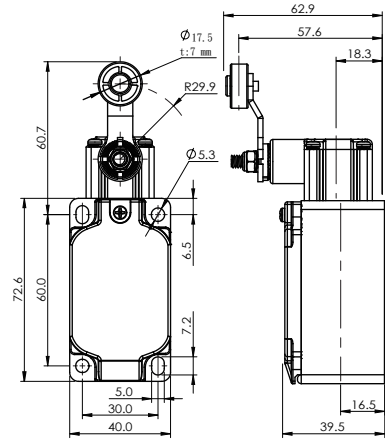

EP-21

Adjustable Roller Arm Type
(Standard arm)



(Only for slow action models.)

Type	Contact Block	Operating travel (PT)	PT2nd	Operating Force (OF)	Positive Opening		Total Travel
					Travel (min)	Force (min)	
EP-x-1-20	Slow 1NC/1NO	30°	41°	6.5 N	45°	19.0 N	80°
EP-x-2-20	Slow 2NC	30°	-	6.5 N			
EP-x-3-20	Snap 1NC/1NO	28°	-	5.3 N			
EP-x-4-20	Slow 2NC/1NO	30°	41°	6.5 N			
EP-x-5-20	Slow 3NC	30°	-	6.5 N			

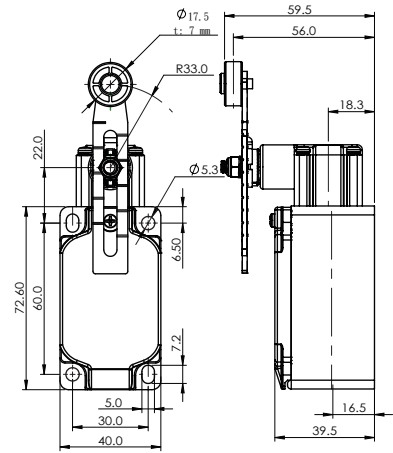

EP-31

Adjustable Roller Arm Type
(Long arm)



(Only for slow action models.)

Type	Contact Block	Operating travel (PT)	PT2nd	Operating Force (OF)	Positive Opening		Total Travel
					Travel (min)	Force (min)	
EP-x-1-21	Slow 1NC/1NO	30°	41°	5.2 N	45°	19.0 N	80°
EP-x-2-21	Slow 2NC	30°	-	5.2 N			
EP-x-3-21	Snap 1NC/1NO	28°	-	4.5 N			
EP-x-4-21	Slow 2NC/1NO	30°	41°	5.2 N			
EP-x-5-21	Slow 3NC	30°	-	5.2 N			

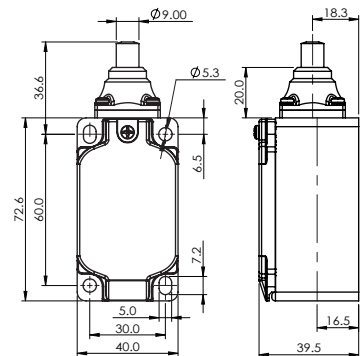

HIGHLY

A31

Design, specifications are subject to change without notice.

EP SERIES SAFETY LIMIT SWITCH

Operating Characteristics

Unit: mm

Item

Operating Characteristics

Dimensions

EP-32

Roller Plunger Type



Type	Contact Block	Operating travel (PT)	PT2nd	Operating Force (OF)	Positive Opening		Total Travel
					Travel (min)	Force (min)	
EP-x-1-32	Slow 1NC/1NO	2.2 mm	3.0	7.26 N	3.2 mm	19.0 N	6.0 mm
EP-x-2-32	Slow 2NC	2.2 mm	-	7.42 N			
EP-x-3-32	Snap 1NC/1NO	1.9 mm	-	6.71 N			
EP-x-4-32	Slow 2NC/1NO	2.2 mm	3.0	7.26 N			
EP-x-5-32	Slow 3NC	2.2 mm	-	7.42 N			

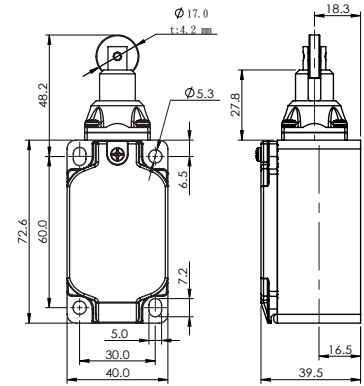

HIGHLY

A32

Design, specifications are subject to change without notice.