



# EDR SERIES SAFETY LIMIT SWITCHES WITH RESET

## Features

- Each model features a positive opening mechanism (NC contacts only) and equipped with a lockable head.
- Conforms to EN (TUV) standards corresponding to the CE marking.
- Positive opening operation of NC (Normally Closed) contacts conforming to IEC /EN 60947-5-1 
- Double insulation makes ground terminal unnecessary (Bears  marking)
- Wide standard operating temperature range: -25°C to 80°C
- Full range of actuator heads and levers suitable for safety applications
- Sealing up to IP 67
- Wide switch variations, (Snap action and slow action basic switches)
- International conduit sizes

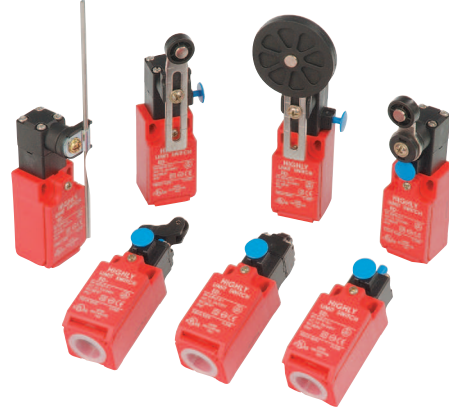

## Specifications

Standards	EN60947-5-1, UL508, EN50047, EN1088
Positive Opening Operation	NC Contact
Utilization Category	AC15 A600
Min Current	5V, 5mA, DC
Thermal Current (Ith)	10A
Rated Insulation Voltage	600 VAC
Rated Impulse withstand Volt	2500 VAC
Insulation Resistance	100M $\Omega$ min. (DC 500V)
Contact Resistance	25m $\Omega$ max. (Initial)
Max Switching Speed	250mm/s
Max Switching Frequency	6000 operation per hour
Enclosure Material	UL approved glass-filled polybutylene terephthalate
Enclosure Protection	IP 67
Operating Temperature	Min -25°C (-18°F) Max 80°C (+176°F)
Pollution Degree	3
Protection Against Electric Shock	Class II (Double Insulation)
Mech. Life Expectancy	1 x 10 <sup>6</sup> Cycle min
Electrically Life Expectancy	150,000 Cycle min
Vibration	IEC 68-2-6, 10-55Hz $\pm$ 1 Hz, Excursion: 0.35mm, 1 octave/min
Conduit Entry	Various (see Product Selection table)
Fixing	2 x M4

# EDR SERIES SAFETY LIMIT SWITCHES WITH RESET

## Structure description

### Metal Lever Setting

Grooves which engage the lever every 18° are cut in the operation indicator disk to prevent the lever from slipping against the rotary shaft.

### Contact Block

Has a positive opening mechanism separating the contacts when the contacts are welded.

### Cover

The cover, with a hinge on its lower part, can be opened by removing the screw of the cover, which ensures ease of maintenance and wiring.

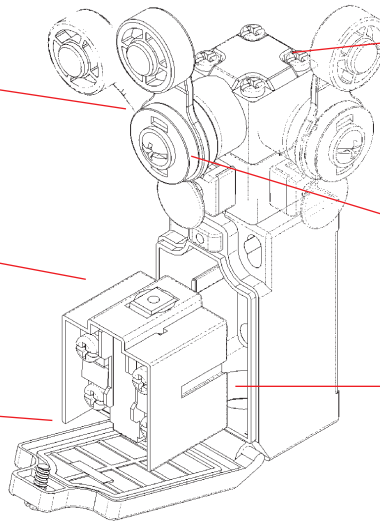

### Head

With roller lever models, the direction of the switch head can be adjusted to any of the four directions by loosening the roller lever switch screws at the four corners of the head.

### Reset Head

The direction of the reset head can be adjusted to any of the four directions.

### Conduit

Wide switch variations.  
PG13.5 PG11  
M16 M20  
1/2-14NPT

## Product Selection

EDR-□-□-□

1 2 3

### 1. THREAD DIMENSION OF LEAD EXIT

1: PG13.5	(s)
2: 1/2NPT	(c)
4: PG11	(o)
5: M16	(C)
6: M20	(O)
7: Connector	(C)

### 2. CONTACT TYPES

1:1NC/1NO SLOW ACTION (BBM)	(S)
2:2NC SLOW ACTION	(O)
3: 1NC/1NO SNAP ACTION(C)	
4: 2NC/1NO SLOW ACTION	
5: 3NC SLOW ACTION	

### 3. Key type

20: Roller arm type
21: Adjustable roller arm type (standard roller)
22: Adjustable roller arm type (Long arm type)
25: Rod lever type
27: Adjustable roller arm type (big roller)
31: Push plunger type
32: Roller plunger type
62: Roller lever type
63: One-Way roller arm lever type

\*(s):standard (o):option (c): customization

## Contact Block Form

TYPE	CONTACT FORM	CONNECTOR PIN ARRANGEMENT	OPERATION DIAGRAMS
EDR-□-1-□□	1NC/1NO(Slow action) (See Note 1)		
EDR-□-2-□□	2NC (Slow action) (See Note 2)		
EDR-□-3-□□	1NC/1NO(Snap action) (See Note 1)		
EDR-□-4-□□	3NC (Slow action)		<b>No Connector TYPE</b>
EDR-□-5-□□	2NC/1NO(Slow action)		

**HIGHLY**

A20

Design, specifications are subject to change without notice.







# EDR SERIES SAFETY LIMIT SWITCHES WITH RESET

## Operating Characteristics

Unit: mm

Item Operating Characteristics Dimensions

### ED-62

Roller Lever Type



Type	Contact Block	Operating travel (PT)	PT2nd	Operating Force (OF)	Positive Opening		Total Travel
					Travel (min)	Force (min)	
EDR-x-1-62	Slow 1NC/1NO	3.0 mm	4.5 mm	5.21 N	5.7 mm	19.0 N	5.2 mm
EDR-x-2-62	Slow 2NC	3.0 mm	-	5.26 N			
EDR-x-3-62	Snap 1NC/1NO	2.9 mm	-	4.74 N			
EDR-x-4-62	Slow 2NC/1NO	3.0 mm	4.5 mm	5.21 N			
EDR-x-5-62	Slow 3NC	3.0 mm	-	5.26 N			

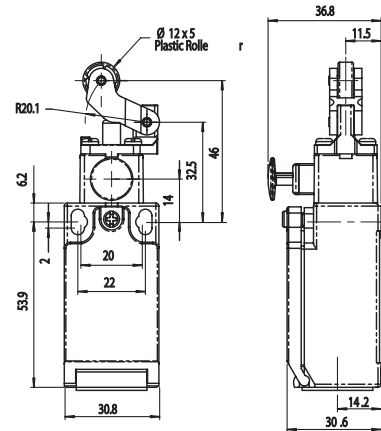

### EDR-63

One-Way Roller Arm Lever Type



Type	Contact Block	Operating travel (PT)	PT2nd	Operating Force (OF)	Positive Opening		Total Travel
					Travel (min)	Force (min)	
EDR-x-1-63	Slow 1NC/1NO	4.0 mm	6.0 mm	6.37 N	4.6 mm	19.0 N	9.8 mm
EDR-x-2-63	Slow 2NC	4.0 mm	-	6.98 N			
EDR-x-3-63	Snap 1NC/1NO	3.6 mm	-	5.76 N			
EDR-x-4-63	Slow 2NC/1NO	4.0 mm	6.0 mm	6.37 N			
EDR-x-5-63	Slow 3NC	4.0 mm	-	6.98 N			

