

ILLUMINATED

TACT SWITCHES

» Features

- Contact Reliability Clip type contacts are applied to ensure high reliability.
- For PC Board Terminals are all IC pitched (multiple of 2.54mm). By a particular terminal shape, the switch tightly when solder-dipped.
- Protection from Flux Entry Terminals are all completely sealed by epoxy.
- Many LED lights are available.

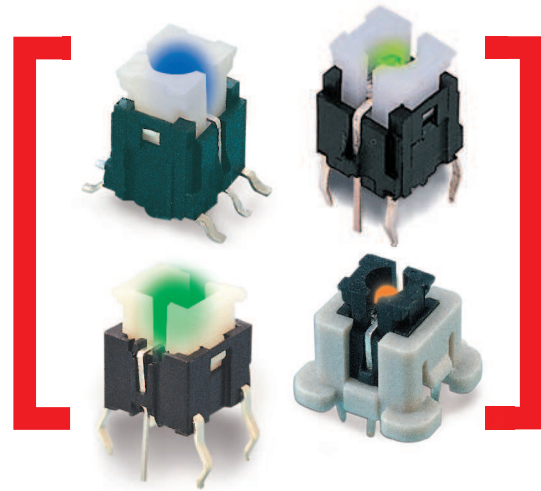

» Applications

- Operating switches in all types of electronic equipment such as audio apparatus, office equipment, communications apparatus, TV sets, VCRs, etc.

» Specifications

Rating	50mA 12VDC
Insulation Resistance	100MΩ Min (at 500 VDC)
Dielectric Resistance	AC 250V (50/60 Hz for 1 minute)
Contact Resistance	100mΩ Max. (Initial)
Electrically Life	300,000 Cycles Min
Ambient Temperature	-20°C ~ +70°C
Operating Force	160 ± 50gf
Travel	0.25 ± 0.1 mm

① FUNCTION

Non-illuminated	
-	Standard type
M	SMT type
X	Frame
Illuminated	
L	Standard type
ML	SMT type
X	Frame

② LED COLOR

1	Red
2	Yellow
3	Green
4	Blue
5	White
6	Pure Green
12	Red / Yellow
13	Red / Green
23	Yellow / Green

» Product selection

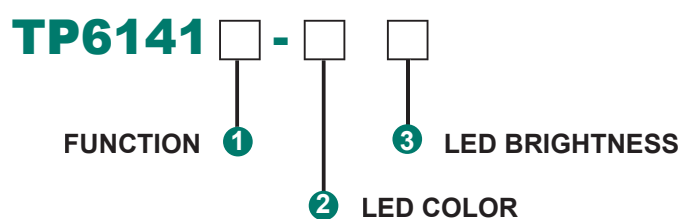

» LED Specifications

Color	VR	IF	Recommended Operating Current	VF	
				Nom	Max
Red	DC 5V	20mA	20mA	1.7V	2.4V
Green	DC 5V	20mA	20mA	1.9V	2.4V
Yellow	DC 5V	20mA	20mA	1.9V	2.4V
Blue	DC 5V	20mA	20mA	3.0V	3.6V
White	DC 5V	20mA	20mA	3.0V	3.6V

③ LED BRIGHTNESS

-	Standard
C	Customization

ILLUMINATED

TACT SWITCHES

» Operating characteristics

Unit: mm

Dimensions

Circuit P.C.B Layout

TP6141
TP6141L

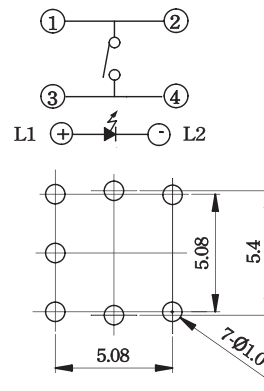
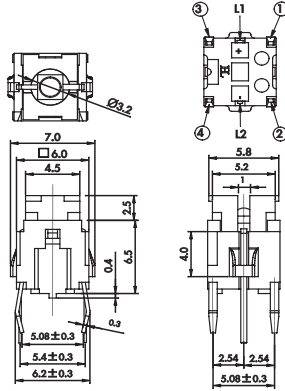

TP6141M
TP6141ML

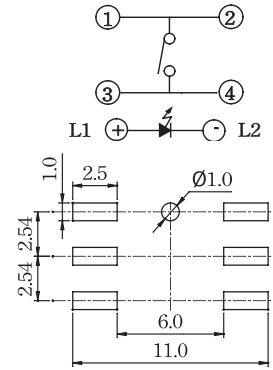
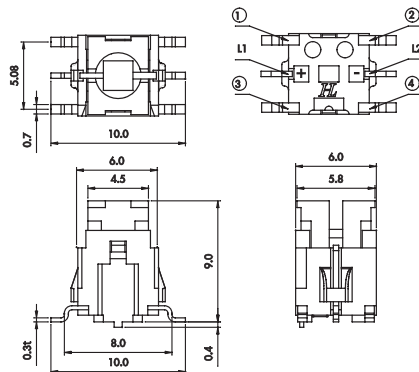
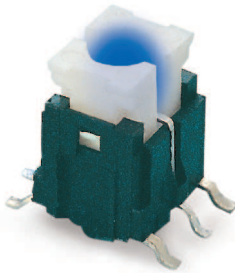

TP6143
TP6143L

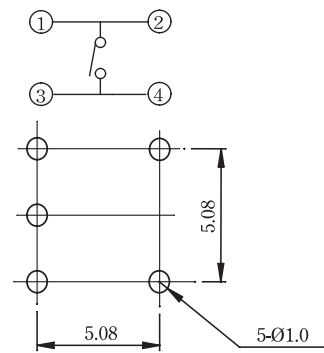
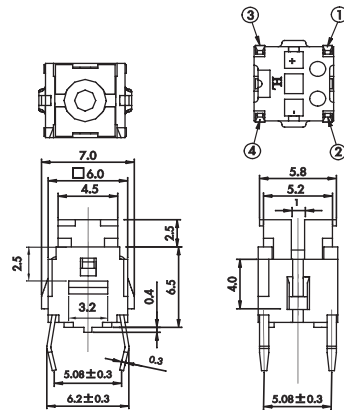
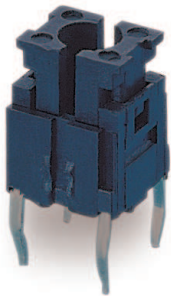

TP6143X
TP6143XL

