

» Features

- Contact Reliability Clip type contacts are applied to ensure high reliability.
- By a particular terminal shape, the switch tightly when solder-dipped.
- Protection from Flux Entry Terminals are all completely sealed by epoxy.
- Many LED lights are available.



» Applications

- Operating switches in all types of electronic equipment such as audio apparatus, office equipment, communications apparatus, TV sets, VCRs, etc.

» Specifications

Rating	50mA 12VDC
Insulation Resistance	100MΩ Min (at 500 VDC)
Dielectric Strength	AC 250V (50/60 Hz for 1 minute)
Contact Resistance	100mΩ Max. (Initial)
Electrically Life	300,000 Cycles Min
Ambient Temperature	-20°C~ +70°C
Operating Force	160 ± 50gf
Travel	0.25 ± 0.1 mm

» LED Specifications

Color	VR	IF	Recommended Operating Current	VF	
				Nom	Max
Red	DC 5V	20mA	20mA	1.7V	2.4V
Green	DC 5V	20mA	20mA	1.9V	2.4V
Yellow	DC 5V	20mA	20mA	1.9V	2.4V
Blue	DC 5V	20mA	20mA	3.0V	3.6V
White	DC 5V	20mA	20mA	3.0V	3.6V

For the specification about the other LEDs, please contact with sales department

» Product selection

TP 614

LED FUNCTION	
-	Non LED Standard type
L	LED Standard type

LED COLOR	
1	Red
2	Yellow
3	Green
4	Blue
5	White
6	Pure Green
8	Amber
9	Blue Green
10	Pink
011	Purple
12	Red/Yellow
13	Red/Green
14	Red/Blue
23	Yellow/Green
48	Blue/Amber
52	White/Yellow
58	White/Amber
-	Non-LED

LED BRIGHTNESS	
-	Standard
C	High Brightness

» Operating characteristics

Unit: mm

Dimensions

P.C.B Layout

TP614

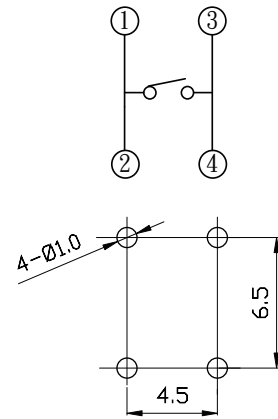
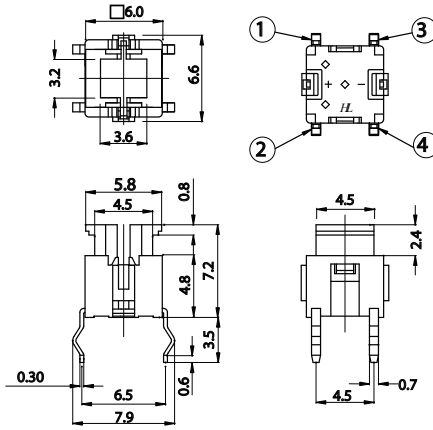
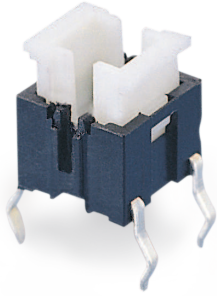

TP614L

