



Product Data Sheet

TS5620 Series

Vertical Diaphragm Valves

The TS5620 Series Vertical Diaphragm Valves are designed to dispense low to medium viscosity fluids with precision accuracy over a wide range of shot and bead sizes, down to a fraction of a micro liter. An internal spring return makes the valves fully adaptable for use with Techcon Systems controllers. A short opening stroke provides extremely fast, positive shut-off. An external stroke control adjustment makes it easy for the operator to fine tune shot sizes. The compact design allows for mounting flexibility and easy integration into automated applications.

The seal-less valve design features excellent moisture sensitive resistance and the incorporated diaphragm creates a barrier between the wetted parts and the air cylinder.

With a choice of UHMWPE (Ultra High Molecular Weight Polyethylene), Delrin® or Teflon® fluid bodies, the TS5620 Series Valve can handle a wide range of industrial fluids.

The valve is shipped with the following items:

- Mounting bracket kit
- Valve air hose
- Luer lock fluid line
- Fluid inlet fittings - 1/4" compression and Luer lock type
- Dispensing tip selection pack

TYPICAL APPLICATIONS

- Dispensing Anaerobic thread locker onto screw threads
- Dispensing Cyanoacrylate in bonding applications
- Applying a UV lacquer in CD/DVD spin coating applications (using Delrin® fluid housing)

KEY FEATURES AND BENEFITS

- Long cycle life
- Compact size and weight
- Excellent moisture sensitive resistance
- Choice of body for chemical compatibility

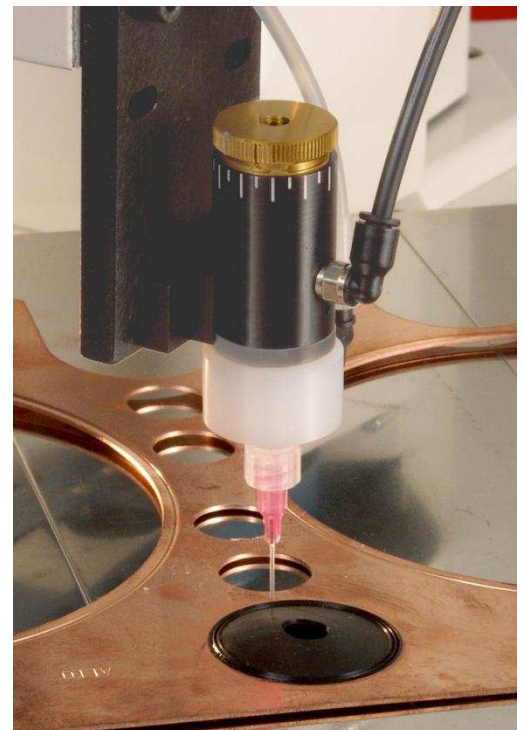

TYPICAL SETUP

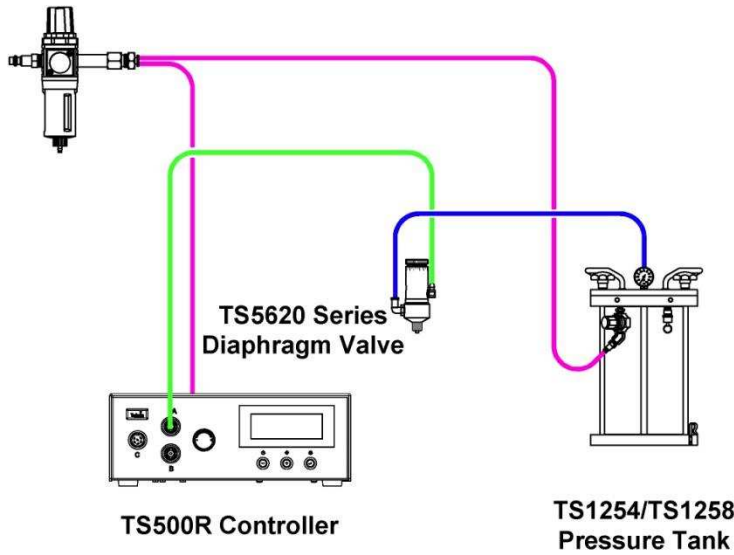

SPECIFICATIONS & PART NUMBERS

Part Number:	TS5620 Series
Size (Imperial):	See drawing
Size (Metric):	See drawing
Weight:	See below
Fluid Inlet Port:	1/8" NPT female
Fluid Outlet Port:	Luer lock male
Aux Air Inlet Port:	10-32 UNF female
Activation Pressure	70 psi - 90 psi
Range:	(4.8bar - 6.2bar)
Max Fluid Pressure:	70 psi (4.8bar)
Operating Frequency:	400+ cycles/min.
Mounting Port:	10-32 UNF female
Viscosity Range:	1 - 50 000cps

Wetted Parts	TS5622VU	0.14 lb (64g)	UHMWPE
And Weight	TS5622VT	0.18 lb (80g)	Teflon®
	TS5622VD	0.16 lb (71g)	UHMWPE, Delrin®
			(UHMWPE = Ultra High Molecular Weight Polyethylene)

ACCESSORIES

- **Fluid reservoirs:** The valve can be fed from the TS1254 or TS1258 Pressure Tank, or from any size syringe barrel or cartridge.
- **Dispensing Tips:** For the complete dispensing tip offering please visit www.techconsystems.com



LOCAL DISPENSING SOLUTIONS WORLDWIDE

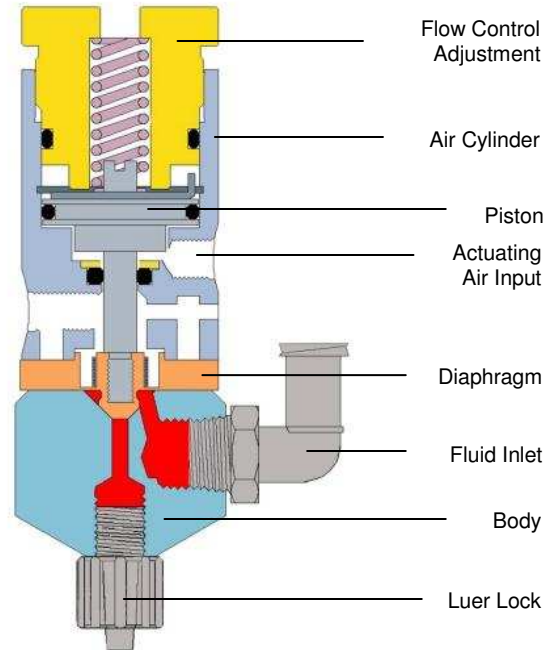

Dimensions are in inches [mm]

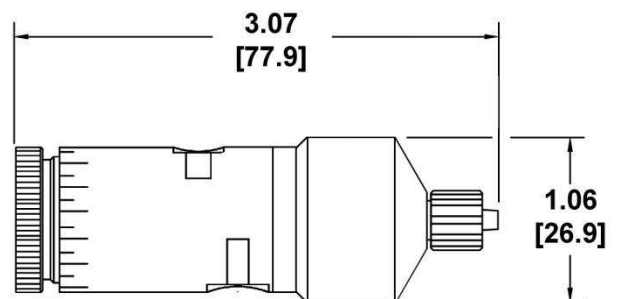

For Sales and Support:

Techcon Systems Corporate Headquarters,
12151 Monarch Street, Garden Grove,
California, 92841, USA.

Tel: 1-714-230-2398, Fax: 1-714-230-2393

E-mail: oemorders@okinternational.com

Techcon Systems European Corporate Office,
Eagle Close, Chandler's Ford Industrial Estate,
Eastleigh, Hampshire, SO53 4NF, UK.

Tel: +44 2380 489 100, Fax: +44 2380 489 109

E-mail: europa-orders@okinternational.com

Or visit www.techconsystems.com