



Product Data Sheet

TS1212 Pinch Tube Valve

The TS1212 Disposable Pinch Tube Valve provides control for dots and beads of low to medium viscosity fluids. The TS1212 relies on a dispensing controller sending a pre-programmed air signal that opens the valve and allows fluid to flow. Once the dispense cycle is complete, the air signal stops and the internal spring forces the shut-off piston to “pinch” the disposable feed path, preventing further fluid flow. A stroke control adjustment is built into the valve.

The only part of the valve making contact with the fluid, being dispensed, is the disposable pinch tube assembly making the TS1212 ideally suited for dispensing 2-part and CA (Cyanoacrylate) fluids.

The valve is shipped with the following items:

- Mounting rod
- Luer lock fluid lines (natural and black)
- Replacement “pinch” tubes
- Dispensing tip selection pack

TYPICAL APPLICATIONS

- Applying UV adhesive in medical device manufacturing
- Dispensing Cyanoacrylate (CA) to bond plastic parts in toy manufacturing
- Dispensing dots of lubrication in automotive switches

KEY FEATURES AND BENEFITS

- Disposable path – no cleaning required
- Very light-weight design
- Very low maintenance design
- Optional black feed paths for UV fluids



TYPICAL SETUP

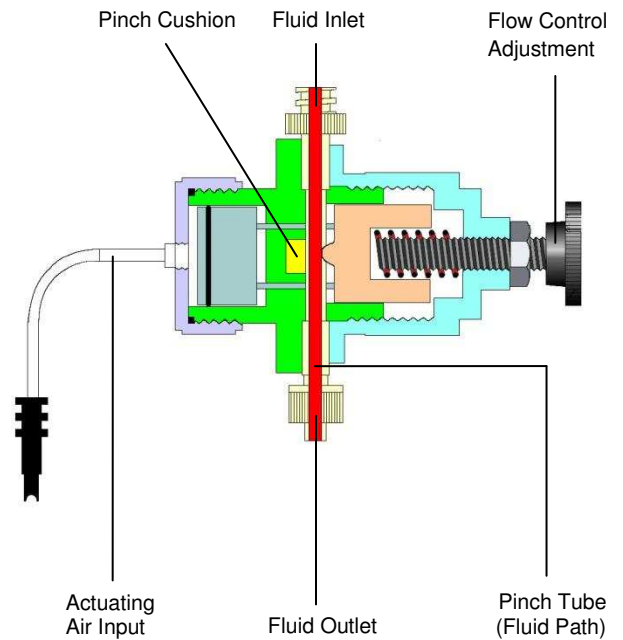
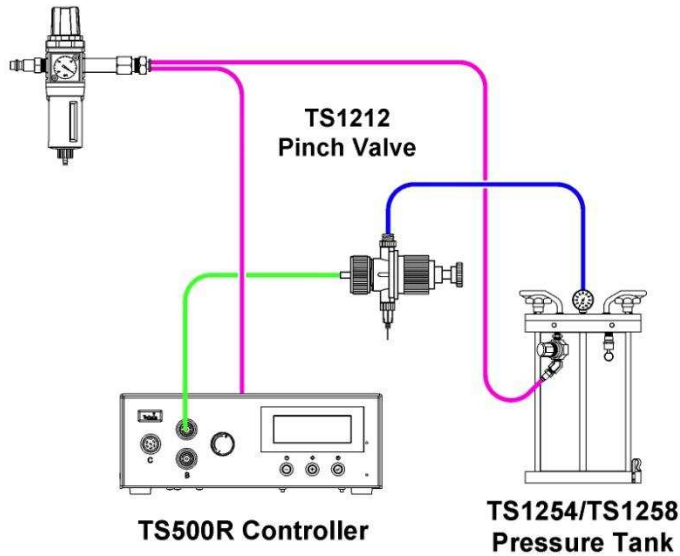

SPECIFICATIONS & PART NUMBERS

Part Number:	TS1212
Size (Imperial):	2.99" Length x 2.49"
Size (Metric):	76.0mm x 63.3mm
Weight:	0.18 lb (82g)
Fluid Inlet Port:	Luer lock female
Fluid Outlet Port:	Luer lock male
Activation Pressure:	50 psi (3.4bar) Min.
Max Fluid Pressure:	60 psi (4.1bar)
Operating Frequency:	400+ cycles/min.
Mounting Port:	¼-20 UNC-2B female
Viscosity Range:	1 - 45 000cps

Wetted Parts: Polyethylene, optional polyurethane

1212-004-002BPK	Black PE	0.1" (2.54mm) ID	Male to female	x10
1212-004-002PK	Natural PE	0.1" (2.54mm) ID	Male to female	x10
1212-004-000PK	Natural PE	0.07" (1.78mm) ID	Male to female	x10
1212-004-100BPK	Black PU	0.125" (3.18mm) ID	Male to female	x10
1212-004-100PK	Natural PU	0.125" (3.18mm) ID	Male to female	x10

ACCESSORIES

- Fluid reservoirs:** The valve can be fed from the TS1254 or TS1258 Pressure Tank, or from any size syringe barrel or cartridge.
- Dispensing Tips:** For the complete dispensing tip offering please visit www.techconsystems.com



LOCAL DISPENSING SOLUTIONS WORLDWIDE



Dimensions are in inches [mm]

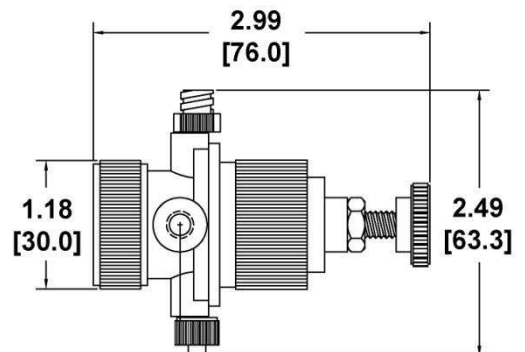

For Sales and Support:

Techcon Systems Corporate Headquarters,
12151 Monarch Street, Garden Grove,
California, 92841, USA.

Tel: 1-714-230-2398, Fax: 1-714-230-2393

E-mail: oemorders@okinternational.com

Techcon Systems European Corporate Office,
Eagle Close, Chandler's Ford Industrial Estate,
Eastleigh, Hampshire, SO53 4NF, UK.

Tel: +44 2380 489 100, Fax: +44 2380 489 109

E-mail: europa-orders@okinternational.com

Or visit www.techconsystems.com