

Product Data Sheet

TS5623 Series

Handheld Diaphragm Valves

TS5623 Series Hand Held Diaphragm Valves are designed to dispense low to medium viscosity material where a controlled timed shot is not required. The fluid housing and diaphragm are available in FDA-compliant Ultra High Molecular Weight Polyethylene (UHMWPE) for most applications. A Teflon® version for chemical compatibility and a Delrin® version for UV-curable are also available. The valves are easy to use and maintenance is simplified with user replaceable spare parts.

The seal-less valve design features excellent moisture sensitive resistance and the incorporated diaphragm creates a barrier between the wetted parts and the rear cylinder.

The hand held valve does not require a controller for activation, as the valve is actuated by the use of a mechanical hand lever. These valves are designed for the operator to manually dispense low to medium viscosity fluids, such as Cyanoacrylates, Anaerobics and solvents.

The valve is shipped with the following items:

- Luer lock fluid line
- Dispensing tip selection pack

TYPICAL APPLICATIONS

- Dispensing Anaerobic thread locker onto screw threads
- Dispensing Cyanoacrylate in bonding applications
- Applying adhesive for speaker bonding

KEY FEATURES AND BENEFITS

- Long cycle life
- Compact size and weight
- Excellent moisture sensitive resistance
- Choice of body for chemical compatibility
- Convenient hanger



TYPICAL SETUP

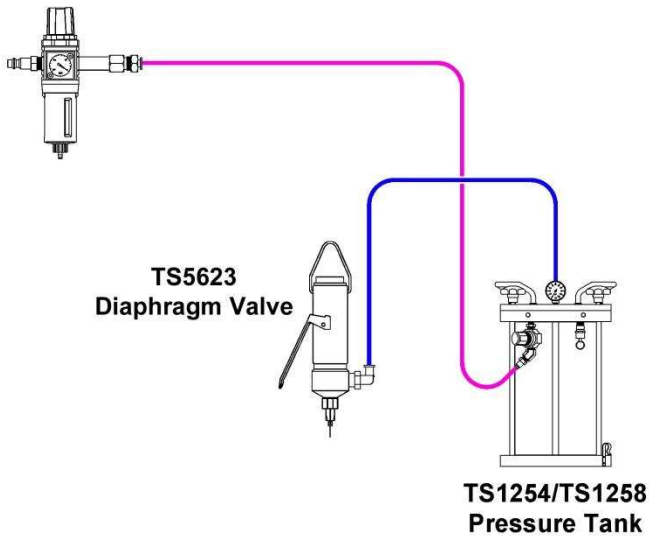

■ FLUID
■ CONSTANT AIR

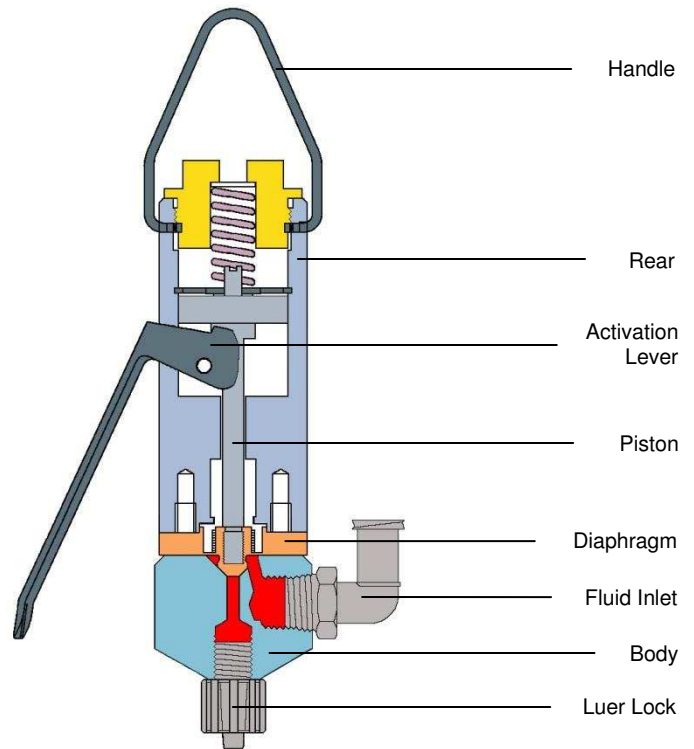

SPECIFICATIONS & PART NUMBERS

Part Number:	TS5623 Series
Size (Imperial):	3.9" Length x 1.06"
Size (Metric):	99.1mm x 26.9mm
Weight:	See below
Fluid Inlet Port:	1/8" NPT female
Fluid Outlet Port:	Luer lock male
Max Fluid Pressure:	70 psi (4.8bar)
Viscosity Range:	1 - 50 000cps

Wetted Parts	TS5623HU	0.227 lb (103g)	UHMWPE
And Weight	TS5623HT	0.257 lb (117g)	Teflon®
	TS5623HD	0.245 lb (111g)	UHMWPE, Delrin® (UHMWPE = Ultra High Molecular Weight Polyethylene)

Dimensions are in inches [mm]

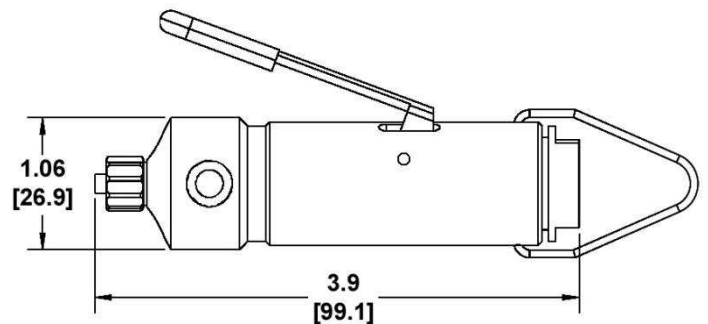

ACCESSORIES

- Fluid reservoirs:** The valve can be fed from the TS1254 or TS1258 Pressure Tank, or from any size syringe barrel or cartridge.
- Dispensing Tips:** Specially designed "TF" Teflon® lined tips are recommended when dispensing Cyanoacrylate (CA). The lining prevents premature cure. For the complete dispensing tip offering please visit www.techconsystems.com.

For Sales and Support:

Techcon Systems Corporate Headquarters,
 12151 Monarch Street, Garden Grove,
 California, 92841, USA.

Tel: 1-714-230-2398, Fax: 1-714-230-2393

E-mail: oemorders@okinternational.com

Techcon Systems European Corporate Office,
 Eagle Close, Chandler's Ford Industrial Estate,
 Eastleigh, Hampshire, SO53 4NF, UK.

Tel: +44 2380 489 100, Fax: +44 2380 489 109

E-mail: europa-orders@okinternational.com

Or visit www.techconsystems.com



LOCAL DISPENSING SOLUTIONS WORLDWIDE

Teflon® is a registered trademark of E.I. DuPont. Version 2.00