



Product Data Sheet

TS9000 Series

Jet Tech

The TS9000 Series Jet Tech is a piezoelectric driven, non contact dispense valve capable of handling fluid viscosities to 2 million Cps. Jet Tech offers a fast jetting action producing hundreds of accurate deposits less than one second.

Every component of the valve was designed to the highest tolerances and manufactured to the strictest degree of precision insuring world class accuracy and repeatability in drop-to-drop dispensing volume.

Jet Tech's compact size and modular design aids integration into robotic systems. The valve features fully adjustable parameter settings, allowing the operator to change the jetting properties for different fluid types and optimize the process for repeatable dispensing.

A variety of nozzles shape and sizes along with different tappet configurations provides a wide spectrum of output jet deposits.

The Jet Tech system is shipped with the following items:

- Valve
- Controller
- Cables (sensor, actuator and power cable)
- Nozzle tools

TYPICAL APPLICATIONS

The TS9000 Jet Tech can be used in wide range of applications. Some examples of processes and applications are:

- Jetting silver epoxies for die bonding processes
- Jetting silicone phosphor in the LED assembly process
- Jetting under-fill in micro-electronic package applications on PCBA
- Jetting micro dots of UV adhesive in medical device applications

FEATURES AND BENEFITS

- Non contact Jetting technology
- Accurate and precise dispensing
- Extremely high speed, up to 1000 Hz
- Repeatable drop size as small as 2 nl
- Jet fluid from 7K to 2 million Cps
- Small modular design
- Easy and fast cleaning
- Field replaceable spare parts
- Low total cost of ownership



TYPICAL SETUP

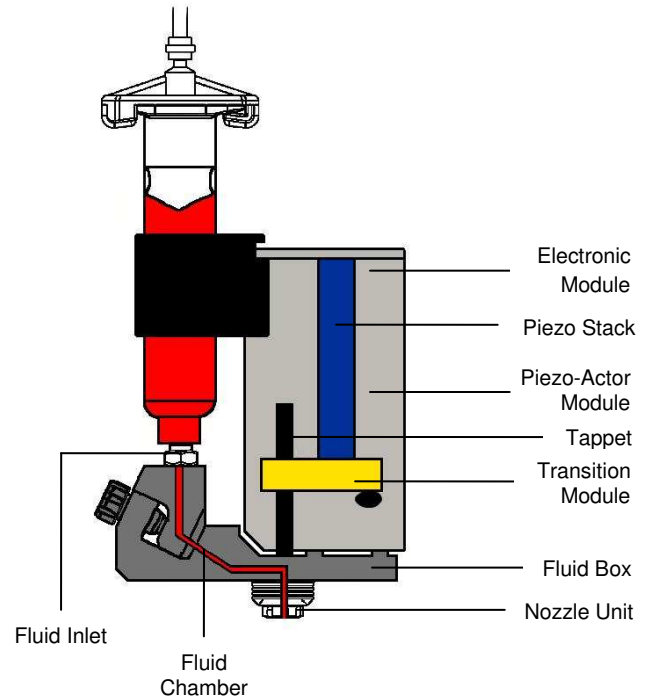
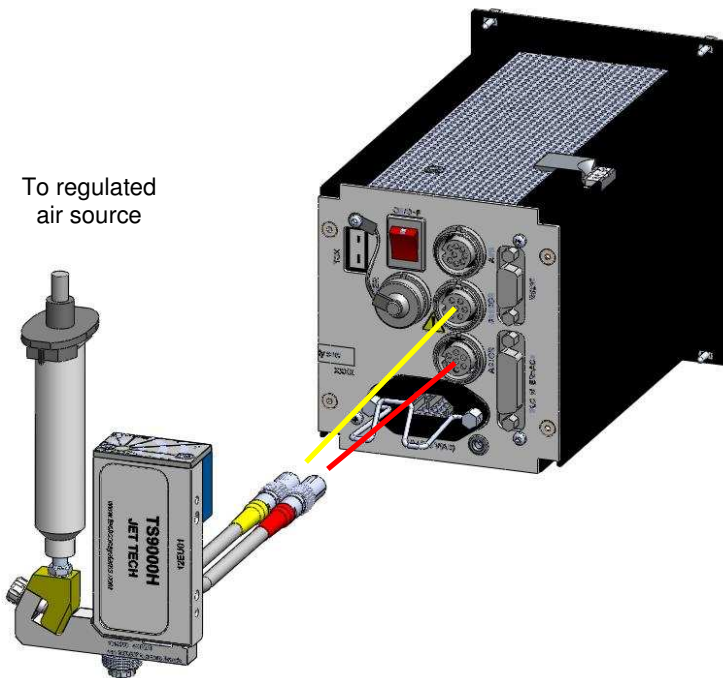

JET VALVE SYSTEM SPECIFICATIONS

Size Valve (Imperial):	3.54" x 2.98" x 0.86"
Size Valve (Metric):	90.0mm x 75.7mm x 22.0mm
Size Controller (Imperial):	4" x 11.61" x 5.06"
Size Controller (Metric):	101.6mm x 295mm x 128.4mm
Weight Valve:	258g
Weight Controller:	1600g
Minimum Shot Size:	2nl
Viscosity Range:	7K to 2000K Cps.
Fluid Pressure Range:	1 to 116 psi (0.1 to 8.0bar)
Nozzle Orifice Diameter Range:	0.07 mm to 0.40mm
Max. Dispensing Frequency:	1000 Hz
Power Connection:	10 sets internally; unlimited ext.
Standard Interface:	RS232; 24V/5V PLC
Operating Temperature:	10 to 50 °C

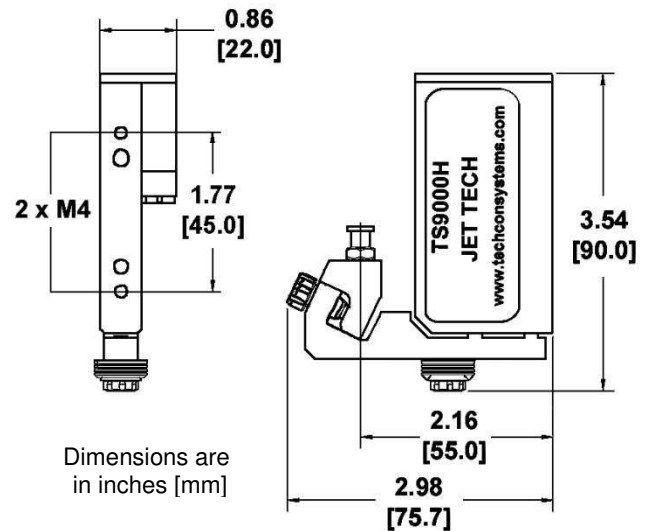

ACCESSORIES

- **Nozzle and tappets:** A range of nozzles/tappets are made available to accommodate a variety of output jet deposits.
- **Heater module:** The valve's fluid box can be heated to reduce the viscosity of thicker fluids allowing an increase in flow rates.
- For the complete nozzle/tappet and heater offering please visit www.techconsystems.com

For Sales and Support:

Techcon Systems European Corporate Office,
Eagle Close, Chandler's Ford Industrial Estate,
Eastleigh, Hampshire, SO53 4NF, UK.
Tel: +44 2380 489 100, Fax: +44 2380 489 109
E-mail: europa-orders@okinternational.com

Or visit www.techconsystems.com



LOCAL DISPENSING
SOLUTIONS WORLDWIDE

PART NUMBER ORDERING

For the complete Jet Tech Valve System 4 part numbers are required for ordering purposes – *Jet Tech valve/controller, supply unit option, tappet option and the nozzle insert option*. TS9000SYS-H is the part number for the main system. This part number consists of:

- Jet Tech Valve (Electrical section) and Jet Controller

The Supply Unit is the fluid housing assembly that includes the fluid housing, tappet seal, tappet bearing, washer, fluid inlet fitting and syringe bracket.

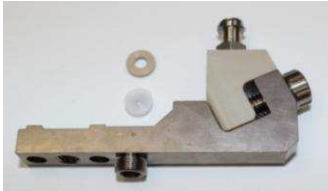

SELECT ONE:

PART NUMBER	DESCRIPTION
7504-0170-1	Supply Unit Assembly for 10cc
7504-0170-2	Supply Unit Assembly for 30/55cc
7504-0170-3	Supply Unit Assembly for 5cc
7504-0170-4	Supply Unit Assembly for 3cc

The connection between the tappet and the piezo is established by means of a lever. This lever transmits the distention and contraction of the piezo of the tappet, which in consequence continuously moves up and down and pushes the fluid to be dispensed through the orifice of the nozzle. Since the tappet is considered as a wearing part, regular maintenance of the tappet is mandatory. If the tappet is not cleaned or greased at regular intervals, the accuracy of the dispense process will decrease. The table below shows available sizes of the tappet for the TS9000H Jet Tech valve.



SELECT ONE:

PART NUMBER	DESCRIPTION
7504-0150-1	Tappet TTF4 Tungsten Carbide 0.4mm
7504-0150-2	Tappet TTF5 Tungsten Carbide 0.5mm
7504-0150-3	Tappet TTF6 Tungsten Carbide 0.6mm
7504-0150-4	Tappet TTF7 Tungsten Carbide 0.7mm
7504-0150-5	Tappet TTF10 Tungsten Carbide 1.0mm
7504-0150-6	Tappet TTF15 Tungsten Carbide 1.5mm

The nozzle insert determines the drop size. The smaller the nozzle insert orifice – the smaller the drop size. Consult Techcon Systems to select the right nozzle insert.

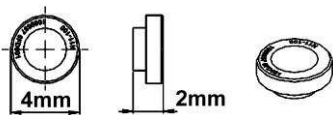

SELECT ONE:

PART NUMBER	DESCRIPTION
7504-0160-1	Nozzle Insert N11-70, 0.07mmØ
7504-0160-2	Nozzle Insert N11-100, 0.10mmØ
7504-0160-3	Nozzle Insert N11-120, 0.12mmØ
7504-0160-4	Nozzle Insert N11-150, 0.15mmØ
7504-0160-5	Nozzle Insert N11-200, 0.20mmØ
7504-0160-6	Nozzle Insert N14-300, 0.30mmØ
7504-0160-7	Nozzle Insert N14-400, 0.40mmØ