

Product Data Sheet

TS9200D Series

Jet Tech

The TS9200D Jet Tech is a non-contact dispense valve capable of jetting fluid viscosities to 400,000 Cps. Jet Tech offers a fast jetting action producing hundreds of precise droplets in less than one second.

The main feature of the valve is a single, easily replaceable diaphragm to eliminate dynamic fluid seals found in other jet valves. No longer is it necessary to disassemble, clean and replace worn seals, which translates into saving time and money. The diaphragm also allows fast cycle rates because of its very small mass. There is no large sliding valve stem that slows down the process. With this novel diaphragm design, the energy needed to eject a drop can be adjusted providing a wider process window.

It's Fast – 300 drops/sec continuous duty. 50% increase in throughput over conventional Jet valves.

It's Simple to Clean – only 2 parts contact the fluid. Conventional Jet valves can have as many as 8 parts requiring cleaning. With only two parts to clean, cleaning the TS9200D takes only minutes and there is no need to remove the Jet valve from the robot. A diaphragm and nozzle plate can be installed immediately without the need to carefully calibrate the Jet valve saving valuable production time and no special off-line cleaner is required.

It's Capable – the TS9200D generates a very high drop velocity allowing a wide range of fluids and applications. In addition, the drop velocity can be easily changed to help fine tune the process and achieve a high process capability and wide process window.

It's Cool – the advanced electronic drive provides power when required and reduces power when idle. The internal air flow cools the Jet body so it runs cool even during high-speed, continuous operation. The integral nozzle heater heats only the fluid in the nozzle plate and is thermally isolated from the jet body.

It's Easy to Integrate – In combination with the standalone TS920 controller, a single trigger line is all that is needed to be dispensing complex dispensing programs.

FEATURES AND BENEFITS

- Non contact Jetting technology
- Accurate and precise dispensing
- High speed, up to 300 drops/sec
- Repeatable drop size as small as 10 nl
- Jet fluid up to 400K Cps.
- No fluid seals to clean or replace
- Integral heater with minimal fluid heated
- Quick and simple setup
- Low total cost of ownership

JET VALVE SYSTEM SPECIFICATIONS

Size Width:	50.8mm (2.00")
Size Depth:	93.8mm (3.69")
Size Height:	88.9mm (3.50")
Weight :	348g (0.77lb)
Speed:	Up to 300Hz Continuous Duty
Syringe Capacity:	5, 10, 30 and 55cc
Minimum Shot Size:	10nl
Viscosity Range:	1 to 400K Cps.
Fluid Pressure:	40 psi (2.76bar)
Nozzle Sizes:	100µm, 125µm, 150µm, 200µm,
Jet Pressure:	35psi to 70psi (2.41 to 4.8bar)
Controller Interface:	RS-232 & LCD Display w/Interface
Input/Output:	TTL Level Triggers
Operating Temperature:	10 to 50°C

Dimensions are in inches [mm]

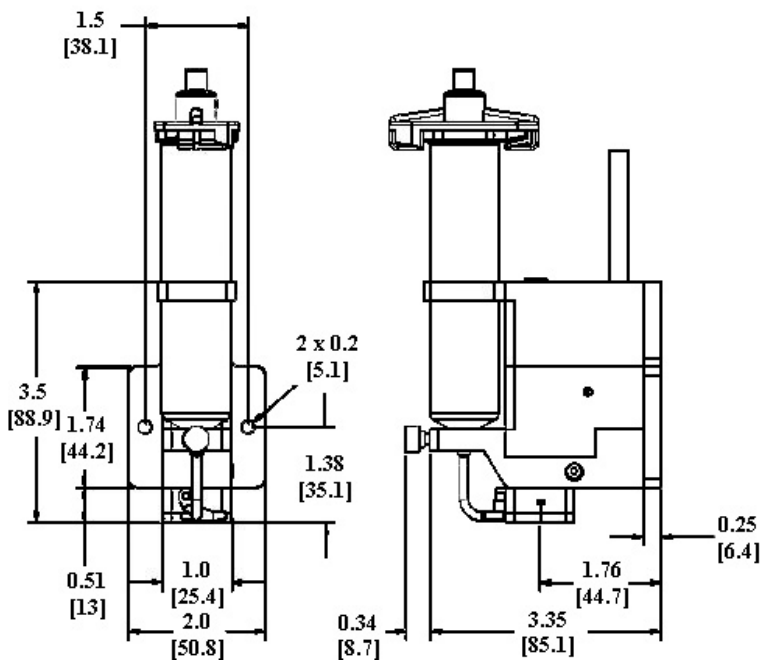

PART NUMBER ORDERING

TS9200D-125E	Jet Valve EPDM Diaphragm, 125µm Nozzle
TS9200D-150E	Jet Valve EPDM Diaphragm, 150µm Nozzle
TS9200D-200E	Jet Valve EPDM Diaphragm, 200µm Nozzle
TS9200D-125S	Jet Valve Silicone Diaphragm, 125µm Nozzle
TS9200D-150S	Jet Valve Silicone Diaphragm, 150µm Nozzle
TS9200D-200S	Jet Valve Silicone Diaphragm, 200µm Nozzle



**LOCAL DISPENSING
SOLUTIONS WORLDWIDE**

TYPICAL APPLICATIONS

The TS9000 Jet Tech can be used in wide range of applications. Some examples of processes and applications are:

- Jetting silver epoxies for die bonding processes
- Jetting silicone phosphor in the LED assembly process
- Jetting under-fill in micro-electronic package applications on PCBA
- Jetting micro dots of UV adhesive in medical device applications

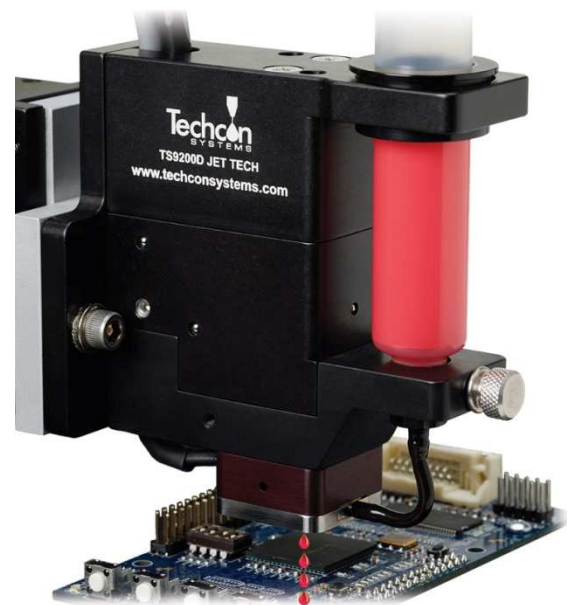

For Sales and Support:

Techcon Systems Corporate Headquarters,
12151 Monarch Street, Garden Grove,
California, 92841, USA.

Tel: 1-714-230-2398, Fax: 1-714-230-2393

E-mail: [OEMorders@okinternational.com](mailto: OEMorders@okinternational.com)

Or visit www.techconsystems.com

