

VIKING PRODUCT MANUAL

COMMUNICATION & SECURITY SOLUTIONS

LED Strobe and/or Beacon Visual Indicator with Programmable Brightness and Flash Patterns

The **SL-2** is a 360° LED Strobe and/or Beacon visual indicator. LED's not only are more efficient and last longer than standard flash tubes but are also immune to shock and vibration. The LED's are internally positioned to allow a 360° viewing angle when the unit is mounted vertically and a 120° viewing angle when side mounted.

The **SL-2** can be user programmed to output 4 different flash patterns: Single Flash, Double Flash, Quad Flash or Flicker Flash. The unit can also be programmed as a continuous-On Beacon only, Strobe only or Beacon/Strobe allowing a lower intensity beacon to remain on and a high intensity strobe to be activated by a contact closure. 6 different brightness levels are also programmable for the Beacon and the Strobe. All programming is stored in non-volatile memory so you won't lose the programming when the unit is powered down, allowing you to program units prior to installation.

The **SL-2** is designed for indoor applications and comes standard with a Blue shatter resistant polycarbonate lens. Optional Red, Amber and Clear lenses are sold separately (go to www.vikingelectronics.com and click on spare parts). Unit surface

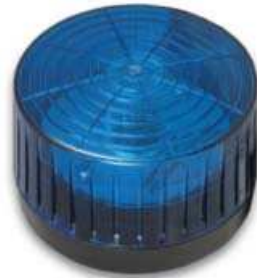

mounts to wall, post, panel, 4" electrical box or wet location electrical box round lamp holder cover.

The model **SL-2-EWP** adds Enhanced Weather Protection (EWP) for outdoor installations where the unit is exposed to precipitation or condensation. EWP products feature foam rubber gaskets and boots, sealed connections, gel-filled butt connectors, as well as urethane or thermal plastic potted circuit boards with internally sealed, field-adjustable trim pots and DIP switches for easy on-site programming. For more information, see **DOD# 859**.

Features

- High output long life LED technology
- Four programmable flash patterns:
 - Single Flash
 - Double Flash
 - Quad flash
 - Flicker Flash
- 6 programmable beacon and strobe brightness settings
- Immune to shock and vibration
- Low current draw
- Shatter resistant polycarbonate lens
- **SL-2-EWP** is designed to meet IP66 ingress Protection Rating (see **DOD# 859**)

Applications

- High noise level areas where visual status is required
- Signal personnel of equipment malfunctions
- Warn personnel they are entering a restricted area

Specifications

Power: 10- 15VDC 0.90 Amp (Peak), 0.15 Amp (Avg) @ 15VDC. **Note:** Power supply not included. The **SL-2** is compatible with Viking model **PS-2** 12VDC power supply.

Maximum Wire Run Length with CAT-5 and PS-2 Power Supply: 3 wires = 100 ft, 6 wires = 300 ft
Dimensions: 112mm diameter x 70mm (4.41" diameter x 2.76")

Shipping Weight: 0.25 kg (0.6 lbs)

Environmental: -40°C to 60°C (-40°F to 140°F)

Strobe Flash Rate: 60 flashes per minute (default) see Strobe Flash Patterns page 4

Maximum Strobe Light Output @ 15VDC: Clear lens: 323 lumens, Amber lens: 242 lumens, Blue lens: 116 lumens, Red lens: 66 lumens

Humidity - SL-2: 5% to 95% non-condensing

Humidity - SL-2-EWP: up to 100% condensing

Connections: Three 9" (22.9 cm) long leads, 26 AWG

www.vikingelectronics.com

Information: (715) 386-8861

Installation

A. Mounting the SL-2

FRONT MOUNTING TO ELECTRICAL BOX

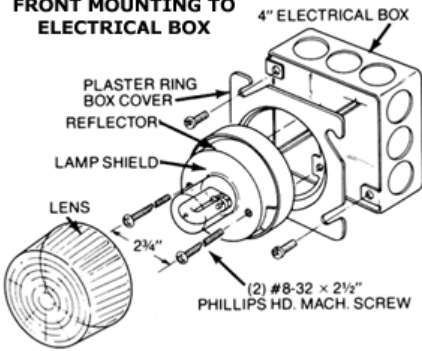

FRONT MOUNTING TO WALL OR PANEL

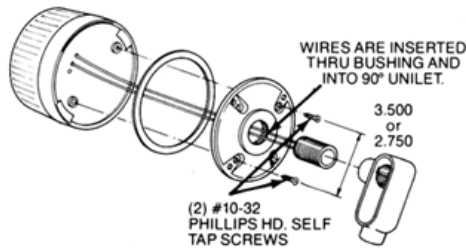
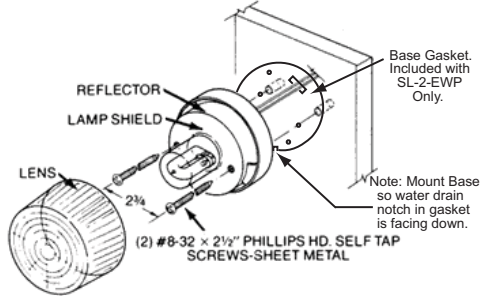

REAR MOUNTING TO ADAPTER PLATE

DRILL TEMPLATE

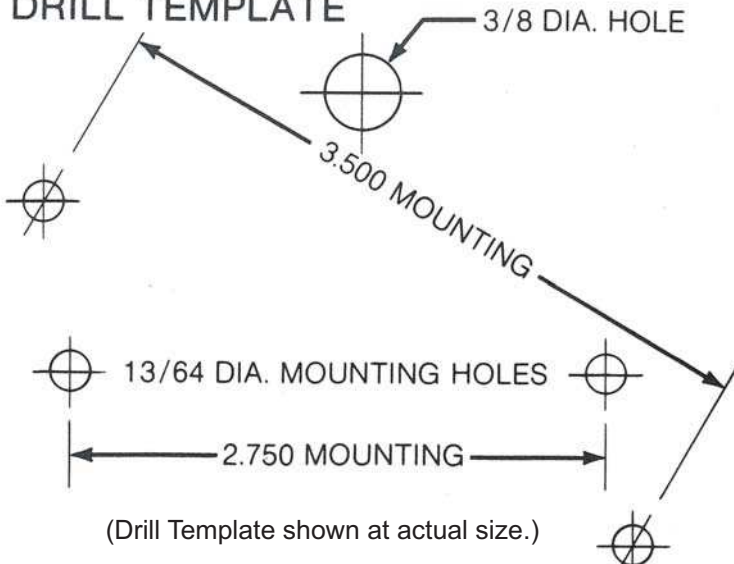

B. Wiring the SL-2

Strobe Only (Low Current Contacts)

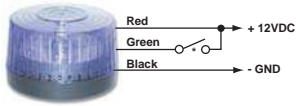

In programming, select programming feature 2 (strobe only). When the switch/contact is activated, the strobe will flash for the duration of the contact closure.

* **Note:** Switch / dry contact closure with a minimum contact rating of 25mA @ 15VDC.

Strobe Only (High Current Contacts)

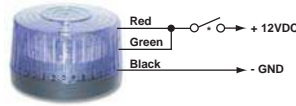

In programming, select programming feature 1 (beacon/strobe, factory default). When the switch/contact is activated, the strobe will flash for the duration of the contact closure.

* **Note:** Switch / dry contact closure with a minimum contact rating of 900mA @ 15VDC.

Beacon Only

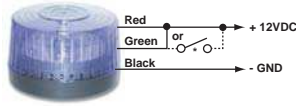

In programming, select programming feature 3 (beacon only). With the green wire connected to the red wire, when power is applied the steady on beacon will

turn on. An optional low current switch or contact can be used between the green and red wire to turn the beacon on or off.

Beacon / Strobe

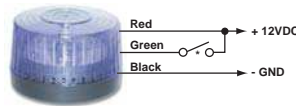

In programming, select programming feature 1 (beacon/strobe, factory default). When power is applied the lower intensity steady-on beacon will light. When the switch/contact is activated, the beacon will turn off and the strobe will flash for the duration of the contact closure.

the switch/contact is activated, the beacon will turn off and the strobe will flash for the duration of the contact closure.

Programming

The **SL-2** can be user programmed as a Beacon only, Strobe only or Beacon/Strobe. The brightness setting can be programmed separately for the Strobe or Beacon and one of 4 different Flash Patterns can be programmed for the Strobe (See Strobe Flash Patterns, section D).

A. Accessing the Programming Mode

(Optional, the **SL-2** is factory programmed to the Beacon/Strobe Mode and brightest Beacon/Strobe settings).

Step 1.	Apply 10-15 VDC power to the Red (+) and Black (-) wires.
Step 2.	Touch and hold the Green (Control) wire to the Black (-) wire for 3 seconds. The strobe should flash twice. You are now in Programming mode. Note: <i>Once in the programming mode, if a programming command has not been entered for 20 seconds the strobe will flash 3 times indicating the unit has exited programming and returned to the Run Mode.</i>

B. Programming Desired Features (after accessing Programming Mode above)

Select the Feature: Momentarily touch the Green (Control) wire to the Black (-) wire 1 to 10 times to select which feature to program (see Programming Features List, section C). The strobe should momentarily flash each time the Green (Control) wire has touched the Black (-) wire.

Features 1-3 & 6-10: After selecting Programming Features 1-3 or 6-10, wait 3 seconds and the strobe should flash 2 times indicating that feature has been programmed. You can now exit programming or move on to programming the Beacon or Strobe brightness settings.

Setting Strobe Brightness (factory set to 6/Brightest): After selecting Programming Feature 4 (Strobe Brightness), wait 3 seconds and the strobe should begin flashing in the preprogrammed flash pattern. Touch and hold the Green (Control) wire to the Black (-) wire. The **SL-2** will begin flashing the strobe cycling through 6 different brightness settings from lowest to highest. When the **SL-2** flashes at the desired brightness level immediately remove the Green wire from the Black. The **SL-2** should flash twice indicating the selected brightness level has been set.

Setting Beacon Brightness (Factory set to 6/Brightest): After selecting Programming Feature 5 (Beacon Brightness), wait 3 seconds and the beacon will light at its preprogrammed beacon brightness setting. Touch and hold the Green (Control) wire to the Black (-) wire. The **SL-2** will begin stepping through 6 different beacon brightness settings from lowest to highest. When the **SL-2** lights at the desired beacon brightness level immediately remove the Green wire from the Black. The **SL-2** should flash twice indicating the selected brightness level has been set.

Exiting Programming: To exit programming simply wait 20 seconds from the last programming command and the unit will flash 3 times. This indicates the **SL-2** has exited the programming mode and is now in the Run mode. **Note:** *To eliminate waiting 20 seconds, you can also exit programming after the last programming command by touching and holding the Green (Control) wire to the Black (-) for 3 seconds. The strobe will flash 3 times indicating the unit has exited the programming mode and is now in the Run mode.*

C. Programming Features List

Feature #:	Description:
1	Beacon/Strobe (factory default)
2	Strobe Only
3	Beacon Only
4	Strobe Brightness 1-6 (factory default = 6, brightest setting)
5	Beacon Brightness 1-6 (factory default = 6, brightest setting)

Feature #:	Description:
6	Single Flash Strobe (factory default)
7	Double Flash Strobe
8	Quad Flash Strobe
9	Flicker Flash Strobe
10	Reset to Factory Default Settings

D. Strobe Flash Patterns

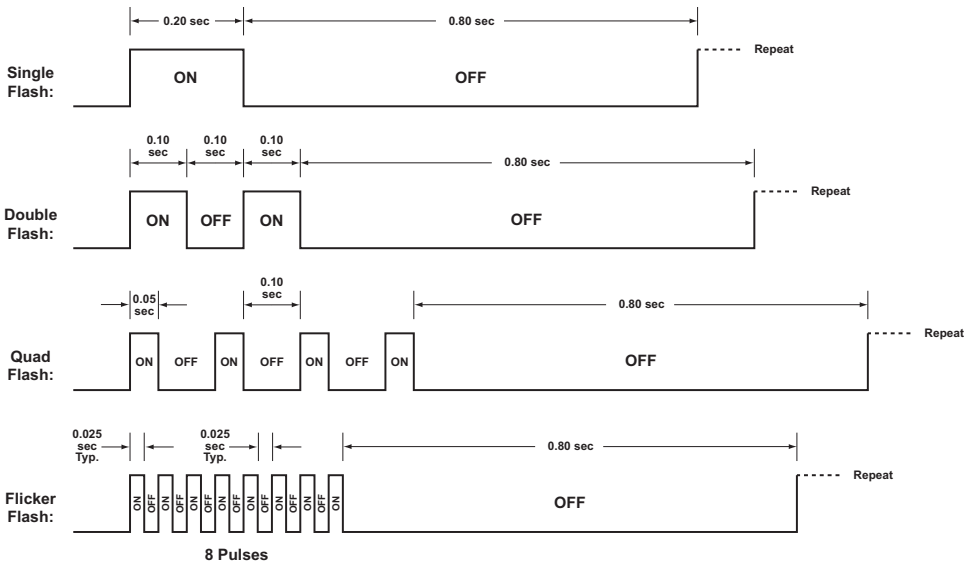

Warranty

IF YOU HAVE A PROBLEM WITH A VIKING PRODUCT, CONTACT: VIKING TECHNICAL SUPPORT AT (715) 386-8666

Our Technical Support Department is available for assistance Monday 8am - 4pm and Tuesday through Friday 8am - 5pm central time. So that we can give you better service, before you call please:

1. Know the model number, the serial number and what software version you have (see serial label).
2. Have your Technical Practice in front of you.
3. It is best if you are on site.

RETURNING PRODUCT FOR REPAIR

The following procedure is for equipment that needs repair:

1. Customer must contact Viking's Technical Support Department at 715-386-8666 to obtain a Return Authorization (RA) number. The customer MUST have a complete description of the problem, with all pertinent information regarding the defect, such as options set, conditions, symptoms, methods to duplicate problem, frequency of failure, etc.
2. Packing: Return equipment in original box or in proper packing so that damage will not occur while in transit. Static sensitive equipment such as a circuit board should be in an anti-static bag, sandwiched between foam and individually boxed. All equipment should be wrapped to avoid packing material lodging in or sticking to the equipment. Include ALL parts of the equipment. C.O.D. or freight collect shipments cannot be accepted. Ship cartons prepaid to: **Viking Electronics, 1531 Industrial Street, Hudson, WI 54016**
3. Return shipping address: Be sure to include your return shipping address inside the box. We cannot ship to a PO Box.
4. RA number on carton: In large printing, write the R.A. number on the outside of each carton being returned.

RETURNING PRODUCT FOR EXCHANGE

The following procedure is for equipment that has failed out-of-box (within 10 days of purchase):

1. Customer must contact Viking's Technical Support at 715-386-8666 to determine possible causes for the problem. The customer MUST be able to step through recommended tests for diagnosis.
2. If the Technical Support Product Specialist determines that the equipment is defective based on the customer's input and troubleshooting, a Return Authorization (R.A.) number will be issued. This number is valid for fourteen (14) calendar days from the date of issue.
3. After obtaining the R.A. number, return the approved equipment to your distributor, referencing the R.A. number. Your distributor will then replace the Viking product using the same R.A. number.
4. **The distributor will NOT exchange this product without first obtaining the R.A. number from you. If you haven't followed the steps listed in 1, 2 and 3, be aware that you will have to pay a restocking charge.**

TWO YEAR LIMITED WARRANTY

Viking warrants its products to be free from defects in the workmanship or materials, under normal use and service, for a period of two years from the date of purchase from any authorized Viking distributor. If at any time during the warranty period, the product is deemed defective or malfunctions, return the product to Viking Electronics, Inc., 1531 Industrial Street, Hudson, WI., 54016. Customer must contact Viking's Technical Support Department at 715-386-8666 to obtain a Return Authorization (R.A.) number.

This warranty does not cover any damage to the product due to lightning, over voltage, under voltage, accident, misuse, abuse, negligence or any damage caused by use of the product by the purchaser or others. This warranty does not cover non-EWP products that have been exposed to wet or corrosive environments. This warranty does not cover stainless steel surfaces that have not been properly maintained.

NO OTHER WARRANTIES. VIKING MAKES NO WARRANTIES RELATING TO ITS PRODUCTS OTHER THAN AS DESCRIBED ABOVE AND DISCLAIMS ANY EXPRESS OR IMPLIED WARRANTIES OR MERCHANTABILITY OR FITNESS FOR ANY PARTICULAR PURPOSE.

EXCLUSION OF CONSEQUENTIAL DAMAGES. VIKING SHALL NOT, UNDER ANY CIRCUMSTANCES, BE LIABLE TO PURCHASER, OR ANY OTHER PARTY, FOR CONSEQUENTIAL, INCIDENTAL, SPECIAL OR EXEMPLARY DAMAGES ARISING OUT OF OR RELATED TO THE SALE OR USE OF THE PRODUCT SOLD HEREUNDER.

EXCLUSIVE REMEDY AND LIMITATION OF LIABILITY. WHETHER IN AN ACTION BASED ON CONTRACT, TORT (INCLUDING NEGLIGENCE OR STRICT LIABILITY) OR ANY OTHER LEGAL THEORY, ANY LIABILITY OF VIKING SHALL BE LIMITED TO REPAIR OR REPLACEMENT OF THE PRODUCT, OR AT VIKING'S OPTION, REFUND OF THE PURCHASE PRICE AS THE EXCLUSIVE REMEDY AND ANY LIABILITY OF VIKING SHALL BE SO LIMITED.

IT IS EXPRESSLY UNDERSTOOD AND AGREED THAT EACH AND EVERY PROVISION OF THIS AGREEMENT WHICH PROVIDES FOR DISCLAIMER OF WARRANTIES, EXCLUSION OF CONSEQUENTIAL DAMAGES, AND EXCLUSIVE REMEDY AND LIMITATION OF LIABILITY, ARE SEVERABLE FROM ANY OTHER PROVISION AND EACH PROVISION IS A SEPARABLE AND INDEPENDENT ELEMENT OF RISK ALLOCATION AND IS INTENDED TO BE ENFORCED AS SUCH.

Product Support: (715) 386-8666

Due to the dynamic nature of the product design, the information contained in this document is subject to change without notice. Viking Electronics, and its affiliates and/or subsidiaries assume no responsibility for errors and omissions contained in this information. Revisions of this document or new editions of it may be issued to incorporate such changes.