

VIKING PRODUCT MANUAL

COMMUNICATION & SECURITY SOLUTIONS

26-Bit Wiegand Keypad for Entry Systems

The **PRX-4** Keypad with Wiegand output allows keyless entry for select Viking apartment or office entry systems. The **PRX-4** Keypad features standard 26-bit Wiegand interfacing, a metal enclosure with potted electronics and a pigtail connection for indoor or outdoor applications.

The Keypad interfaces with the **AES-2000** Accessible Entry System. Up to 32 entry points with **PRX-4** Keypads may be added to the **AES-2000** by adding **ES-3** Controllers.

Alternatively, the **PRX-4** can be used with the **ES-1** Stand Alone Door Entry Controller, and the **C-4000** Four Door Entry Controller.

The **PRX-4** is equipped with Enhanced Weather Protection (**EWP**) for outdoor installations where the unit is exposed to precipitation or condensation. The **PRX-4** features a foam rubber gasket, sealed connections, as well as an epoxy potted circuit board. For more information, see **DOD# 859**.



Features

- Standard 26-bit Wiegand interface
- Designed for outdoor use, the **PRX-4** comes standard with Enhanced Weather Protection (**EWP**)
- **PRX-4** is designed to meet IP66 Ingress Protection Rating (see **DOD# 859**)
- Pigtail connection for easy installation
- Bi-color LED shows activity
- Screw protection caps
- Beep tones acknowledge key strokes
- Programmable Facility Code stored in non-volatile memory (no batteries required)

Applications

- Compatible with these Viking products:

Model	Description	DOD#
AES-2000	Accessible Entry System	202
AES-2005	Accessible Video Entry System	204
C-4000	Apartment / Office Entry Controller	164
ES-1	Stand Alone Keyless Entry System	193
ES-3	Entry System Door Controller	195

Specifications

Power: 12-28V DC, 30mA - average
Dimensions: 181mm x 43mm x 20mm (7.1" x 1.7" x 0.5")
Shipping weight: 0.45 kg (1 lb)
Environmental: -40° C to 70° C (-40° F to 158° F) with up to 100% humidity
Connections: 8" long pigtail leads, 22 gauge

www.vikingelectronics.com
Information: (715) 386-8861

Installation

IMPORTANT: Electronic devices are susceptible to lightning and power station electrical surges from both the AC outlet and the telephone line. It is recommended that a surge protector be installed to protect against such surges.

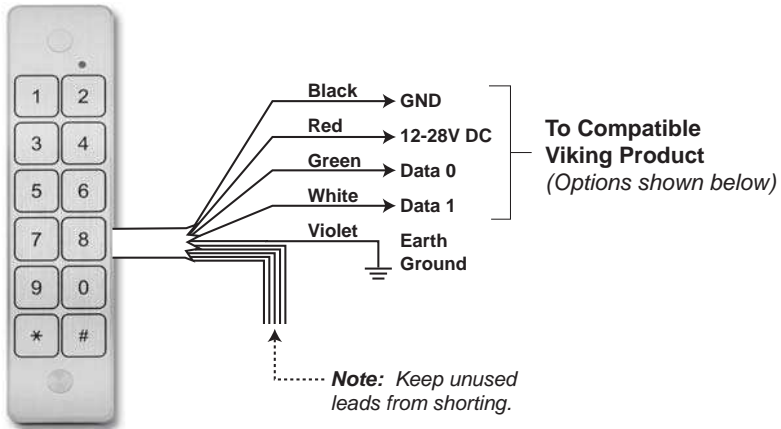

Compatible Viking Products



Apartment Entry System with Accessibility Features

The **AES-2000** Accessible Entry System provides both audio and visual assistance for those with disabilities. The LCD display with large 1/2" tall characters is back-lit and will display a directory of tenants as well as directions and prompts. The unit is available in **AES-2000F** flush mount and **AES-2000S** surface mount, see **DOD# 202**. Models also available with a built in video camera: **AES-2005F** and **AES-2005S**, see **DOD# 204**.



Provide 4 Door Entry Points with Keyless Entry, or Optional Card Readers, for up to 250 Apartments or Offices

The **C-4000** converts any four touch tone phones into multi-number auto dialers that will store up to 250 telephone numbers in non-volatile memory. When a call initiated by the **C-4000** is answered by an apartment or business tenant, a built-in contact closure may be activated to control an electric gate or door strike. See **DOD# 164** for more info.



Stand Alone Door Controller Entry System

The **ES-1** is a door controller designed to operate a door strike or magnetic lock upon receiving a valid card read and/or keyless entry code from Wiegand devices. One **ES-1**, one or two Wiegand devices and a door strike or magnetic lock of your choice is required for each entry point. All programming is done with a local touch tone phone and is stored in non-volatile memory. See **DOD# 193** for more information.



Add Up To 32 Access Entry Points to an AES-2000

Up to 32 additional points of entry can be added to **Viking's** model **AES-2000** Accessible Entry System. One **ES-3**, one Wiegand device and a door strike or magnetic lock of your choice is required for each additional entry point. The **ES-3** is an entry system door controller designed to operate a door strike or magnetic lock upon receiving a valid card read from a Wiegand device. See **DOD# 195** for more information.

Programming

The **PRX-4** is factory programmed with the facility code cleared (000). To program a facility code, press “*” during the first 3 seconds from when the unit powers up. Then (within 10 seconds) enter any number 000 to 255 as its facility code, followed by “#”.

Operation

The red LED on the front of the **PRX-4** will light steady to show the keypad is powered up, and blink yellow with each key stroke. A beep tone will also acknowledge each time a key is pressed. To gain access, enter the keyless entry code, followed by the “#” key.

Important: 26-bit Wiegand data limits the entry code range from 00001 to 65534.

Warning: Do not program the Viking **ES-1**, **C-4000**, **AES-2000** or any other entry system to accept code number 65535. The **PRX-4** keypad outputs 65535 as an error code. An error code is given if one of these three sequences happen:

1. Pressing the “#” key with no preceding digits.
2. Pressing any number of only zeros prior to pressing the “#” key.
3. Pressing 65535 or any number above 65535.

Warranty

IF YOU HAVE A PROBLEM WITH A VIKING PRODUCT, CONTACT: VIKING TECHNICAL SUPPORT AT (715) 386-8666

Our Technical Support Department is available for assistance Monday 8am - 4pm and Tuesday through Friday 8am - 5pm central time. So that we can give you better service, before you call please:

1. Know the model number, the serial number and what software version you have (see serial label).
2. Have your Technical Practice in front of you.
3. It is best if you are on site.

RETURNING PRODUCT FOR REPAIR

The following procedure is for equipment that needs repair:

1. Customer must contact Viking's Technical Support Department at 715-386-8666 to obtain a Return Authorization (RA) number. The customer **MUST** have a complete description of the problem, with all pertinent information regarding the defect, such as options set, conditions, symptoms, methods to duplicate problem, frequency of failure, etc.
2. Packing: Return equipment in original box or in proper packing so that damage will not occur while in transit. Static sensitive equipment such as a circuit board should be in an anti-static bag, sandwiched between foam and individually boxed. All equipment should be wrapped to avoid packing material lodging in or sticking to the equipment. Include ALL parts of the equipment. C.O.D. or freight collect shipments cannot be accepted. Ship cartons prepaid to: **Viking Electronics, 1531 Industrial Street, Hudson, WI 54016**
3. Return shipping address: Be sure to include your return shipping address inside the box. We cannot ship to a PO Box.
4. RA number on carton: In large printing, write the R.A. number on the outside of each carton being returned.

RETURNING PRODUCT FOR EXCHANGE

The following procedure is for equipment that has failed out-of-box (within 10 days of purchase):

1. Customer must contact Viking's Technical Support at 715-386-8666 to determine possible causes for the problem. The customer **MUST** be able to step through recommended tests for diagnosis.
2. If the Technical Support Product Specialist determines that the equipment is defective based on the customer's input and troubleshooting, a Return Authorization (R.A.) number will be issued. This number is valid for fourteen (14) calendar days from the date of issue.
3. After obtaining the R.A. number, return the approved equipment to your distributor, referencing the R.A. number. Your distributor will then replace the product over Viking using the same R.A. number.
4. **The distributor will NOT exchange this product without first obtaining the R.A. number from you. If you haven't followed the steps listed in 1, 2 and 3, be aware that you will have to pay a restocking charge.**

LIMITED WARRANTY

Viking warrants its products to be free from defects in the workmanship or materials, under normal use and service, for a period of one year from the date of purchase from any authorized Viking distributor or 18 months from the date manufactured, which ever is greater. If at any time during the warranty period, the product is deemed defective or malfunctions, return the product to Viking Electronics, Inc., 1531 Industrial Street, Hudson, WI., 54016. Customer must contact Viking's Technical Support Department at 715-386-8666 to obtain a Return Authorization (R.A.) number.

This warranty does not cover any damage to the product due to lightning, over voltage, under voltage, accident, misuse, abuse, negligence or any damage caused by use of the product by the purchaser or others. This warranty does not cover non-EWP products that have been exposed to wet or corrosive environments.

NO OTHER WARRANTIES. VIKING MAKES NO WARRANTIES RELATING TO ITS PRODUCTS OTHER THAN AS DESCRIBED ABOVE AND DISCLAIMS ANY EXPRESS OR IMPLIED WARRANTIES OR MERCHANTABILITY OR FITNESS FOR ANY PARTICULAR PURPOSE.

EXCLUSION OF CONSEQUENTIAL DAMAGES. VIKING SHALL NOT, UNDER ANY CIRCUMSTANCES, BE LIABLE TO PURCHASER, OR ANY OTHER PARTY, FOR CONSEQUENTIAL, INCIDENTAL, SPECIAL OR EXEMPLARY DAMAGES ARISING OUT OF OR RELATED TO THE SALE OR USE OF THE PRODUCT SOLD HEREUNDER.

EXCLUSIVE REMEDY AND LIMITATION OF LIABILITY. WHETHER IN AN ACTION BASED ON CONTRACT, TORT (INCLUDING NEGLIGENCE OR STRICT LIABILITY) OR ANY OTHER LEGAL THEORY, ANY LIABILITY OF VIKING SHALL BE LIMITED TO REPAIR OR REPLACEMENT OF THE PRODUCT, OR AT VIKING'S OPTION, REFUND OF THE PURCHASE PRICE AS THE EXCLUSIVE REMEDY AND ANY LIABILITY OF VIKING SHALL BE SO LIMITED.

IT IS EXPRESSLY UNDERSTOOD AND AGREED THAT EACH AND EVERY PROVISION OF THIS AGREEMENT WHICH PROVIDES FOR DISCLAIMER OF WARRANTIES, EXCLUSION OF CONSEQUENTIAL DAMAGES, AND EXCLUSIVE REMEDY AND LIMITATION OF LIABILITY, ARE SEVERABLE FROM ANY OTHER PROVISION AND EACH PROVISION IS A SEPARABLE AND INDEPENDENT ELEMENT OF RISK ALLOCATION AND IS INTENDED TO BE ENFORCED AS SUCH.

Product Support: (715) 386-8666

Due to the dynamic nature of the product design, the information contained in this document is subject to change without notice. Viking Electronics, and its affiliates and/or subsidiaries assume no responsibility for errors and omissions contained in this information. Revisions of this document or new editions of it may be issued to incorporate such changes.