



TECHNICAL Practice

TELECOM SOLUTIONS FOR THE 21ST CENTURY

PRX-1
<i>Proximity Card Reader</i>
November 22, 2013

125KHz Proximity Card Readers for Door Access, Gate Entry and Parking Barriers

The model **PRX-1** is a 125KHz proximity card reader and is designed to be mounted directly to a metal door or window frame (mullions), making it ideal for applications requiring an access credential. The proximity card reader transmits data in 26-Bit Wiegand format, making it compatible with any of the Wiegand equipped Viking entry controllers.

The **PRX-1** delivers non-contact read ranges up to 6 inches (152 mm), and operates from 5 to 14 VDC. Mounting is simplified with horizontal and vertical mounting slots, which allow the reader to be conveniently adjusted and leveled. Concealing the mounting hardware, the **PRX-1** ships with both Black and Ash (Off-White) covers standard.

The **PRX-1** is equipped with Enhanced Weather Protection (**EWP**) for outdoor installations where the unit is exposed to precipitation or condensation. The **PRX-1** features sealed connections, as well as an epoxy potted circuit board. For more information, see **DOD# 859**.



Features

- Read range of up to 6 inches
- Standard 26-bit Wiegand interface
- Technologies supported: Viking **PRX-C**, **PRX-C-ISO**, **PRX-FOB** and certain legacy HID® proximity protocols*
- Compact size allows mounting to mullion, door or window frame
- Designed for outdoor use, the **PRX-1** comes standard with Enhanced Weather Protection (**EWP**) (see **DOD# 859**)
- **PRX-1** is designed to meet IP66 Ingress Protection Rating (see **DOD# 859**)
- Pigtail connection for easy installation
- Red LED indicates power and flashes off during card read
- Transducer provides beep during card read

* HID and the HID logo are registered trademarks of HID Global Corporation, an ASSA ABLOY company. All other trademarks are the property of their respective owners.

Applications

Compatible with these Viking products:

Model	DOD#	Description
AES-2000	202	Accessible Entry System
AES-2005	204	Accessible Entry System with Video
C-4000	164	Apartment/Office Controller
ES-1	193	Stand Alone Keyless Entry System
PRX-C	198	Proximity Card
PRX-C-ISO	198	Thin Proximity Card
PRX-FOB	198	Proximity Key Fob

Information: 715.386.8861

Specifications

Power: 5-14V DC, 45mA - average, 80mA - peak
Dimensions: 80mm x 43mm x 17mm (3.2" x 1.7" x 0.7")
Shipping weight: 0.45 kg (1 lb)
Environmental: -40° C to 65° C (-40° F to 150° F) with 5% to 95% non-condensing humidity
Connections: 18" long pigtail leads, 24 gauge
Technologies Supported: Viking **PRX-C**, **PRX-C-ISO**, **PRX-FOB** and certain legacy HID® proximity protocols*

IF YOU HAVE A PROBLEM WITH A VIKING PRODUCT PLEASE CONTACT: VIKING TECHNICAL SUPPORT AT (715) 386-8666

Our Technical Support Department is available for assistance Monday 8am - 4pm and Tuesday to Friday 8am - 5pm central standard time. So that we can give you better service, before you call please:

1. Know the model number, the serial number and what software version you have (see serial label).
2. Have your Technical Practice in front of you.
3. It is best if you are on site.

RETURNING PRODUCT FOR REPAIR

The following procedure is for equipment that needs repair:

1. Customer must contact Viking's Technical Support Department at 715-386-8666 to obtain a Return Authorization (RA) number. The customer MUST have a complete description of the problem, with all pertinent information regarding the defect, such as options set, conditions, symptoms, methods to duplicate problem, frequency of failure, etc.
2. Packing: Return equipment in original box or in proper packing so that damage will not occur while in transit. Static sensitive equipment such as a circuit board should be in an anti-static bag, sandwiched between foam and individually boxed. All equipment should be wrapped to avoid packing material lodging in or sticking to the equipment. Include ALL parts of the equipment. C.O.D. or freight collect shipments cannot be accepted. Ship cartons prepaid to: **Viking Electronics, 1531 Industrial Street, Hudson, WI 54016**
3. Return shipping address: Be sure to include your return shipping address inside the box. We cannot ship to a P.O. Box.
4. RA number on carton: In large printing, write the R.A. number on the outside of each carton being returned.

RETURNING PRODUCT FOR EXCHANGE

The following procedure is for equipment that has failed out-of-box (within 10 days of purchase):

1. Customer must contact Viking's Technical Support at 715-386-8666 to determine possible causes for the problem. The customer MUST be able to step through recommended tests for diagnosis.
2. If the Technical Support Product Specialist determines that the equipment is defective based on the customer's input and troubleshooting, a Return Authorization (R.A.) number will be issued. This number is valid for fourteen (14) calendar days from the date of issue.
3. After obtaining the R.A. number, return the approved equipment to your distributor, referencing the R.A. number. Your distributor will then replace the product over the counter at no charge. The distributor will then return the product to Viking using the same R.A. number.
4. **The distributor will NOT exchange this product without first obtaining the R.A. number from you. If you haven't followed the steps listed in 1, 2 and 3, be aware that you will have to pay a restocking charge.**

LIMITED WARRANTY

Viking warrants its products to be free from defects in the workmanship or materials, under normal use and service, for a period of one year from the date of purchase from any authorized Viking distributor or 18 months from the date manufactured, which ever is greater. If at any time during the warranty period, the product is deemed defective or malfunctions, return the product to Viking Electronics, Inc., 1531 Industrial Street, Hudson, WI., 54016. Customer must contact Viking's Technical Support Department at 715-386-8666 to obtain a Return Authorization (R.A.) number.

This warranty does not cover any damage to the product due to lightning, over voltage, under voltage, accident, misuse, abuse, negligence or any damage caused by use of the product by the purchaser or others.

NO OTHER WARRANTIES. VIKING MAKES NO WARRANTIES RELATING TO ITS PRODUCTS OTHER THAN AS DESCRIBED ABOVE AND DISCLAIMS ANY EXPRESS OR IMPLIED WARRANTIES OR MERCHANTABILITY OR FITNESS FOR ANY PARTICULAR PURPOSE.

EXCLUSION OF CONSEQUENTIAL DAMAGES. VIKING SHALL NOT, UNDER ANY CIRCUMSTANCES, BE LIABLE TO PURCHASER, OR ANY OTHER PARTY, FOR CONSEQUENTIAL, INCIDENTAL, SPECIAL OR EXEMPLARY DAMAGES ARISING OUT OF OR RELATED TO THE SALE OR USE OF THE PRODUCT SOLD HEREUNDER.

EXCLUSIVE REMEDY AND LIMITATION OF LIABILITY. WHETHER IN AN ACTION BASED ON CONTRACT, TORT (INCLUDING NEGLIGENCE OR STRICT LIABILITY) OR ANY OTHER LEGAL THEORY, ANY LIABILITY OF VIKING SHALL BE LIMITED TO REPAIR OR REPLACEMENT OF THE PRODUCT, OR AT VIKING'S OPTION, REFUND OF THE PURCHASE PRICE AS THE EXCLUSIVE REMEDY AND ANY LIABILITY OF VIKING SHALL BE SO LIMITED.

IT IS EXPRESSLY UNDERSTOOD AND AGREED THAT EACH AND EVERY PROVISION OF THIS AGREEMENT WHICH PROVIDES FOR DISCLAIMER OF WARRANTIES, EXCLUSION OF CONSEQUENTIAL DAMAGES, AND EXCLUSIVE REMEDY AND LIMITATION OF LIABILITY, ARE SEVERABLE FROM ANY OTHER PROVISION AND EACH PROVISION IS A SEPARABLE AND INDEPENDENT ELEMENT OF RISK ALLOCATION AND IS INTENDED TO BE ENFORCED AS SUCH.

PART 15 LIMITATIONS

This equipment has been tested and found to comply with the limits for a Class A digital device, pursuant to Part 15 of the FCC Rules. These limits are designed to provide reasonable protection against harmful interference when the equipment is operated in a commercial environment. This equipment generates, uses, and can radiate radio frequency energy and, if not installed and used in accordance with the instruction manual, may cause harmful interference to radio communications. Operation of this equipment in a residential area is likely to cause harmful interference in which case the user will be required to correct the interference at his own expense.

Requirements

Cable Requirements:

The **PRX-1** can operate at up to *500 feet (152 m) of cable, using seven-conductor, shielded, stranded cable. Per the Security Industry Association's Wiegand specification, AWG 24 (such as Belden 9537) is the minimum gauge required for data transfer in a 500-foot run length. However, the proper wire gauge to use must be determined by the current draw requirements of the reader, the length of the cable run, and the voltage applied to the reader.

If the reader is to be operated at 5 VDC, 5 VDC must be available at the reader (long cable runs have a voltage drop due to the resistance in the cable). A larger gauge of wire (having less resistance) or a separate power supply near the reader may be required to ensure 5 VDC is available at the reader.

Output Formats:

- Wiegand (industry standard 26-bit Wiegand)
- Magnetic Stripe (ABA Track II, clock and data, with card present)

Grounding:

Shield (drain) continuity must run from the reader to the access panel. Shield (drain) and reader ground must be tied together at the access panel and connect to an earth ground at one point.

Power:

The **PRX-1** may be powered by the access panel. As such, the reader is powered on when the access panel is powered on. However the best case is to power the reader by a separate, linear power supply.

Voltage: 5 to 14 VDC **Note:** For maximum read range, a minimum of 12VDC is recommended.

FleaPower™ Control Line:

The **PRX-1** can be placed in a special lower power mode by pulling the purple colored fleaPower Control Line low. This special low power mode reduces the average power required by the reader.

* **Note:** When used with a Viking Entry System/Controller, see the Entry System's Product Manual for the maximum wire run length.

Installation

Note 1: Read range is stated in a clean RF and electrical environment using Viking proximity cards presented parallel to the reader surface with the reader operating at 12 VDC. Additionally, read range may be affected by local installation conditions. Range will be less when mounted to metal.

Note 2: Use of a linear power supply is always recommended.

Note 3: Minimum current draw is obtained by operating the reader in the fleaPower mode at 5 VDC with the LED off. Peak current draw occurs when reading a card or tag.

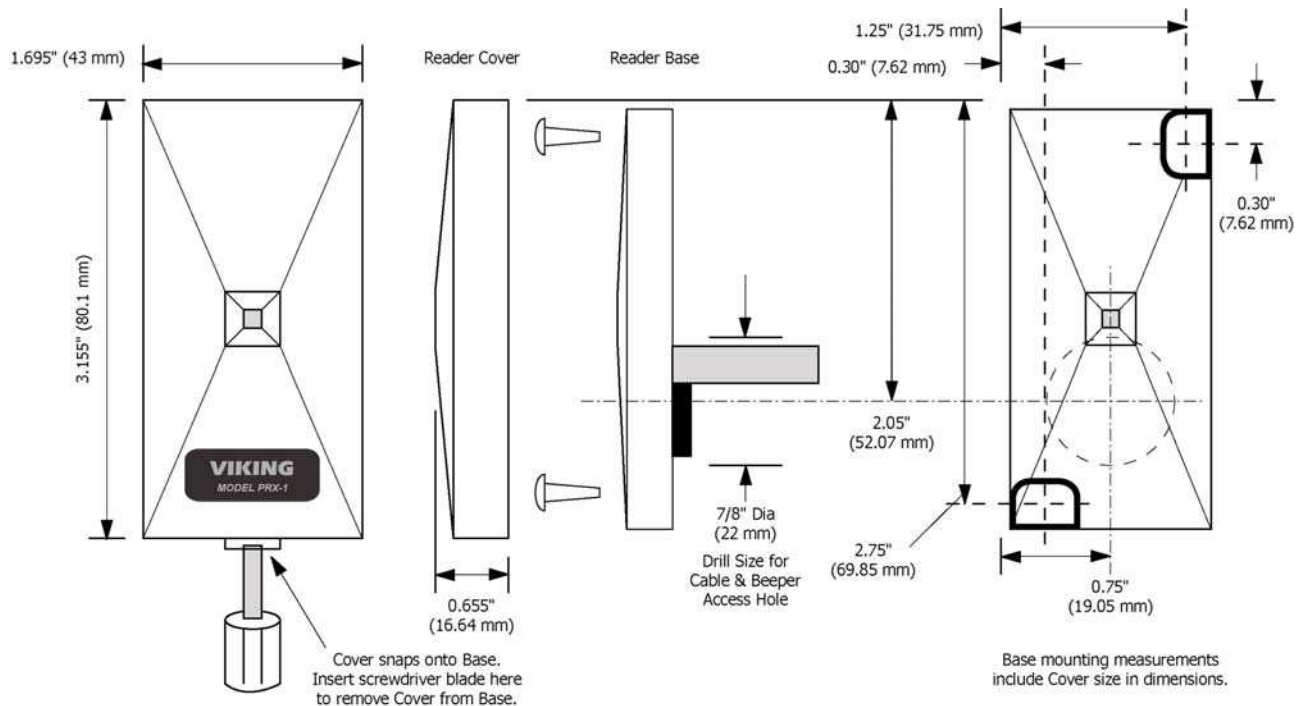

Wiring

IMPORTANT: Electronic devices are susceptible to lightning and power station electrical surges from both the AC outlet and the telephone line. It is recommended that a surge protector be installed to protect against such surges.

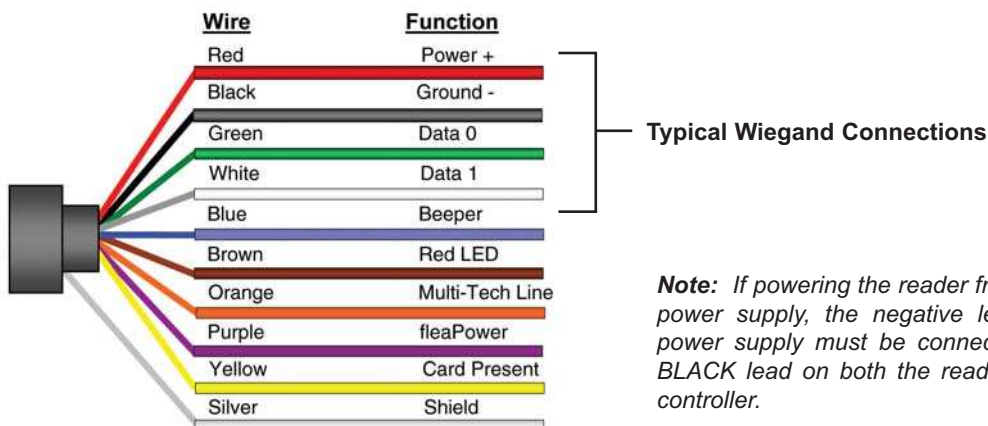

Troubleshooting

1. When the reader is powered up a victory beep (4-quick beeps) is heard and the LED stays Red.
2. Present the correct card and the reader will beep once and LED will flash on and off. It is up to the control panel to control dual LED and have the LED turn green when an enrolled card is presented.

If reader does not recognize the card/tag (no beep, no LED flash) or reader has short read range, please see table below for possible causes and solutions.

Possible Cause	Corrective Action
Incorrect wiring	Verify wiring connection
Not enough power	12 VDC suggested
Mounted near electromagnetic interference	Relocate or provide greater separation from
Incorrect card used	Verify card compatibility from model number
Reader/access panel not properly grounded	Quality Earth Ground needed. Verify shield line from the access panel to the reader is one continuous, connected line.
Supply generating electromagnetic interference	Linear power supply recommended

If any of the corrective actions mentioned above don't work, please disconnect the reader from panel and power it with a separate power supply or 9V battery and test card functionality. By powering it individually and off the installation most variables that can cause malfunction are eliminated. If after the reader is powered by a separate power source the failure persist, please contact Viking Electronics Product Support.

Product Support Line...715.386.8666

Fax Back Line...715.386.4345

Due to the dynamic nature of the product design, the information contained in this document is subject to change without notice. Viking Electronics, and its affiliates and/or subsidiaries assume no responsibility for errors and omissions contained in this information. Revisions of this document or new editions of it may be issued to incorporate such changes.