

Add Location Announcement to Emergency Phones

The **EV-1** is the perfect solution to help make your elevator/emergency phone A.D.A.* compliant.

The **EV-1** is a line powered emergency voice announcer designed to add a natural voice announcement to any telephone. The announcer provides ten seconds of non-volatile record time that can be used to communicate the location of an emergency phone, or a piece of malfunctioning equipment.



**Americans with Disabilities Act of 1992 contains new federal regulations regarding elevator telephones (Public Law 101-336).*

After a call initiated behind the **EV-1** is answered, the **EV-1** repeats the announcement continuously. Emergency personnel can stop and start the announcement at will by dialing a Touch Tone *.

<http://VikingElectronics.com>

[E-mail...Info@VikingElectronics.com](mailto:Info@VikingElectronics.com)

Features

- Telephone line powered
- Ten seconds of digital record time
- Non-volatile memory (no batteries required)
- Record remotely or locally with a Touch Tone phone
- Automatic playback capability

Made in the U.S.A. Specifications

Power: Phone line powered (32V DC 25mA minimum)
Dimensions: 71mm x 36mm x 119mm (2.8" x 1.4" x 4.7")
Shipping Weight: 0.7 kg (1.5 lb)
Environmental: 0° C to 32° C (32° F to 90° F) with 5% to 95% non-condensing humidity
Sampling Rate: 64K (equivalent)
Message Length: 10 Seconds
Connections: (2) RJ11 jacks

Applications

- Emergency/elevator phone location identification (helps meet A.D.A. requirements)
- Identify calls initiated by automatic dialing equipment

Sales...(715) 386-8861

Installation

1. Plug the central office line or analog PABX/KSU extension into the RJ-11 jack labeled **LINE IN**.
2. Plug the calling device into the RJ11 jack labeled **TO PHONE**.

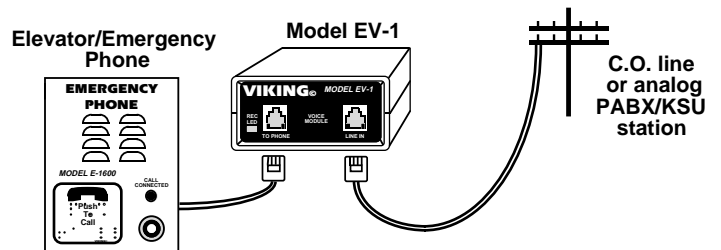

Programming/Recording

A. Dip Switch Settings

Switch 1	Repeat Time
ON	8 seconds between announcements
OFF	3 seconds between announcements

Switch 2	Local Recording
ON	Enable
OFF	Disable

Switch 3	Remote Recording
ON	Enable
OFF	Disable

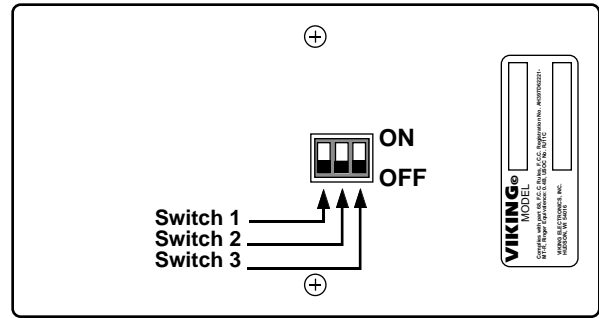

B. Recording

The **EV-1** may be recorded locally or remotely. Before recording, it is recommended that a script be written and timed. There is 10 seconds of voice record time available. The script should contain information about the location of the emergency call as well as how to start and stop the announcement.

Example: "Elevator number 1215, located in the Trade Center Building needs assistance. Press the star key on your telephone to stop and start this announcement."

1. Local Recording

- Connect the **LINE IN** jack to a telephone line or analog PABX/KSU extension.
- Set dip **Switch 2** to the **ON** position.
- Connect a standard Touch Tone telephone into the **TO PHONE** jack.
- Take the phone off-hook and dial a Touch Tone **1**. Start recording your announcement after hearing two beeps. Dial a **4** to play back the recording.
- When the ten seconds of record time has expired, the LED will go off and you will hear two more beeps. If your announcement is less than 10 seconds in length, set dip **Switch 2** to the **OFF** position to stop the recording.

2. Remote Recording

- Install the **EV-1** as shown in the **Installation** section.
- Set dip **Switch 2** to the **OFF** position and dip **Switch 3** to the **ON** position.
- From a Touch Tone telephone connected to a second telephone line, call the telephone line connected to the **EV-1**.
- When the line is answered, dial **732 (R-E-C)**.
Note: A phone or device must either automatically answer or be manually answered.
- Then dial **1**.
- Begin recording your announcement after a double beep is heard. Dial **4** to play back the recording.
- Hang-up when finished.
Note: To prevent unintentional recordings, set dip **Switch 3** to the **OFF** position.

Operation

When an outbound call is initiated, the **EV-1** remains silent and monitors for precise ring back tones. After the **EV-1** has determined that the call has been answered (5 - 10 seconds), it begins repeating the recorded announcement continuously. You may then stop the announcement at any time with a Touch Tone *****. Upon detecting the *****, the **EV-1** will play the remainder of the announcement in progress, and then stop. When the announcement has stopped, the emergency personnel may communicate with the person at the emergency phone. The announcement may be started again by pressing the *****.

Product Support Line...(715) 386-8666

Fax Back Line...(715) 386-4345

Due to the dynamic nature of the product design, the information contained in this document is subject to change without notice. Viking Electronics, its affiliates and/or subsidiaries assume no responsibility for errors and/or omissions contained in this information. Revisions of this document or new editions of it may be issued to incorporate such changes.