



TECHNICAL Practice

TELECOM SOLUTIONS FOR THE 21ST CENTURY

ERAM-60

Memory Expansion Kit for the DVA-2W, DVA-500A, DVA-1003B, DVA-3003 and FBI-1A

May 7, 2001

Expand the Voice Record Time of Viking Products



The **ERAM-60** Memory Expansion Kit is designed to expand the voice record memory of specified Viking products using non-volatile memory.

Each kit includes one 28 pin non-volatile memory chip which provides one minute of record time. The number of chips required is dependant on the record time required and the capacity of the announcer.

Model	# of Kits	Factory Record Time	Maximum Record Time
DVA-2W	up to 3	1 minute	4 minutes
DVA-500A	1	16 seconds	1 minute
DVA-1003B	up to 3	16 seconds per channel	1 minute
DVA-3003	up to 9	1 minute per channel (3 minutes total)	4 minutes per channel (12 minutes total)
FBI-1A	1	16 seconds	1 minute

Installation

A. DVA-2W Memory Expansion

Important: Electronics componants are sensitive to static electricity. Personnel and the work area should be grounded before handling.

1. Disconnect the power to the **DVA-2W**.
2. Remove the (2) screws on the bottom of the unit, then remove the cover.
3. Insert the **ERAM** chip(s) carefully into the appropriate socket(s) with the indents facing in the direction shown in the diagram below.
4. Replace the cover and screws of the **DVA-2W**.

Specifications

Environmental: 0° C to 32° C (32° F to 90° F) with 5% to 95% non-condensing humidity

Description: (1) 28-pin ERAM chip (1 minute of record time)

Phone...715.386.8861

info@vikingelectronics.com

http://www.vikingelectronics.com

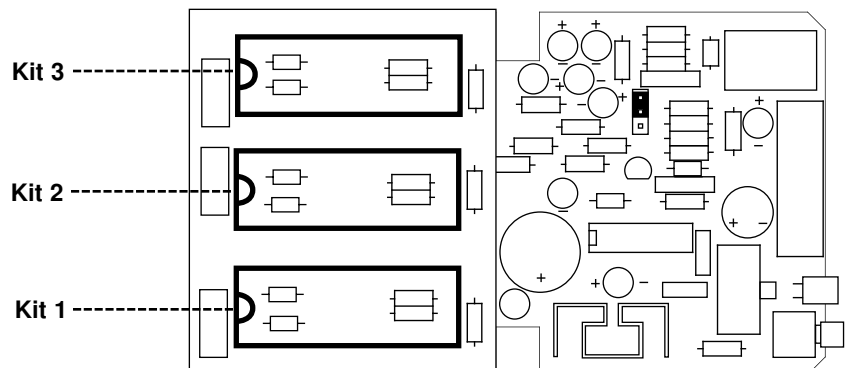
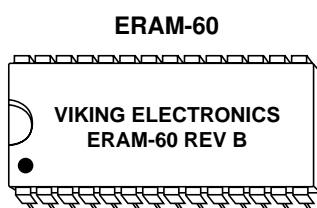

Installation

B. DVA-500A and DVA-1003B Memory Expansion

Important: Electronics components are sensitive to static electricity. Personnel and the work area should be grounded before handling.

1. Disconnect the power and telecom connections to the **DVA-500A** or **DVA-1003B**.
2. Remove the (4) screws on the bottom of the unit, then remove the cover.
3. Insert the **ERAM** chip(s) carefully into the appropriate socket(s) with the indents facing in the direction shown.
4. Replace the cover and screws of the **DVA-500A** or **DVA-1003B**.

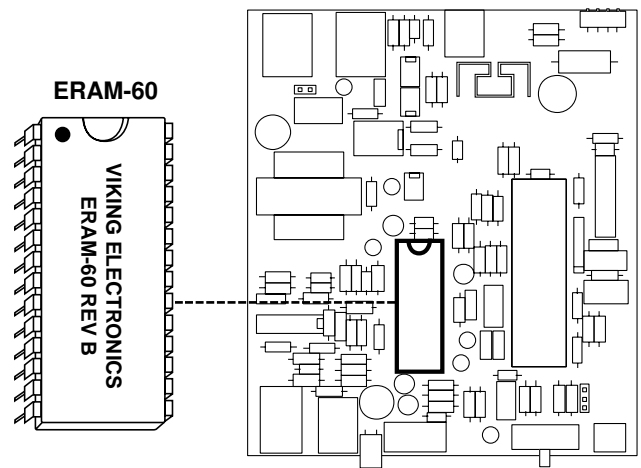

C. DVA-3003 Memory Expansion

Important: Electronics components are sensitive to static electricity. Personnel and the work area should be grounded before handling.

1. Disconnect the power and telecom connections to the **DVA-3003**.
2. Remove the (4) screws on the bottom of the unit, then remove the cover.
3. Insert the **ERAM** chip(s) carefully into the appropriate socket(s) with the indents facing in the direction shown below.
4. Replace the cover and screws of the **DVA-3003**.

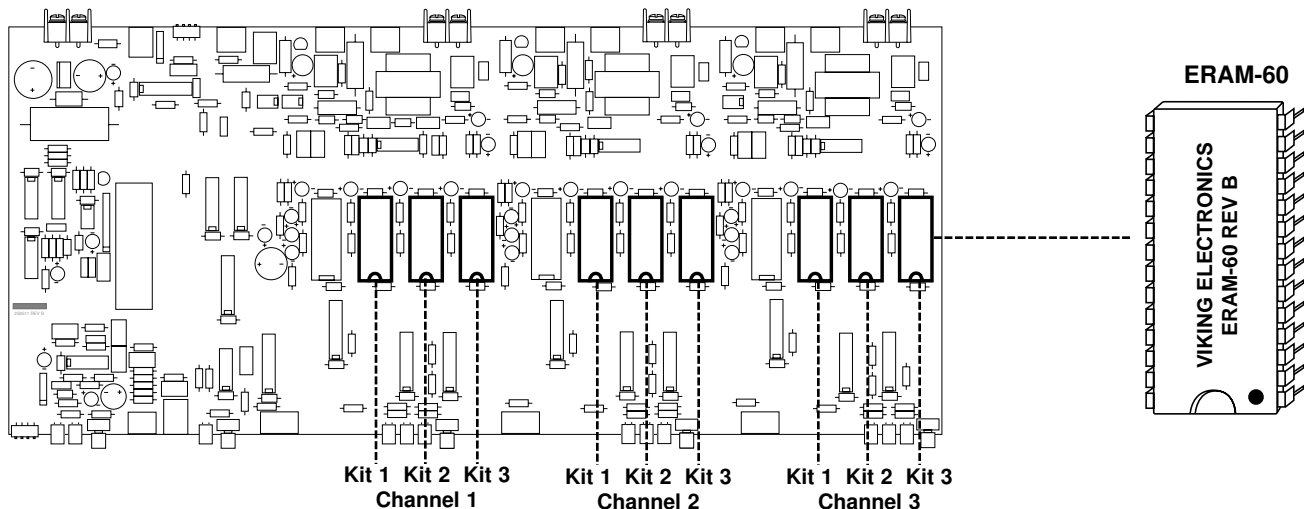

D. FBI-1A Memory Expansion

Important: Electronics components are sensitive to static electricity. Personnel and the work area should be grounded before handling.

1. Disconnect the power and telecom connections to the **FBI-1A**.
2. Remove the circuit board by spreading the aluminum housing until the board is free.
3. Insert the **ERAM** chip(s) carefully into the appropriate socket(s) with the indents facing in the direction shown.
4. Place the board back into the chassis of the **FBI-1A**.

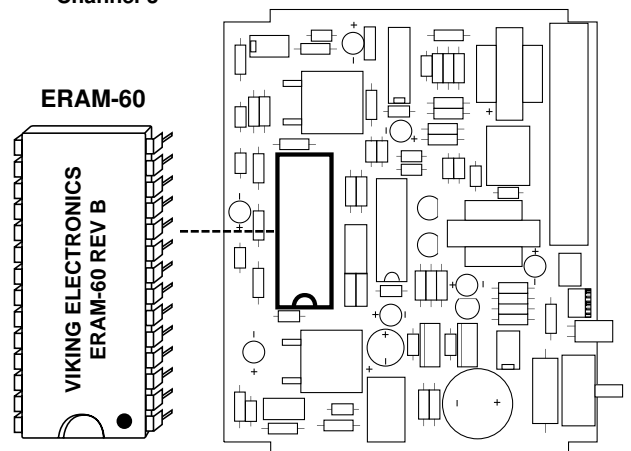

Product Support Line...715.386.8666

Fax Back Line...715.386.4345

Due to the dynamic nature of the product design, the information contained in this document is subject to change without notice. Viking Electronics, and its affiliates and/or subsidiaries assume no responsibility for errors and omissions contained in this information. Revisions of this document or new editions of it may be issued to incorporate such changes.