

VIKING PRODUCT MANUAL

COMMUNICATION & SECURITY SOLUTIONS

Gooseneck Pedestal Mounting Kit for the E-1600A, E-1600-45A, E-1600-60A and E-1600-65A

The model **E-1600A-MK-GNP** is a mounting kit for attaching the **E-1600A**, **E-1600-45A**, **E-1600-60A** or **E-1600-65A** Emergency Phone to a Viking **VE-GNP** gooseneck pedestal.

The kit includes stainless steel mounting hardware, two gaskets to seal the back of the Emergency Phone and a durable powder coated 12 gauge steel mounting plate.



E-1600A-MK-GNP Mounting Plate



**Model E-1600A
Emergency Phone
shown with VE-GNP
Pedestal and
E-1600A-MK-GNP
Mounting Kit**

Features

- **E-1600A-MK-GNP** allows the **E-1600A**, **E-1600-45A**, **E-1600-60A** or **E-1600-65A** Emergency Phone to be mounted directly to a Viking **VE-GNP** gooseneck pedestal
- Durable 12 gauge steel mounting plate
- Plate is powder coat primed then top coated with a UV stable black textured powder coat
- Stainless steel mounting hardware is included
- Two gaskets are included for sealing the back of the Emergency Phone to the gooseneck pedestal

Applications

- For mounting the following Viking Emergency Phones to a Viking **VE-GNP** gooseneck pedestal for emergency pool phone applications etc.
 - **E-1600A** Red Emergency Phone
 - **E-1600-45A** Yellow Emergency Phone
 - **E-1600-60A** "Police" Emergency Phone
 - **E-1600-65A** Blue Emergency Phone

For more information on Viking Emergency Phones, see DOD# 215

Specifications

Dimensions: 136.4mm x 86.4mm x 2.67mm (5.37" x 3.40" x 0.105")

Shipping Weight: 0.544 kg (1.2 lbs)

Environmental: -40°C to 65°C (-40°F to 150°F) with up to 100% humidity

Included Hardware: (4) #10-24 x 5/8 stainless steel truss head screws, (4) 10-24 stainless steel nylock nuts

www.vikingelectronics.com

Information: (715) 386-8861

Installation

Step 1.	Adhere the square gasket to the E-1600A-MK-GNP mounting plate. Make sure gasket is centered and holes align. (Figure 1)
Step 2.	Adhere the rectangular gasket to the other side of the E-1600A-MK-GNP mounting plate. Make sure gasket is centered and holes and arrow symbol align. (Figure 1)
Step 3.	Place the E-1600A back plate on the rectangular gasket side of the E-1600A-MK-GNP mounting plate. Pull the wires through the center hole on the plates. Make sure the arrow symbol on the E-1600A-MK-GNP mounting plate is pointing UP then attach the square gasket side of the plate to the VE-GNP pedestal mounting plate with the 4 truss head screws and nylock nuts as shown. Do not tighten screws until all 4 screws are inserted and plate is aligned. (Figure 2)
Step 4.	Attach the wires from the pedestal to the E-1600A with provided butt connectors then fasten the E-1600A to mounting plate by tightening the set screw on the bottom of the unit.

Figure 1

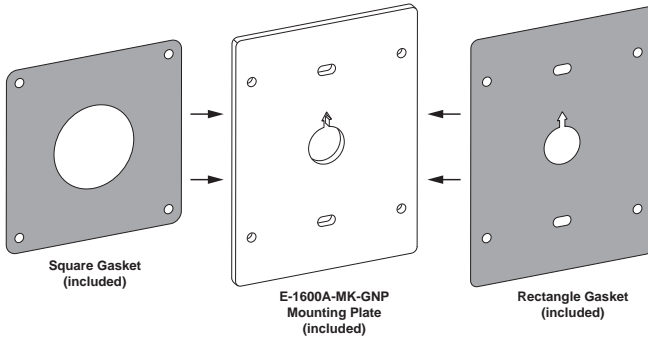
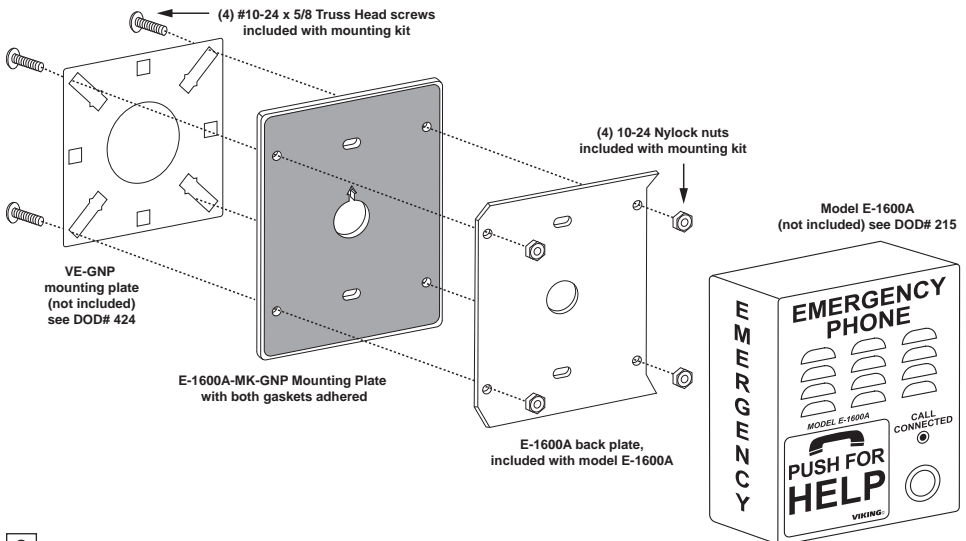

Figure 2



1600A Series Emergency Phones



E-1600-65A
Emergency Blue



E-1600-45A
Safety Yellow



E-1600-60A
Police Blue



E-1600A
Emergency Red

The **1600A Series** ADA Compliant Emergency Phones are designed to provide quick and reliable hands-free communication for any standard analog telephone line or analog phone system station port. All **1600A Series** phones meet ADA requirements for elevator/emergency telephones, and can be programmed from any Touch Tone phone. The phones can dial up to 5 programmable emergency numbers, as well as 2 central station numbers.

The **1600A Series** phones can be programmed to automatically deliver a digital announcement to identify the location of the emergency call. Alternatively, a DTMF Touch Tone code may also be delivered. A "Call Connected" LED can be initiated manually or automatically. All programming parameters, including phone numbers and location numbers, are stored in non-volatile memory. All units are phone line powered, requiring no batteries or external power and are compatible with common Central Station Monitoring equipment.

For outdoor installations where the unit is exposed to precipitation or condensation, select **1600A Series** phones are available with Enhanced Weather Protection (EWP).

For more information on the Viking 1600A Series, see DOD# 215.

Gooseneck Pedestals

Viking's gooseneck pedestals are designed to be compatible with Viking products. Model **VE-GNP** is a 42" tall, pad mount, black powder paint gooseneck pedestal. Model **VE-GNP-SS** is a 42" tall, pad mount, 304 brushed stainless steel gooseneck pedestal. The **VE-GNP-IG** is a 64" tall, in-ground mount, black powder paint gooseneck pedestal. Model **VE-GNP-2** is a 42"/72" dual height, pad mount, black powder paint gooseneck pedestal.

For more information on Viking Gooseneck Pedestals, see DOD# 424.



Warranty

IF YOU HAVE A PROBLEM WITH A VIKING PRODUCT, CONTACT: VIKING TECHNICAL SUPPORT AT (715) 386-8666

Our Technical Support Department is available for assistance Monday 8am - 4pm and Tuesday through Friday 8am - 5pm central time. So that we can give you better service, before you call please:

1. Know the model number, the serial number and what software version you have (see serial label).
2. Have your Technical Practice in front of you.
3. It is best if you are on site.

RETURNING PRODUCT FOR REPAIR

The following procedure is for equipment that needs repair:

1. Customer must contact Viking's Technical Support Department at 715-386-8666 to obtain a Return Authorization (RA) number. The customer **MUST** have a complete description of the problem, with all pertinent information regarding the defect, such as options set, conditions, symptoms, methods to duplicate problem, frequency of failure, etc.
2. Packing: Return equipment in original box or in proper packing so that damage will not occur while in transit. Static sensitive equipment such as a circuit board should be in an anti-static bag, sandwiched between foam and individually boxed. All equipment should be wrapped to avoid packing material lodging in or sticking to the equipment. Include ALL parts of the equipment. C.O.D. or freight collect shipments cannot be accepted. Ship cartons prepaid to: **Viking Electronics, 1531 Industrial Street, Hudson, WI 54016**
3. Return shipping address: Be sure to include your return shipping address inside the box. We cannot ship to a PO Box.
4. RA number on carton: In large printing, write the R.A. number on the outside of each carton being returned.

RETURNING PRODUCT FOR EXCHANGE

The following procedure is for equipment that has failed out-of-box (within 10 days of purchase):

1. Customer must contact Viking's Technical Support at 715-386-8666 to determine possible causes for the problem. The customer **MUST** be able to step through recommended tests for diagnosis.
2. If the Technical Support Product Specialist determines that the equipment is defective based on the customer's input and troubleshooting, a Return Authorization (R.A.) number will be issued. This number is valid for fourteen (14) calendar days from the date of issue.
3. After obtaining the R.A. number, return the approved equipment to your distributor, referencing the R.A. number. Your distributor will then replace the product over Viking using the same R.A. number.
4. **The distributor will NOT exchange this product without first obtaining the R.A. number from you. If you haven't followed the steps listed in 1, 2 and 3, be aware that you will have to pay a restocking charge.**

LIMITED WARRANTY

Viking warrants its products to be free from defects in the workmanship or materials, under normal use and service, for a period of one year from the date of purchase from any authorized Viking distributor or 18 months from the date manufactured, which ever is greater. If at any time during the warranty period, the product is deemed defective or malfunctions, return the product to Viking Electronics, Inc., 1531 Industrial Street, Hudson, WI., 54016. Customer must contact Viking's Technical Support Department at 715-386-8666 to obtain a Return Authorization (R.A.) number.

This warranty does not cover any damage to the product due to lightning, over voltage, under voltage, accident, misuse, abuse, negligence or any damage caused by use of the product by the purchaser or others. This warranty does not cover non-EWP products that have been exposed to wet or corrosive environments.

NO OTHER WARRANTIES. VIKING MAKES NO WARRANTIES RELATING TO ITS PRODUCTS OTHER THAN AS DESCRIBED ABOVE AND DISCLAIMS ANY EXPRESS OR IMPLIED WARRANTIES OR MERCHANTABILITY OR FITNESS FOR ANY PARTICULAR PURPOSE.

EXCLUSION OF CONSEQUENTIAL DAMAGES. VIKING SHALL NOT, UNDER ANY CIRCUMSTANCES, BE LIABLE TO PURCHASER, OR ANY OTHER PARTY, FOR CONSEQUENTIAL, INCIDENTAL, SPECIAL OR EXEMPLARY DAMAGES ARISING OUT OF OR RELATED TO THE SALE OR USE OF THE PRODUCT SOLD HEREUNDER.

EXCLUSIVE REMEDY AND LIMITATION OF LIABILITY. WHETHER IN AN ACTION BASED ON CONTRACT, TORT (INCLUDING NEGLIGENCE OR STRICT LIABILITY) OR ANY OTHER LEGAL THEORY, ANY LIABILITY OF VIKING SHALL BE LIMITED TO REPAIR OR REPLACEMENT OF THE PRODUCT, OR AT VIKING'S OPTION, REFUND OF THE PURCHASE PRICE AS THE EXCLUSIVE REMEDY AND ANY LIABILITY OF VIKING SHALL BE SO LIMITED.

IT IS EXPRESSLY UNDERSTOOD AND AGREED THAT EACH AND EVERY PROVISION OF THIS AGREEMENT WHICH PROVIDES FOR DISCLAIMER OF WARRANTIES, EXCLUSION OF CONSEQUENTIAL DAMAGES, AND EXCLUSIVE REMEDY AND LIMITATION OF LIABILITY, ARE SEVERABLE FROM ANY OTHER PROVISION AND EACH PROVISION IS A SEPARABLE AND INDEPENDENT ELEMENT OF RISK ALLOCATION AND IS INTENDED TO BE ENFORCED AS SUCH.

Product Support: (715) 386-8666

Due to the dynamic nature of the product design, the information contained in this document is subject to change without notice. Viking Electronics, and its affiliates and/or subsidiaries assume no responsibility for errors and omissions contained in this information. Revisions of this document or new editions of it may be issued to incorporate such changes.