

VIKING PRODUCT MANUAL

COMMUNICATION & SECURITY SOLUTIONS

**E-10A/EWP
E-20B/EWP
Speaker Phones**

July 23, 2014

Provide Convenient Handsfree Communication

The **E-10A** and **E-20B** are telephone line powered entry phones designed to provide two-way handsfree communication. Both function identically, but are available in two different housings to better suit the application. When the "Call" button is pressed, the **E-10A** or **E-20B** will come off-hook and will remain off-hook until a CPC signal is detected, the programmed time-out has elapsed, a busy signal is detected, or the call goes silent, making the unit automatically disconnect.

The **E-10A/20B** can be connected directly to a C.O. line or analog PABX/KSU station when programmed as a ringdown circuit, or used with a Viking Dialer. If a line or station is not available, Viking's **DLE-200B** ring down circuit can be used. One to four **E-10A/20B** speaker phones can share an existing phone line in a house or small business when used with a Viking **C-200**, **C-250** or **C-2000B** Entry Phone Controller.

The **E-10A-EWP** and **E-20A-EWP** shares all of the features of the **E-10A** and **E-20B** in addition to En-

**E-10A/E-10A-EWP****E-20B/E-20B-EWP**

hanced Weather Protection (EWP) for outdoor installations where the unit is exposed to precipitation or condensation. EWP products feature foam rubber gaskets and boots, sealed connections, gel-filled butt connectors, as well as urethane or thermal plastic potted circuit boards with internally sealed, field-adjustable trim pots and DIP switches for easy on-site programming. For more information, see **DOD# 859**.

Features

- Alternate action call button to place or cancel a call
- Intelligent call progress detection for automatic hang-up on CPC, silence, busy signal, or time out
- Telephone line powered
- Weather resistant features: mylar speaker, gaskets, internally sealed push button switch, UV stable exterior, enamel coated PCB
- **E-10A-EWP** and **E-20B-EWP** are designed to meet IP66 Ingress Protection Rating (see **DOD# 859**)
- Adjustable microphone and speaker volume
- Programmable maximum call length
- Selectable auto-answer feature allows remote monitoring
- Two way handsfree communication
- Programmable VOX (mic/speaker) switching speed

E-10A/E-10A-EWP Features:

- Vandal resistant, black powder painted, aluminum face plate with heavy duty 316 stainless steel call button and mounting gasket
- Flush mountable using included plastic rough-in box part # **259576**
- Surface mount with optional **VE-5x5 (DOD# 424)**

E-20B/E-20B-EWP Features:

- Light gray colored, impact resistant, U.V. stable, plastic chassis
- Surface mountable only

Applications

- Door or gate communication, business delivery entrances
- Use with a Viking **C-200** or **C-250** to control an **E-10A** or **E-20B** on a single line
- Use with a Viking **C-2000B** to control 1 to 4 **E-10A/E-20B**'s and door/gate control on a single phone line
- Provide unique front and back door chimes and paging when used with a Viking **SLP-1**, **SLP-4** and **C-2000B**
- Residential, commercial and industrial door security
- Use with a Viking **K-1900-5** or **K-1900-30** for automatic speed dialing on telephone lines or analog PABX/KSU station ports
- Use on any analog PABX station port with programmable ringdown capability

Specifications

Power: Telephone line powered (18 VDC/20mA minimum)
Dimensions: **E-10A:** Overall: 127mm x 127mm x 57.2mm (5" x 5" x 2.25"). Rough-in box: 102mm x 102mm x 57mm (4" x 4" x 2.25") **E-20B:** 140mm x 115mm x 38mm (5.5" x 4.5" x 1.5")
Shipping Weights: **E-10A:** 0.91 kg (2 lbs), **E-20B:** .75 kg (1.5 lbs)
Standard E-10A/E-20B Environment: -34° C to 65° C (-30° F to 150° F) with 5% to 95% non-condensing humidity
E-10A/E-20B-EWP Environment: -34° C to 65° C (-30° F to 150° F) with up to 100% condensing humidity
Speaker Volume: Approximately 70db maximum @ 1m
Ring Voltage: 25V AC RMS minimum
CPC Disconnect Time: 300ms minimum
REN: 0.8A
Connections: (2) gel-filled butt connectors

www.vikingelectronics.com
Information: (715) 386-8861

Installation

IMPORTANT: Electronic devices are susceptible to lightning and power station electrical surges from both the AC outlet and the telephone line. It is recommended that a surge protector be installed to protect against such surges.

A. Mounting the E-10A and E-10A-EWP

The **E-10A** and **E-10A-EWP** are designed to be flush mounted to the included 4" x 4" x 2" deep plastic rough in box or surface mounted using an optional Viking model **VE-5x5**. **Note:** The **E-10A** and **E-10A-EWP** will NOT mount to a standard double gang box. The plastic rough in box (part # 259576) may be purchased separately. Go to www.vikingelectronics.com and click on "Spare Parts".

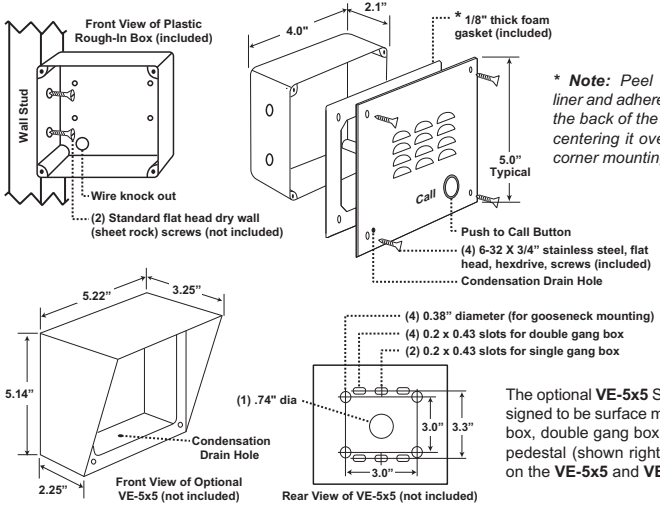

*** Note:** Peel off paper liner and adhere gasket to the back of the faceplate, centering it over the four corner mounting holes.

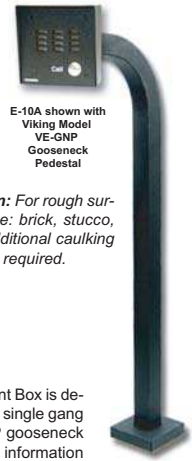

Caution: For rough surfaces (ie: brick, stucco, etc.) additional caulking may be required.

The optional **VE-5x5** Surface Mount Box is designed to be surface mounted to a single gang box, double gang box or **VE-GNP** gooseneck pedestal (shown right). For more information on the **VE-5x5** and **VE-GNP**, see **DOD# 424**.

B. Mounting the E-20B and E-20B-EWP

The **E-20B** and **E-20B-EWP** are designed to be surface mounted to a single gang box (not included), a standard 4" x 4" electrical junction box (not included), or directly to a wall or flat sided post. **Caution:** For rough surfaces (ie: brick, stucco, etc.) additional caulking may be required.

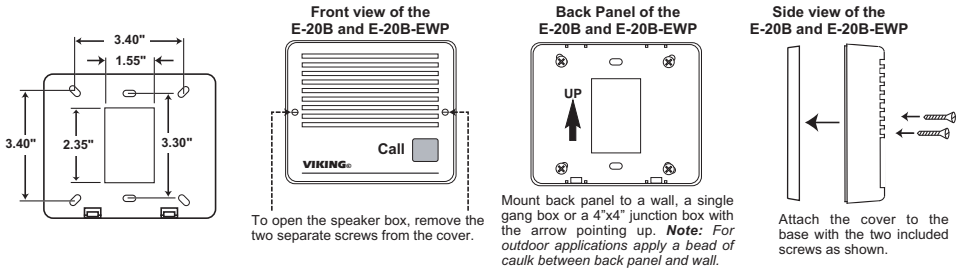

C. Wiring

***** Note:** When wires are routed from above, a "drip loop" is recommended to keep water away from the circuit board.

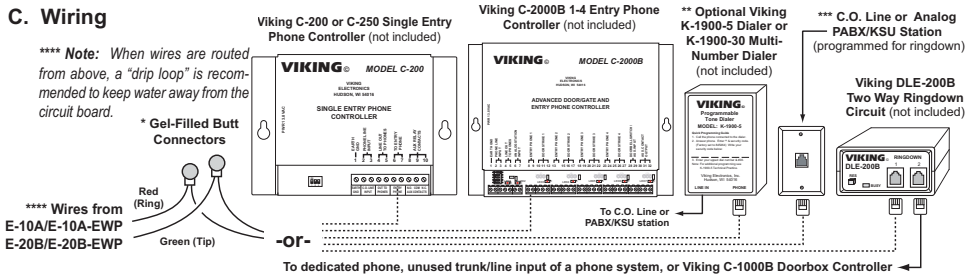

*** Note:** The gel-filled (water-tight) butt connectors are designed for insulation displacement on 19-26 gauge wire with a maximum insulation of 0.082 inches. Cut off stripped wire ends before terminating.

**** Note:** Talk battery must be a minimum of 28V DC when using the speaker phone with a Viking **K-1900-5 Dialer (DOD# 317)** or **K-1900-30 Multi-Number Dialer (DOD# 300)**.

***** Note:** When installing a line powered phone on a low voltage and/or low loop current phone system extension, a Viking **TBB-1B Talk Battery Booster** may be required, see **DOD# 632**.

Programming

A. Adjusting the Speaker Volume

The **SPKR VOL** pot can be adjusted to increase or decrease the speaker volume to the level desired as shown.

B. Adjusting the Microphone Volume

In certain noisy locations (background traffic, machinery or wind), the microphone volume may need to be decreased. A symptom of this is one-way talk path, in which the distant party cannot be heard over the speaker. A **MIC VOL** pot is provided for increasing or decreasing the microphone volume. **Note:** *If the microphone volume is set too high or too low, one-way talk path may occur.*

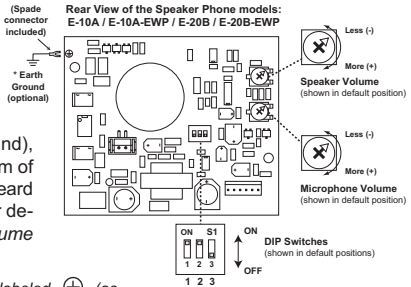

* **Note:** To increase surge protection, loosen the PCB mounting screw labeled  (as shown) and fasten a wire with spade terminal (included) from the mounting screw to Earth Ground (grounding rod, water pipe, etc.)

C. DIP Switch Programming

1. Auto Answer Feature (DIP Switch 1)

DIP switch 1 is for turning the Auto Answer feature ON and OFF. The **E-10A/E-20B** is factory set to auto answer when an inbound call is detected.

2. Dial Tone Detection (DIP Switch 2)

With DIP switch 2 in the ON position, if the **E-10A/E-20B** detects more than 5 seconds of continued dial tone, the unit will automatically disconnect. If the **E-10A/E-20B** is installed on a continuously noisy line, it may detect the noise as dial tone and automatically disconnect. If this happens, turn the dial tone detection (DIP switch 2) OFF.

3. Programming Mode (DIP Switch 3)

With DIP switch 3 in the OFF position, the **E-10A/E-20B** is in the "Normal Operation Mode" (factory setting). By placing DIP switch 3 in the ON position, the **E-10A/E-20B's** programming mode is enabled. The programming mode is used for adjusting the Call Length Time Out, Silence Time for automatic disconnect and the Talk/Listen delay (VOX switching speed). These features are set from the factory and normally do not need adjustment. If adjustment is necessary, see **Programming** sections **D - I**.

Switch	Position	Description
1	ON	Auto answer ON*
1	OFF	Auto answer OFF
2	ON	Dial tone detection ON*
2	OFF	Dial tone detection OFF
3	ON	Programming mode
3	OFF	Normal operation mode*

D. Accessing the Programming Mode

The **E-10A/E-20B** can be programmed from any Touch Tone phone using a telephone line, Viking model **C-200** or **C-2000A** Entry Phone Controller, analog PABX/KSU station or a Viking model **DLE-200B** Line Simulator.

Step 1.	Move DIP switch 1 to the ON position (sets unit to answer incoming calls - see section C).
Step 2.	Move DIP switch 3 to ON (incoming calls automatically enter the programming mode - see section C).
Step 3.	From a Touch Tone phone call the line attached to the E-10A/E-20B .
Step 4.	When the E-10A/E-20B answers, 2 beeps will be heard and you will automatically enter the programming mode.
Step 5.	When finished programming, enter "0000" to exit programming and move DIP switch 3 back to OFF (see section C).

E. Quick Programming Features

Description	Select Feature	Wait for Beep(s)	Enter Time Value	Wait for 2 Beeps
Call length time out (1-9 minutes), 10 = disabled (factory set to 1111 = 5 minutes)	0	beep	111...	beep beep
Silence time out for disconnect (10-90 seconds), 10 = disabled (factory set to 1111 = 40 secs)	00	beep	111...	beep beep
Talk/listen delay (VOX switching speed) 0.1 - 0.9 seconds (factory set to 111 = 0.3 secs)	000	beep	111...	beep beep
Forced hang-up command (used to exit programming and hang up)	0000	3 beeps	111...	beep beep

F. Programming Beeps

If a valid "Feature" is entered, a single beep will be heard. If an invalid "Feature" (five or more zeros) is entered, 3 beeps will be heard and the **E-10A/E-20B** will hang up. If a valid "Time" is entered 2 beeps will be heard. If an invalid "Time" is entered, 3 beeps will be heard and you will have 20 seconds to enter the next valid "Feature".

G. Call Length Time Out

This feature selects the maximum length of time that calls can be connected. Programmable in increments of 1 minute up to a maximum of 9 minutes. Programming nothing in the time value location will disable the call length time out. With the call length disabled, the **E-10A/E-20B** phone must rely on CPC, busy, silence or return dial tone to hang-up. Use the chart at the right. * **Note:** *The factory default is 5 minutes.*

See table below 

Time Value	Call Length Time Out	Silence Time Out	Talk/Listen Delay
1	1 min	10 sec	.1 sec
11	2 min	20 sec	.2 sec
111	3 min	30 sec	.3 sec*
1111	4 min	40 sec*	.4 sec
11111	5 min*	50 sec	.5 sec
111111	6 min	60 sec	.6 sec
1111111	7 min	70 sec	.7 sec
11111111	8 min	80 sec	.8 sec
111111111	9 min	90 sec	.9 sec
10 or more	Disabled	Disabled	Error

H. Silence Time Out

This feature selects the length of time that calls will remain connected without voice activity. Programmable in increments of 10 seconds up to a maximum of 90 seconds. To disable the silence time out, program nothing in the time value location. Use the chart on page 3. ***Note: The factory default is 40 seconds.**

I. Talk/Listen Delay (VOX Switching Speed)

This feature selects switching time between talk and listen modes (VOX switching time). Use the chart on page 3. ***Note: The factory default is .3 seconds.**

Operation

When the push button is pressed, the **E-10A/E-20B** phone goes off-hook, much like a standard speaker phone. In the event that the line is busy, the **E-10A/E-20B** will hang up. The **E-10A/E-20B** will also automatically hang up on CPC, silence, busy signal, return to dial tone or time out. If programmed to auto-answer (DIP switch 1 ON), the **E-10A/E-20B** will also answer any incoming call.

Warranty

IF YOU HAVE A PROBLEM WITH A VIKING PRODUCT, CONTACT: VIKING TECHNICAL SUPPORT AT (715) 386-8666

Our Technical Support Department is available for assistance Monday 8am - 4pm and Tuesday through Friday 8am - 5pm central time. So that we can give you better service, before you call please:

1. Know the model number, the serial number and what software version you have (see serial label).
2. Have your Technical Practice in front of you.
3. It is best if you are on site.

RETURNING PRODUCT FOR REPAIR

The following procedure is for equipment that needs repair:

1. Customer must contact Viking's Technical Support Department at 715-386-8666 to obtain a Return Authorization (RA) number. The customer MUST have a complete description of the problem, with all pertinent information regarding the defect, such as options set, conditions, symptoms, methods to duplicate problem, frequency of failure, etc.
2. Packing: Return equipment in original box or in proper packing so that damage will not occur while in transit. Static sensitive equipment such as a circuit board should be in an anti-static bag, sandwiched between foam and individually boxed. All equipment should be wrapped to avoid packing material lodging in or sticking to the equipment. Include ALL parts of the equipment. C.O.D. or freight collect shipments cannot be accepted. Ship cartons prepaid to: Viking Electronics, 1531 Industrial Street, Hudson, WI 54016
3. Return shipping address: Be sure to include your return shipping address inside the box. We cannot ship to a PO Box.
4. RA number on carton: In large printing, write the R.A. number on the outside of each carton being returned.

RETURNING PRODUCT FOR EXCHANGE

The following procedure is for equipment that has failed out-of-box (within 10 days of purchase):

1. Customer must contact Viking's Technical Support at 715-386-8666 to determine possible causes for the problem. The customer MUST be able to step through recommended tests for diagnosis.
2. If the Technical Support Product Specialist determines that the equipment is defective based on the customer's input and troubleshooting, a Return Authorization (R.A.) number will be issued. This number is valid for fourteen (14) calendar days from the date of issue.
3. After obtaining the R.A. number, return the approved equipment to your distributor, referencing the R.A. number. Your distributor will then replace the Viking product using the same R.A. number.
4. The distributor will NOT exchange this product without first obtaining the R.A. number from you. If you haven't followed the steps listed in 1, 2 and 3, be aware that you will have to pay a restocking charge.

LIMITED WARRANTY

Viking warrants its products to be free from defects in the workmanship or materials, under normal use and service, for a period of one year from the date of purchase from any authorized Viking distributor or 18 months from the date manufactured, whichever ever is greater. If at any time during the warranty period, the product is deemed defective or malfunctions, return the product to Viking Electronics, Inc., 1531 Industrial Street, Hudson, WI., 54016. Customer must contact Viking's Technical Support Department at 715-386-8666 to obtain a Return Authorization (R.A.) number.

This warranty does not cover any damage to the product due to lightning, over voltage, under voltage, accident, misuse, abuse, negligence or any damage caused by use of the product by the purchaser or others. This warranty does not cover non-EWP products that have been exposed to wet or corrosive environments.

NO OTHER WARRANTIES: VIKING MAKES NO WARRANTIES RELATING TO ITS PRODUCTS OTHER THAN AS DESCRIBED ABOVE AND DISCLAIMS ANY EXPRESS OR IMPLIED WARRANTIES OR MERCHANTABILITY OR FITNESS FOR ANY PARTICULAR PURPOSE.

EXCLUSION OF CONSEQUENTIAL DAMAGES: VIKING SHALL NOT, UNDER ANY CIRCUMSTANCES, BE LIABLE TO PURCHASER, OR ANY OTHER PARTY, FOR CONSEQUENTIAL, INCIDENTAL, SPECIAL OR EXEMPLARY DAMAGES ARISING OUT OF OR RELATED TO THE SALE OR USE OF THE PRODUCT SOLD HEREUNDER.

EXCLUSIVE REMEDY AND LIMITATION OF LIABILITY: WHETHER IN AN ACTION BASED ON CONTRACT, TORT (INCLUDING NEGLIGENCE OR STRICT LIABILITY) OR ANY OTHER LEGAL THEORY, ANY LIABILITY OF VIKING SHALL BE LIMITED TO REPAIR OR REPLACEMENT OF THE PRODUCT, OR AT VIKING'S OPTION, REFUND OF THE PURCHASE PRICE AS THE EXCLUSIVE REMEDY AND ANY LIABILITY OF VIKING SHALL BE SO LIMITED.

IT IS EXPRESSLY UNDERSTOOD AND AGREED THAT EACH AND EVERY PROVISION OF THIS AGREEMENT WHICH PROVIDES FOR DISCLAIMER OF WARRANTIES, EXCLUSION OF CONSEQUENTIAL DAMAGES, AND EXCLUSIVE REMEDY AND LIMITATION OF LIABILITY, ARE SEVERABLE FROM ANY OTHER PROVISION AND EACH PROVISION IS A SEPARABLE AND INDEPENDENT ELEMENT OF RISK ALLOCATION AND IS INTENDED TO BE ENFORCED AS SUCH.

FCC REQUIREMENTS

This equipment complies with Part 68 of the FCC rules and the requirements adopted by the ACTA. On the side of this equipment is a label that contains, among other information, a product identifier in the format USAAECQ##TXXXX. If requested, this number must be provided to the telephone company.

The REN is used to determine the number of devices that may be connected to a telephone line. Excessive REN's on a telephone line may result in the devices not ringing in response to an incoming call. In most but not all areas, the sum of the REN's should not exceed five (5.0). To be certain of the number of devices that may be connected to a line, as determined by the total REN's, contact the local telephone company. For products approved after July 23, 2001, the REN for this product is part of the product identifier that has the format USAAECQ##TXXXX. The digits represented by ## are the REN without a decimal point (e.g., 03 is a REN of 0.3). For earlier products, the REN is separately shown on the label.

The plug used to connect this equipment to the premises wiring and telephone network must comply with the applicable FCC Part 68 rules and requirements adopted by the ACTA. If your home has specially wired alarm equipment connected to the telephone line, ensure the installation of this E-10A/E-20B does not disable your alarm equipment. If you have questions about what will disable alarm equipment, consult your telephone company or a qualified installer.

If the E-10A/E-20B causes harm to the telephone network, the telephone company will notify you in advance that temporary discontinuance of service may be required. But if advance notice isn't practical, the telephone company will notify the customer as soon as possible. Also, you will be advised of your right to file a complaint with the FCC if you believe it is necessary.

The telephone company may make changes in its facilities, equipment, operations, or procedures that could affect the operation of the equipment. If this happens, the telephone company will provide advance notice in order for you to make the necessary modifications to maintain uninterrupted service.

If trouble is experienced with the E-10A/E-20B, for repair or warranty information, please contact:

Viking Electronics, Inc., 1531 Industrial Street, Hudson, WI 54016 (715) 386-8666

If the equipment is causing harm to the telephone network, the telephone company may require that you disconnect the equipment until the problem is resolved.

Connection to Party Line Service is subject to State Tariffs. Contact the state public utility commission, public service commission or corporation commission for information.

WHEN PROGRAMMING EMERGENCY NUMBERS AND (OR) MAKING TEST CALLS TO EMERGENCY NUMBERS:

Remain on the line and briefly explain to the dispatcher the reason for the call. Perform such activities in the off-peak hours, such as early morning or late evenings.

It is recommended that the customer install an AC surge arrester in the AC outlet to which this device is connected. This is to avoid damaging the equipment caused by local lightning strikes and other electrical surges.

PART 15 LIMITATIONS

This equipment has been tested and found to comply with the limits for a Class A digital device, pursuant to Part 15 of the FCC Rules. These limits are designed to provide reasonable protection against harmful interference when the equipment is operated in a commercial environment. This equipment generates, uses, and can radiate radio frequency energy and, if not installed and used in accordance with the instruction manual, may cause harmful interference to radio communications. Operation of this equipment in a residential area is likely to cause harmful interference in which case the user will be required to correct the interference at his own expense.

Product Support: (715) 386-8666

Due to the dynamic nature of the product design, the information contained in this document is subject to change without notice. Viking Electronics, and its affiliates and/or subsidiaries assume no responsibility for errors and omissions contained in this information. Revisions of this document or new editions of it may be issued to incorporate such changes.