

Summary

USB-I2C is a single chip USB to synchronous serial I2C slave interface. It greatly simplifies the connection of personal computer to a microcontroller capable of communicating in I2C master mode. In addition to the standard 2 I2C control lines, 11 additional Virtual I/O lines have custom-defined functionality.

USB-I2C uses the Human Interface Device (HID) USB profile. It does not require USB driver installation, and so is compatible with present and future Windows, Linux and Mac operating systems.

USB-I2C is firmware for the PIC18LF2455 and PIC18F14K50 microcontrollers. It requires only a few discrete components and is available 28-pin DIL and 20-pin SSOP packages.

For I2C master applications (to control I2C slave devices), our expandIO-USB product is more suitable.

Features

- Suitable for connection to I2C master devices
- Single chip solution
- True HID plug and play - No drivers required
- USB 2.0 compatible
- Achievable data transfer rates up to 600K baud
- Max I2C clock rate 1MHz
- 32-bit serial number
- 128-byte FIFO receive buffer
- 128-byte FIFO transmit buffer
- Operating voltage 1.8V – 5V
- 11 auxiliary I/O pins, configurable as digital I/O, 10-bit A-to-D, USB status
- VID, PID, product descriptor and I/O configuration may be specified at program time or at runtime
- PIC18F14K50-based DIL, SSOP packages
- PIC18LF2455-based DIL, SIOC packages

Mechanical Specifications

VIO0/Vpp	1	28	PGD	Vdd	1	20	Vss
n.c.	2	27	PGC	OSC1	2	19	D+/PGD
n.c.	3	26	n.c.	OSC2	3	18	D-/PGC
n.c.	4	25	n.c.	VIO0/Vpp	4	17	Vusb
VIO1	5	24	VIO10	VIO1	5	16	VIO10
VIO2	6	23	VIO9	VIO2	6	15	VIO9
n.c.	7	22	SCL	VIO3	7	14	VIO8
Vss	8	21	SDA	n.c.	8	13	SDA
OSC1	9	20	Vdd	n.c.	9	12	VIO5
OSC2	10	19	Vss	VIO4	10	11	SCL
VIO3	11	18	n.c.				
VIO4	12	17	VIO8				
VIO5	13	16	D+				
Vusb	14	15	D-				

Fig 1 - USB-I2C pinout
Pins marked n.c. should be grounded

Applications

- USB I2C slave for connection to I2C host devices
- USB data transfer for consumer products
- USB industrial control

Firmware Factory USB Product Family

- USB-232 asynchronous serial interface
- TEAleaf-USB security and authentication dongle
- expandIO-USB I/O expander
- USB-I2C synchronous serial interface
- USB-I2C synchronous serial interface
- USB-TakeOff managed power take-off, wakeup and charge controller
- USB-DAQ data logger
- USB-FileSys USB embedded file system

Table 1. Electrical Specifications

Operating voltage (20 pin / 28 pin)	1.8V/2.7V–5.5V
Typical/max supply current, Vdd = 5.0	10mA / 21mA
Operating Temperature	-40°C to +85°C
Refer to base microcontroller data sheet for further information	



Firmware Factory Ltd
2 Marshall St, 3rd Floor
London W1F 9BB, UK
sales@firmwarefactory.com
support@firmwarefactory.com

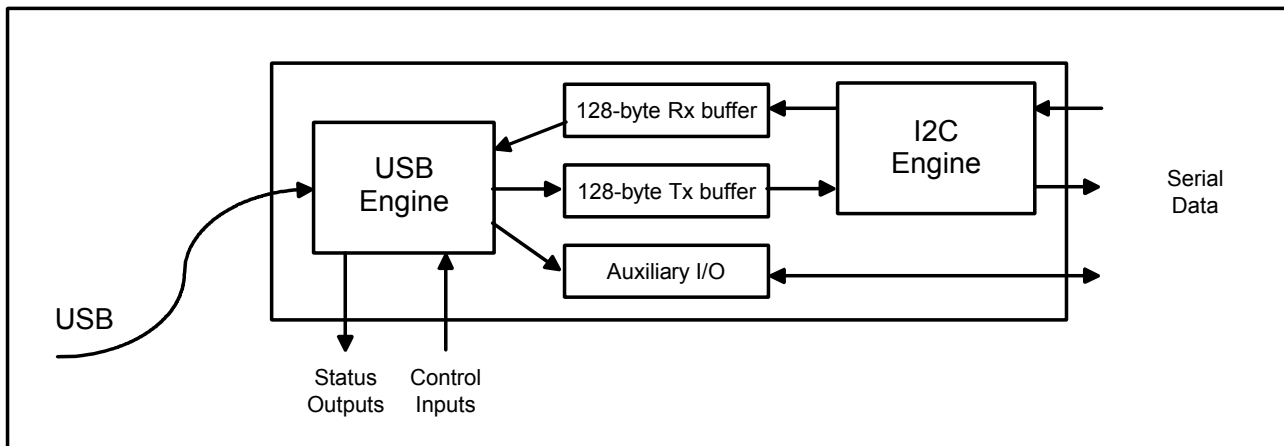

Basic Operation

To the electronic system ('device'), USB-I2C looks like a I2C serial slave device. To the PC ('host'), it looks like a Human Interface Device (HID) with which it may exchange information using simple commands. When the data is sent to USB-I2C from the device using its write address, the data is buffered and sent to the PC. When it is addressed by the device using its read address, any data sent from the PC is output to the device.

Using the HID USB profile means that no driver installation is required and immediate compatibility is assured on Windows, Linux and OS systems. Additionally, software can find the device automatically without needing to know which virtual COM port it is occupying.

Pin Functions

The pin functions are shown in table 2. The function of the virtual I/O pins is reconfigurable, so their default settings are also shown. Note that the output pins are in a tri-state condition until ~20µs after power-on.

Table 2. Device Pinout			
DIL	SSOP	Name	Description
1	4	VIO0 Vpp	Virtual I/O / *Reset# (in) TEAclipper Vpp
5	5	VIO1	Virtual I/O / *Tx Ind (out)
6	6	VIO2	Virtual I/O / *Rx Ind (out)
11	7	VIO3	Virtual I/O / *Tx/Rx Ind (out)
12	10	VIO4	Virtual I/O / *All-Systems-Go# (out)
22	11	SCL	Slave serial data clock input
13	12	VIO5	Virtual I/O / *Suspend# (out)
21	13	SDA	Slave serial data input / output
17	14	VIO8	Virtual I/O / *Tx Buffer Empty (out)
23	15	VIO9	Virtual I/O / *Send (int)
24	16	VIO10	Virtual I/O / *Rx Buffer Not Full (out)
14	17	Vusb	USB supply filter
15	18	D-	USB data -
27		PGC	TEAclipper PGC
16	19	D+	USB data+
28		PGD	TEAclipper PGD
8,19	20	Vss	Power ground reference
20	1	Vdd	Power positive input
9	3	OSC1	Oscillator output
10	2	OSC2	Oscillator input
* = default configuration # = active low			

The pin functions are described in detail below.

Vss, Vdd, Vusb

Vss is the power supply ground reference. Vdd should be connected to a regulated supply, for example the USB bus power. Vusb should be connected, via a 470nF capacitor, to Vss. See for example C8 in figure 2.

OSC1, OSC2

OSC1 and OSC2 should be connected to a 12MHz parallel cut crystal circuit with 22pF capacitors. It may be replaced with a 12MHz resonator with 0.25% total tolerance.

SCL, SCK

I2C serial data I/O. Data is input or output on SDA according to the read/write address. The SCL input provides synchronization according to usual I2C standards. The I2C default read/write addresses are 0x27 and 0x26 respectively; these values may be changed using the *HIDconfig.exe* application.

Vpp, PGC, PCD

TEAclipper programming pins. Refer to the Delivery and Programming section for details. Note that the Vpp pin may be subject to voltages as high as 12V during programming.

VIO pins

The VIO pin functions can be reconfigured as detailed in the customization section. The default functions are shown in table 2. The pins can be configured as follows.

No Function

The pin is a digital input that has no effect. To minimize power consumption, it should be biased high or low. This setting is available on all VIOs.

Reset

The pin is an active low reset input. Resetting the device effectively implements the soft detach function. This setting is available on VIO0 only.

USB Power Sense

If the device is capable of operating while not plugged into a USB port, a USB Power Sense input should be provided. This pin should indicate that a voltage is detected on the V+ pin of the USB connector. It is used to reduce power consumption by entering into a sleep mode when the USB is not present, and also to ensure that the USB engine correctly initializes when the device is plugged in. The I2C port is not operational during sleep. This setting must be on VIO9.

Self Power Sense

If the device is capable of operating while not plugged into a USB port, a Self Power Sense input may be provided. This pin should indicate when the device is not drawing power from the USB bus and can help the PC manage its power budget. This setting is available on any VIO pin.

Tx Indication

Output for connecting to a transmit indication LED. It turns on for approximately 100ms when data has been transmitted to the host. This setting is available on any VIO pin except VIO0.

Rx Indication

Output for connecting to a receive indication LED. It turns on for approximately 100ms when data has been received from the host. This setting is available on any VIO pin except VIO0.

Tx / Rx Indication

Output for connecting to a transmit / receive indication LED. It turns on for approximately 100ms when data

has been transmitted to or received from the host. This setting is available on any VIO pin except VIO0.

Configured Indication

Output that indicates when the USB interface has completed configuration and the host has indicated that the device may draw its full power setting. Prior to configuration completing, the device should draw no more than 100mA from the bus. Note that the configured indication continues to stay high when in suspend mode, even though the device must consume no more than 100µA during suspend. This setting is available on any VIO pin except VIO0. Refer to table 3.

Suspend Indication

Output that indicates when the host is entering a sleep state (active low). In this state, the device should draw no more than 100µA from the bus, excluding the consumption of the USB-I2C chip. This setting is available on any VIO pin except VIO0. Refer to table 3.

Host Ready Indication

Output that indicates when an application has signaled that it has located the device, and it is available for communication. This setting is available on any VIO pin except VIO0. Refer to table 3.

Low Power Indication

Output which is high when the device must draw no more than 100mA from the bus, rather than the maximum power it has been configured for. This setting is available on any VIO pin except VIO0. Refer table 3.

All-Systems-Go Indication

Output that indicates when the USB-I2C is configured and not suspended. This setting is available on any VIO pin except VIO0. Refer to table 3.

Pin	Initial-izing	Initialized		Host App Running		Host Sleep
		LP†	HP‡	LP†	HP‡	
Configured	0	1	1	1	1	1
Suspend#	1	1	1	1	1	0
Low Pwr	1	1	0	1	0	1
All Sys Go#	1	0	0	0	0	1
Host Rdy	0	0	0	1	1	0

† LP = Plugged into unpowered hub
‡ HP = Plugged direct into host or powered hub

Rx Buffer Not Full

Buffer Not Full is an output, indicating that serial data may be sent to the device for transmission to the PC. It will transition to inactive when only 16 bytes of buffer space remain. It will transition to active when 32 or more bytes of buffer space remain. Data sent while buffer space remains will be accepted, even if Buffer Not Full is inactive. If data is sent after the buffer is full, it is discarded; it does not overwrite data already in the buffer.

This setting is available on any VIO pin except VIO0.

Tx Buffer Empty

Output that indicates that there is no buffered data from the PC waiting to be output through the I2C port. This pin will change to low as soon as data is added to the buffer, and to high as soon as the last byte starts to be output from the serial port. This setting is available on any VIO pin except VIO0.

Send

Send is an input which controls when data is transmitted to the host. This pin is normally held in the active state. In the active state, data is buffered until 63 bytes have arrived or a stop condition occurs.

If the send pin is inactive, data will be buffered and not transmitted to the host. If the pin transitions to the active state, an interrupt will be generated and the data will be sent to the host immediately. Send must be on VIO9.

Digital Input

Digital Input is a general purpose input. Its state can be read using the Get Pin command. This setting is available on any VIO pin.

Digital Output

Digital Output is a general purpose output. Its state can be set using the Set Pin command and read using the Get Pin command. On power-up and reset, it will initialize to the inactive state. This setting is available on any VIO pin except VIO0.

Interrupt

Interrupt is a general purpose input whose state can be read using the Get Pin command. When it transitions from the inactive state to the active state, it will generate an Interrupt response. Interrupts must be on VIO9. If this pin is connected to a switch it should be de-bounced to avoid generating multiple Interrupt responses.

Analog Input

Analog Input is a general purpose analog input whose voltage can be read using the Get Analog command. This setting is available on VIO1 only on 28-pin devices and VIO3 only on 20-pin devices.

Device Fuses

Fuses are non-volatile settings you may select to customize your device. For information on how to modify them, refer to the device configuration section.

Write Lock

Once the write lock bit is set, all commands which change the device strings and fuses will have no effect. Unless otherwise configured, the default is unlocked.

Max Bus Power

The maximum power required by your product is specified by the Max Bus Power fuse. It allows the host to balance its power budget, and is subject to certain limitations:

1. No device may consume more than its Max Bus Power specification at any time, and never more than 500mA.
2. No device may consume more than 100mA unless the Low Power output pin indicates it permitted to do so.
3. If the Suspend mode output pin go high, (or the All-Systems-Go / Host Ready outputs go low), the host is in sleep mode and the product may draw no more than 100µA from the bus (not including the power consumed by the USB-I2C chip).

Unless otherwise configured, the default value is 100mA.

Power Source

The device can be self powered only, USB bus powered only, or both. If both, the Self Power sense input pin should be used to indicate when the device is using its own power and not consuming bus power. This information will be communicated to the host.

Unless otherwise configured, the default source is USB only.

Device Address

Specifies the I2C write address. This should be an even number; the read address will be one higher. The default is 0x26 (write) / 0x27 (read)

Null Tx Char

Specifies the character which should be sent if the host microcontroller attempts to read a character when the Tx buffer is empty. The default value is 0xFF.

Once the host has addressed the USB-I2C, if the Tx buffer is empty, a null character will be loaded into the I2C port for transmission. It is not possible to remove it from the transmission stream, even if data arrives in the Tx buffer prior to the I2C port clocking the null character out.

Acknowledge

HID buffers discard old data if they get full. If your host application might be too busy to process data immediately, you may specify that all data transmitted to the host must be acknowledged as read using an acknowledge command before further data is sent. Unless otherwise configured, this is disabled by default.

Likewise, the host may request that USB-I2C acknowledges every packed as having been processed. In this case it acknowledges automatically. In this case, the acknowledge is sent when the data has been safely buffered, not when it has completed outputting from TxD.

The Acknowledge operation is between the USB-I2C chip and the PC; its operation is transparent to the I2C host.

Custom VID / PID

Personalized Vendor and Product IDs are not required. However, you may customize them if you wish. Unless otherwise configured, the default Vendor ID is 0x0B40, and the default Product ID 0x012C for the 28-pin device and 0x011D for the 20-pin device.

Device Strings

Device strings are non-volatile Unicode strings stored by the USB-I2C and which may be read by the host PC and all its applications. For information on how to modify them, refer to the customization section.

Product Name

The manufacturer name is a Unicode string of up to 61 characters plus zero terminator. The host application can read this data using a Get Feature request for string 1. The host PC commonly displays this string while it is installing the default HID driver when it is first inserted. Unless otherwise configured, the default value is "USB-I2C".

Manufacturer Name

The manufacturer name is a Unicode string of up to 61 characters plus zero terminator. The host application can read this data using a Get Feature request for string 2. The host PC commonly displays this string while it is installing the default HID driver when it is first inserted. Unless otherwise configured, the default value is "Firmware Factory Ltd".

Serial Number

The Serial Number data is a Unicode string of up to 61 characters plus zero terminator. The host application can read this data using a Get Feature request for string 3. The Serial Number is a unique string which you can use to differentiate one physical device from other devices with the same USB-I2C Vendor ID / Product ID / Product GUID combination. Unless otherwise configured, the default value is a unique value.

Product GUID

The product GUID is a Unicode string of up to 61 characters plus zero terminator. The host application can read this data using a Get Feature request for string 4. The product GUID is a string which you can use to differentiate a product from other devices with the USB-I2C Vendor ID / Product ID combination. It should be the same for all products of the same type. Unless otherwise configured, the default value is "No GUID".

Config (EEPROM) String

The configuration data is a Unicode string of up to 61 characters plus zero terminator (i.e. 122 bytes). You can use it as you wish to store configuration data on the product which the host software can access. The host application can read this data using a Get Feature request for string 5. Unless otherwise configured, the default value is "No Config".

Application Circuits

The following circuits are typical implementations of the USB-I2C. Suggested component values are shown in table 4. For initial evaluation, the Bus Powered Device circuit is recommended.

Label	Component
R1-R2, R1x	22k resistor
R4, R5, R30, R50	4k7 resistor

Table 4. Suggested component values	
Label	Component
R6	1k resistor
R2x	470Ω resistor
R40	100k resistor
T1, T2	P-channel Mosfet, e.g. NDS352P
D1, D2	Low Vf switching diode
LED1x	Light emitting diode
C1	1μF capacitor
C2, C3	22pF capacitor
C4, C6-C7	100nF capacitor
C8	470nF capacitor
PB1x	Pushbutton or switch
X1	12MHz parallel cut crystal

Bus Powered Device

Figure 2 is the suggested circuit when initially evaluating USB-I2C.

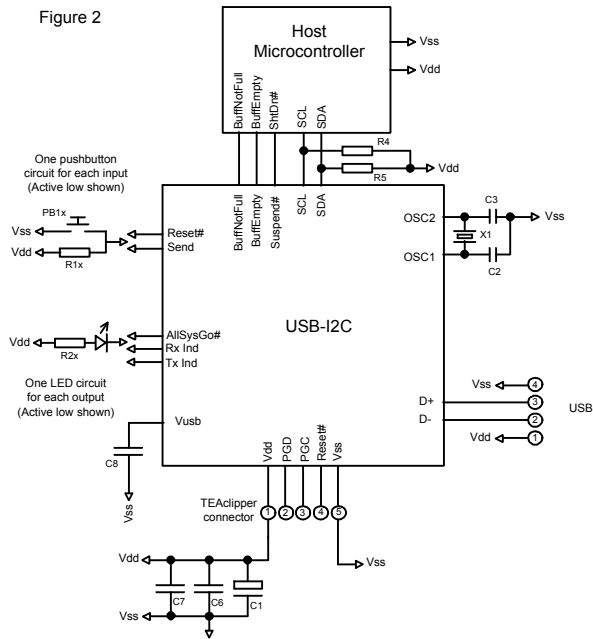

The microcontroller sends and receives data via its I2C pins *SCL* and *SDA*. These bus lines require 4k7 pull-ups. The *Rx Buff Not Full* and *Tx Buffer Full* can be monitored if required for flow control. When *Rx Buffer Not Full* is low, no data should be sent to the USB-SPI. If *Tx Buff Empty* is high and the microcontroller reads data from USB-SPI, then *Null Tx Char* will be read. When it *ShtDn#* low, the microcontroller and the rest of the circuit should go into a sleep state.

The pushbutton circuits allow you to apply logic 1 or logic 0 to input pins. The LED circuits allow you to view the state of output pins. As shown they are active low. For commercial applications these circuits need only be provided if required.

Oscillator X1/C2/C3 may be replaced by a low-cost resonator, provided its frequency tolerance is greater than 0.25%. C1 and C6 should be placed close to the USB connector. C7 should be placed near the Vss and Vdd pins of the USB-I2C and is required only if it would be some distance from C6. C8 is a filter capacitor for an internal regulator and is required.

The TEAcclipper connector is for in-circuit programming of devices where the firmware has been purchased from HexWax. It is recommended to allow firmware updates, even if the firmware is initially supplied pre-programmed.

Self Powered Device

A self-powered device does not need to draw power from the USB bus. In this case, the USB-I2C can be put into sleep mode when USB power is not available. The sub-circuit required to do this is shown in figure 3. If the device is self-powered, it is not necessary to enter the sleep state if the Suspend indicate is active.

Figure 3

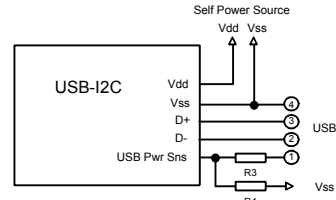

Both-powered Powered Device

If both self-powered and bus powered configurations are possible, a circuit must be provided to switch over power to USB power. An example sub-circuit is given in figure 4, where it is assumed that USB power is used when it is available. To give self-power priority, place T2 so that it switches the USB power line instead. D1 and D2 ensure that the two power lines are not in contention. If the self-power source is 3.3V, the diodes will be sufficient and T2 will not be required at all.

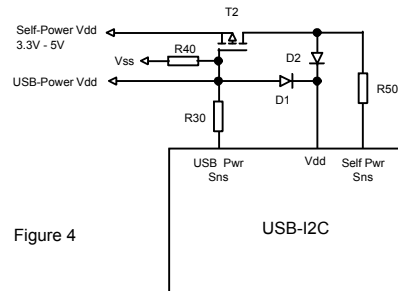

Figure 4

Power Take-Off

A device should only draw current from the USB line once USB configuration is complete and the host PC is not in sleep mode. The *AllSysGo#* output (active low) can provide such a switch using the sub-circuit shown in figure 5. C4 / R6 provide a slow switch-on to prevent inrush current exceeding USB power limitations. 1μF and 100nF smoothing capacitors are recommended on both self and USB power lines. The Low Pwr output should be monitored if the device can draw more than 100mA.

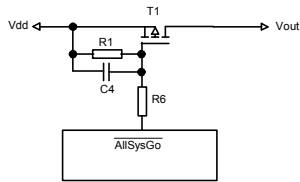

Figure 5

Power considerations

Initially, the device will request the full power it is configured for. If it is not granted this power level within three seconds, it performs a soft detach and requests a maximum of 100mA. This allows devices to operate in a low power mode when connected to an unpowered hub. This reduced power mode is indicated by the Low Pwr Indication pin.

If the device is electromagnetically noisy, a ferrite bead is recommended on the USB Vdd supply in order to suppress any transmission of noise to the rest of the USB network. 100nF smoothing capacitors should be provided on all independently switched power rails to avoid momentary brown-out conditions.

When designing self powered circuits, ensure power can never be fed into the Vdd USB line. Design note AN1149 from Microchip Technology, in the development kit, discusses designs for recharging batteries using USB bus power.

USB Connectors

Common USB connector and cable configurations are shown in figure 6 and table 5. The shield on the connector should be left unconnected. The ID pin on the mini connector permits the distinction of A and B plugs. The micro connector pin-out is the same as the mini connector.

Figure 6 Common USB pin-outs for male connectors

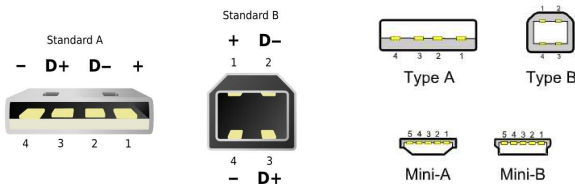

Table 5. USB Connection Key

Pin	Std	Mini	Name	Cable color	Description
1	1	1	Vcc	Red	+5V (can dip to 4.08V)
2	2	2	D-	White	Data -
3	3	3	D+	Green	Data +
-	4	4	ID	-	Type A: Connect to ground Type B: Not connected
4	5	5	Gnd	Black	Signal ground

For ultra-low cost products, it is possible to form a USB Type-A plug direct from a circuit board as shown in figure 7. This connector is only suitable for a number of insertions (~50 before cleaning is required). It is unshielded and recommended only for 'dongle' type products with no cables attached.

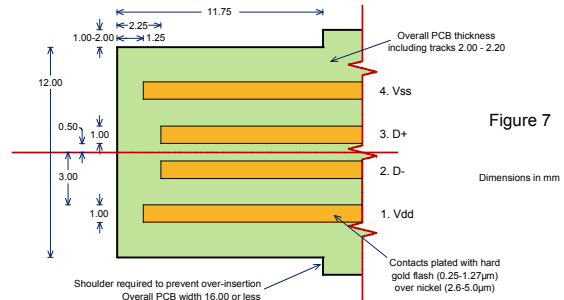

Figure 7

Dimensions in mm

For further dimensional information, refer to figure 6-7 of the USB 2.0 Specification, in the development kit.

Host-Side Interfacing

- Prior to writing your own software, you can use the *HIDconfig.exe* software in the development kit to evaluate USB-SPI.

USB-I2C uses the Human Interface Device (HID) USB interface. It has the advantages that no device drivers are required, and that a host application can easily locate the USB-I2C.

All exchanges of data ('reports') between the host and the USB-I2C are 64 bytes in length, regardless of how many bytes of meaningful data are actually transferred. In HID terms, all transfers are 1ms interrupt reports of 64 bytes, to and from output ID 0 on EP1.

The host software has two perform two tasks. First it has to locate the device. Then it has to communicate with it. To locate the device, enumerate all devices with Vendor ID 0x0B40 and Product ID 0x011C (28-pin devices) or 0x012B (20-pin devices). Then use a Get Feature request for the string 4, the Product GUID. If this matches the product GUID you configured for the device, you have located it.

Once you have located the device, you need to open a file to communicate with it. You can then send data and receive data as 64-byte reports.

Sample source code for Windows and a Windows dynamic link library (DLL) are provided in the development kit. For a detailed description, please refer to the comments embedded in the source code and the Visual Basic example in the Excel spreadsheet. Sample source code for Mac OS and Linux is in preparation.

Sending and Receiving Data

The first byte of the report (byte 0) is termed the identifier. If its value is 0x01-0x3F, then it indicates that the packet is data for transmission to or received from the TxD and RxD pins. The value equals the number of data bytes being transferred. The data is located from byte 1 of the report onwards.

If its value is 0x41-0x7F, it should be interpreted exactly the same as 0x01-0x3F except the value equals the number of data bytes being transferred plus 0x40, and the report must be acknowledged before the next data report is sent. A data report is acknowledged by sending a report with an identifier of value 0x40.

(Note: Prior to rev 0007, the maximum number of data bytes is 0x3E, i.e. the identifiers 0x3F and 7F are not permitted.)

Commands

All commands are sent using identifiers of value 0x80 or higher. If a response to the command is required, the response will have the same identifier as the command to which it is responding. The Interrupt response has no command associated with it and it may be received by the host at any time.

Note: Accidentally sending a command in the range 0x80-0x8F can modify settings that may permanently disable the device. During product development, it is recommended that you work with a device that has been write locked using HIDconfig.exe. Devices intended for production should always be write locked.

Get Pin

The identifier GETPIN (0x90) retrieves value of a pin. The command payload has one byte, which indicates the pin, as shown in table 6. The response payload has two bytes, as shown in table 6.

Example:

```
90 25      Command – Get DTR pin
90 25 01   Response – Pin is active
```

Get Analog

The identifier GETANALOG (0x96) retrieves the voltage of the analog pin. The command has no payload. The response payload has two bytes, representing a number from 0x0000 to 0x03FF, which indicates the voltage relative to Vdd.

Example:

```
96          Command – Get Analog
96 02 36    Response – V = Vdd * (0x236/0x3FF)
```

Set Pin

The identifier SETPIN (0x91) sets the value of any output pin. The command payload has two bytes, which indicate the pin and the desired output.

Example:

```
91 25 01    Command – Set DTR pin active
```

Pin	Payload byte 1	Payload byte 2**
VIO0	0x10	00 = Low, 01 = High
VIO1	0x11	00 = Low, 01 = High
VIO2	0x12	00 = Low, 01 = High
VIO3	0x13	00 = Low, 01 = High
VIO4	0x14	00 = Low, 01 = High
VIO5	0x15	00 = Low, 01 = High
VIO6	0x16	00 = Low, 01 = High
VIO7	0x17	00 = Low, 01 = High
VIO8	0x18	00 = Low, 01 = High
VIO9	0x19	00 = Low, 01 = High
VIO10	0x1A	00 = Low, 01 = High
USBPwr	0x20	00 = Inactive, 01 = Active
SelfPwr	0x21	00 = Inactive, 01 = Active
HostRdy	0x26	00 = Inactive, 01 = Active
Send †	0x27	00 = Inactive, 01 = Active

Pin	Payload byte 1	Payload byte 2**
TxInd	0x28	00 = Inactive, 01 = Active
RxInd	0x29	00 = Inactive, 01 = Active
AllSysGo	0x2A	00 = Inactive, 01 = Active
Config	0x2B	00 = Inactive, 01 = Active
Suspend	0x2C	00 = Inactive, 01 = Active
LowPower	0x2D	00 = Inactive, 01 = Active
TxBuffEmpty †	0x2E	00 = Inactive, 01 = Active
TxRxInd	0x30	00 = Inactive, 01 = Active
RxBuffNotFull †	0x34	00 = Inactive, 01 = Active

*Byte 0 is the identifier 0x90 (Get Pin) or 0x91 *Set Pin)
 ** Used in Get Pin Response and Set Pin Command only
 † Not settable

Host Ready

The Host Ready feature is used to indicate to the device that a host application is running, has located the device, and is ready to communicate with it.

If the Host Ready pin is implemented, the application should tell the device when it is ready using the Host Ready command. It consists of the identifier HOSTREADY (0x92) and one payload byte, which is 0x01 if the application is initialized and available, or 0x00 if the application is shutting down and not longer available.

Interrupt

The Interrupt response is an unprompted message from the device that an interrupt input transitioned from the inactive to the active state.

It consists of the identifier INTERRUPT (0x95) and one payload byte, which is 0x09 if the interrupt occurred on pin VIO9.

Set Serial

The identifier SETSERIAL (0x93) temporarily sets the mode of operation of the I2C port. These settings are not remembered after device reset and should be used if the settings are to be adjusted under software control. The command payload has 2 bytes as shown in table 7. Slew is a feature of the I2C port which should be enabled in high speed mode (400kHz clock).

Example:

```
92 02 FF    Command – No Ack, Slew On, Null Tx
              Char is 0xFF
```

Byte	Name	Description / Value
0	Identifier	0x92
1	Flags	Bit 0 set for data Acknowledged Bit 2 set if Slew is to be enabled All other bits: set to zero
2	NullTxCh	Null Tx character

Get Firmware ID

The identifier GETFWID (0x94) retrieves a zero-terminated ASCII text string identifying the firmware and its version number.

Example:

```
94          Command – Get Firmware ID
94 55 53 42 2D 49 32 43 20 30 31 2E 30 30 00
              ("USB-I2C 01.00")
```

Customization

The product can be customized in one of three ways:

1. Using the *HIDconfig.exe* application (figure 8) in the development kit. This application makes it very easy to copy the configuration from an existing product to a new product and is suitable for in-factory use. (It cannot be used if you have changed the Vendor ID and / Product ID.)
2. By requesting the custom settings to be supplied pre-programmed when buying pre-programmed chips (5K units minimum).
3. Using customization commands. Documentation on these commands is available on request.

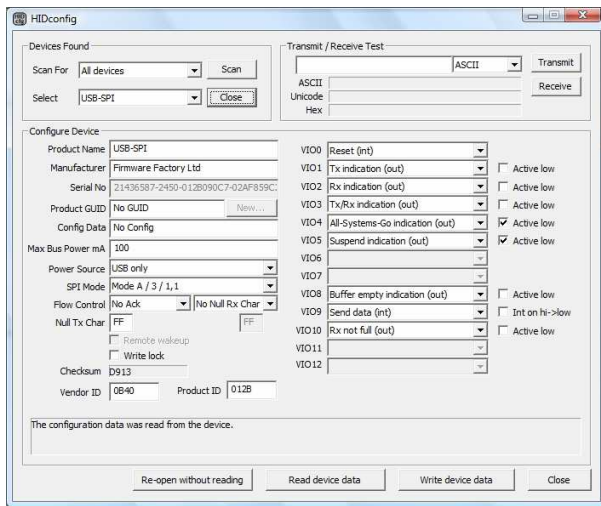

Figure 8. *HIDconfig.exe* application

Delivery and Programming

USB-I2C is available pre-programmed in 28-pin DIL and 20-pin SSOP packages. USB-I2C-SS (SSOP package) may be supplied with an ID label, or it may be identified with a blue mark on the package.

In high volumes (5K+), USB-I2C is available reeled with your custom settings preloaded, in any available package.

TEAclipper Programming

If practical, a TEAclipper programming socket should be added to the circuit board in order to facilitate in-circuit firmware updates.

During programming, these connections must be protected against contention. In particular, note that *Vpp* is subject to 13V during programming. Nothing else should be connected to *Vpp* except via a 22k pull-up resistor.

The TEAclipper connector format is shown in figure 9. Since the programming time is fast, no programming socket is required. The TEAclipper can be 'leaned' against the plate-through holes shown.

It is strongly recommended that this connector is included in circuits even if in-circuit programming is not anticipated, since this allows you to upgrade the firmware if necessary.

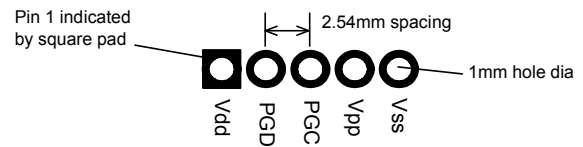

Figure 9. Recommended plate-through connector design

Evaluation Board

USB-I2C may be evaluated with the Firmware Factory USB Products Eval Board (figure 10). The components which must be fitted are shown in table 5. In addition, the following connections must be made:

- Jumper A to Jumper C.
- Active low LED to pin 3 (RA1) pf U7.
- Active high pushbutton to pin 4 (RA2) pf U7.
- Pin VIO9 / Send to Vdd.
- Jumper J to Jumper K (20 pin device only)
- Jumper L to Jumper M (20 pin device only)

The prototyping area on the left of the board may be used to add the LED and pushbutton. In figure 11, an active low LED has been connected to the AllSysGo# pin and active high LEDs to the Tx and Rx indicators, and a jumper provided on the Send input. (Some connections are on the underside of the board.)

The printed circuit board integrates an edge connector of USB Type A format. This may be plugged into a USB extension cable.

Table 5. Evaluation Board bill of materials	
Label	Component
U2	USB-I2C-DIL
U7	PIC18F2321
D2	Wire link
C4d, C6	100nF capacitor
C7	10uF capacitor
C8	470nF capacitor
C2, C3	22pF capacitor
X1	12MHz parallel cut crystal
R2, R3	22k resistor
R4, R5	4k7 resistor

The PIC18F2331 serves as an I2C master for the evaluation. When the pushbutton is pressed, the LED lights. Eight bytes are then sent to USB-I2C and eight bytes are read from USB-I2C. The first time the button is pressed, the bytes 12 34 56 78 9A BC DE F0 are sent. Thereafter, the previously received eight bytes are echoed back. The source code for the I2C host is in the development kit.

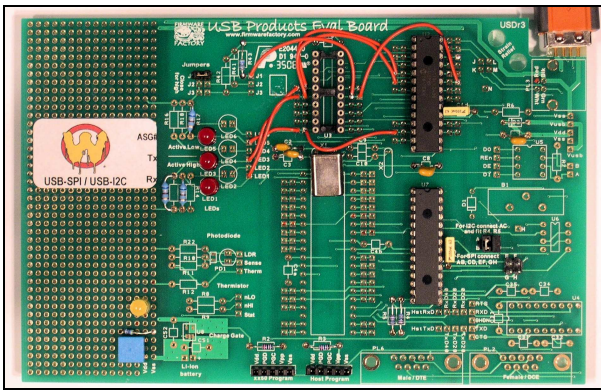

Fig 10. USB Products Eval Board

Development Kit

A firmware development kit is available for download from www.hexwax.com containing the following files:

- Base controller data sheets (© Microchip Technology Inc)
- *USB 2.0 Specification* (© HP / Intel / Lucent / Microsoft / NEC / Philips 2000)
- *HIDconfig.exe* for in-factory customization of USB-I2C devices via the USB port.
- *AN1149 Designing a Li-Ion charger system...* for design examples on charging batteries from USB power (© Microchip Technology Inc 2006)
- *usb-win.c* and *usb-win.h*, sample HID code for Windows. Additionally the files *setupapi.h*, *hidsdi.h*, *hidpi.h*, *setupapi.lib* and *hid.lib* are provided, which must be included in the project.
- *FwFhid.dll* dynamic link library and Visual Basic example *FwFhidDLLExample.xls*.
- *USB-I2C Host* project files for the evaluation host controller.

Warranty

The warranty and liability provisions for this pre-loaded software product follow software industry conventions. Please refer to www.hexwax.com and/or www.flexipanel.com for a complete warranty statement.



Firmware Factory Ltd
 2 Marshall St, 3rd Floor
 London W1F 9BB, UK
sales@firmwarefactory.com
support@firmwarefactory.com