

StickIt! Board Manual

*How to install and use
your new StickIt! Board*

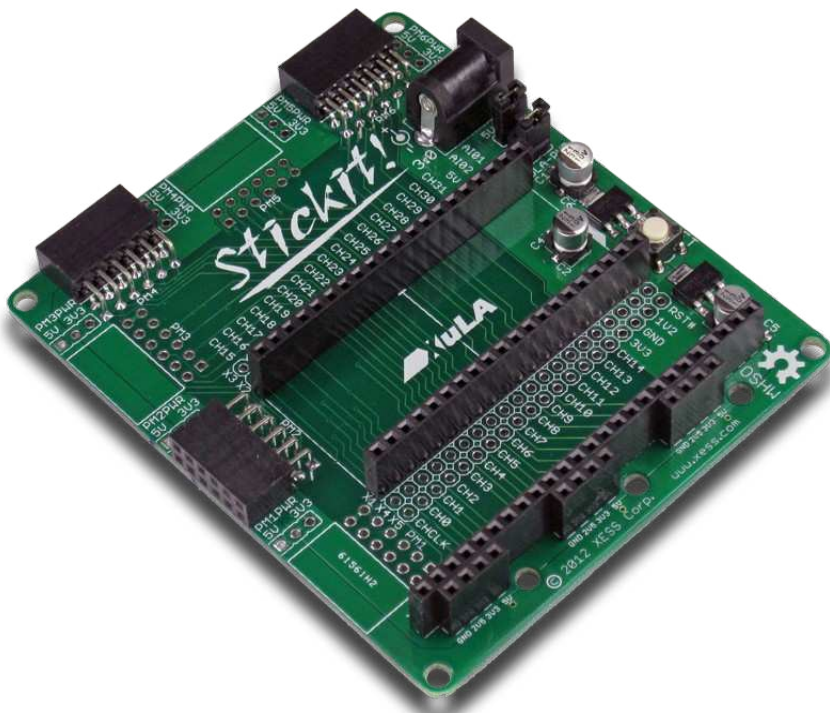

XESS is disclosing this Document and Intellectual Property (hereinafter “the Design”) to you for use in the development of designs to operate on, or interface with XESS hardware devices. XESS expressly disclaims any liability arising out of the application or use of the Design. XESS reserves the right to make changes, at any time, to the Design as deemed desirable in the sole discretion of XESS. XESS assumes no obligation to correct any errors contained herein or to advise you of any correction if such be made. XESS will not assume any liability for the accuracy or correctness of any engineering or technical support or assistance provided to you in connection with the Design.

THE DESIGN IS PROVIDED “AS IS” WITH ALL FAULTS, AND THE ENTIRE RISK AS TO ITS FUNCTION AND IMPLEMENTATION IS WITH YOU. YOU ACKNOWLEDGE AND AGREE THAT YOU HAVE NOT RELIED ON ANY ORAL OR WRITTEN INFORMATION OR ADVICE, WHETHER GIVEN BY XESS, OR ITS AGENTS OR EMPLOYEES. XESS MAKES NO OTHER WARRANTIES, WHETHER EXPRESS, IMPLIED, OR STATUTORY, REGARDING THE DESIGN, INCLUDING ANY WARRANTIES OF MERCHANTABILITY, FITNESS FOR A PARTICULAR PURPOSE, TITLE, AND NONINFRINGEMENT OF THIRD-PARTY RIGHTS.

IN NO EVENT WILL XESS BE LIABLE FOR ANY CONSEQUENTIAL, INDIRECT, EXEMPLARY, SPECIAL, OR INCIDENTAL DAMAGES, INCLUDING ANY LOST DATA AND LOST PROFITS, ARISING FROM OR RELATING TO YOUR USE OF THE DESIGN, EVEN IF YOU HAVE BEEN ADVISED OF THE POSSIBILITY OF SUCH DAMAGES. THE TOTAL CUMULATIVE LIABILITY OF XESS IN CONNECTION WITH YOUR USE OF THE DESIGN, WHETHER IN CONTRACT OR TORT OR OTHERWISE, WILL IN NO EVENT EXCEED THE AMOUNT OF FEES PAID BY YOU TO XESS HEREUNDER FOR USE OF THE DESIGN. YOU ACKNOWLEDGE THAT THE FEES, IF ANY, REFLECT THE ALLOCATION OF RISK SET FORTH IN THIS AGREEMENT AND THAT XESS WOULD NOT MAKE AVAILABLE THE DESIGN TO YOU WITHOUT THESE LIMITATIONS OF LIABILITY.

The Design is not designed or intended for use in the development of on-line control equipment in hazardous environments requiring fail-safe controls, such as in the operation of nuclear facilities, aircraft navigation or communications systems, air traffic control, life support, or weapons systems (“High-Risk Applications”). XESS specifically disclaims any express or implied warranties of fitness for such High-Risk Applications. You represent that use of the Design in such High-Risk Applications is fully at your risk.

© 2012 XESS, Inc. XESS, the XESS logo, and other designated brands included herein are trademarks of XESS Corporation. PMOD is a trademark of Digilent Inc. All other trademarks are the property of their respective owners.



This document is licensed under the Attribution-ShareAlike 3.0 Unported license, available at <http://creativecommons.org/licenses/by-sa/3.0/>.

StickIt! Board Manual
MAN002 (V3.0) December 11, 2012

The following table shows the revision history for this document.

Date	Version	Revision
01/15/12	1.0	Initial release for StickIt! board V1.0.
09/23/12	2.0	Revised for StickIt! board V2.0.
12/11/12	3.0	Revised for StickIt! Board V3.0.

Table of Contents

- C.1 Preliminaries..... 1**
 - Getting Help!..... 1
 - Take Notice!..... 1
 - Packing List..... 1
- C.2 Setup..... 2**
 - Inserting a XuLA Board into Your StickIt! Board..... 2
 - Applying Power to Your StickIt! Board..... 3
 - Applying Power Through the USB Port..... 3
 - Applying Power Through the Power Jack..... 4
 - Applying Power to Stand-Alone Applications..... 5
- C.3 Connections..... 7**
 - XuLA Board Socket..... 7
 - Voltage Regulators..... 8
 - PMOD Connectors..... 9
 - Wing Connectors..... 12
- C.4 Using Modules..... 13**
- A.1 I/O Locations..... 15**
- A.2 Schematic..... 18**

C.1 Preliminaries

Here's some helpful information before getting started.

Getting Help!

Here are some places to get help if you encounter problems:

- If you can't get the StickIt! board to work, send an e-mail message describing your problem to help@xess.com or submit a problem report at <http://www.xess.com/help.php>. Our web site also has
 - answers to frequently-asked-questions,
 - example designs, application notes and tutorials,
 - a forum where you can post questions.

Take Notice!

- The XuLA Board is not 5V-tolerant. **Do not connect 5V logic signals to the PMOD™ or Wing sockets of the StickIt! board.**
- **Only power the StickIt! board with a regulated 5 VDC, center-positive power supply.**

Packing List

Here is what you should have received in your package:

- a StickIt! board.

C.2 Setup

The StickIt! board accepts a XuLA FPGA board and provides it with connections to separate StickIt! modules such as LED displays, buttons, audio I/O, etc.

Inserting a XuLA Board into Your StickIt! Board

You insert a XuLA board into the central row of sockets on the StickIt! board as shown below. Make sure XuLA prototyping header pins line-up with the sockets and that the USB connector is oriented towards the StickIt! board RESET button.

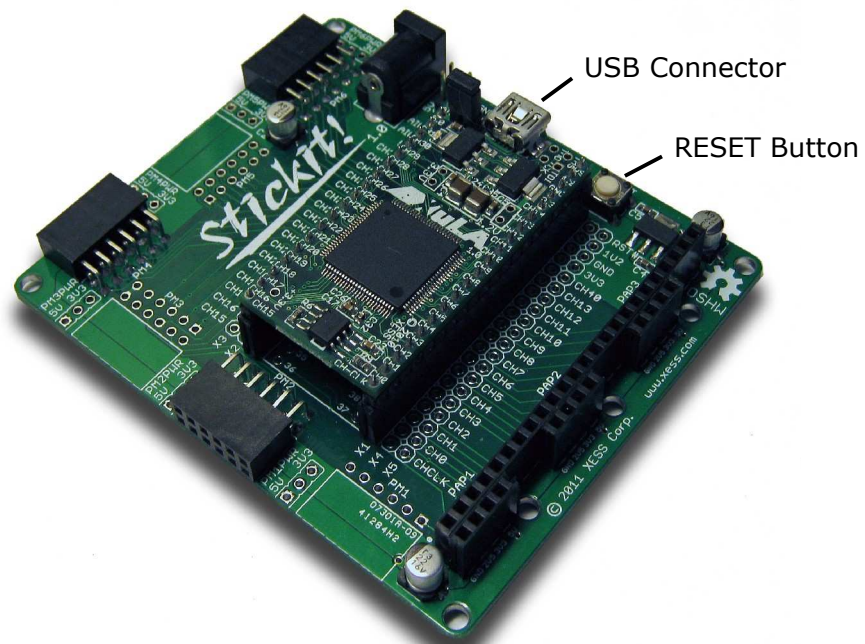

To insure a stable connection with the StickIt! board, the XuLA board should have 0.25" square posts soldered into its prototyping header. **The 0.19" round posts used for mounting a XuLA into a solderless breadboard should not be used or else intermittent connections will occur!**

Applying Power to Your StickIt! Board

There are several ways to power the combination of your XuLA and StickIt! board. Each of these will be discussed below.

Applying Power Through the USB Port

Connecting the XuLA Board to a USB port provides it with a 5V supply capable of delivering up to 500 mA of current. The 5V supply can also power the StickIt! board and any attached StickIt! modules by placing a shunt on the XULA-PWR jumper as shown below.



Applying Power Through the Power Jack

For applications that require more power than the USB port can provide, you can attach a regulated, 5 VDC center-positive power adapter to the 5VDC jack on the StickIt! board. In this case, the shunt should be removed from the XULA-PWR jumper and placed on the 5V-PWR jumper on the StickIt! board as shown below. In this configuration, the USB port powers the XuLA board while the adapter powers the StickIt! board and any attached StickIt! modules.



Applying Power to Stand-Alone Applications

For applications that operate stand-alone with no connection to a USB port, you can attach a regulated, 5 VDC center-positive power adapter to the 5VDC jack on the StickIt! board. In addition, shunts should be placed on both the XULA-PWR and 5V-PWR jumpers as shown below. This will transfer power from the adapter through the StickIt! board to the XuLA board.

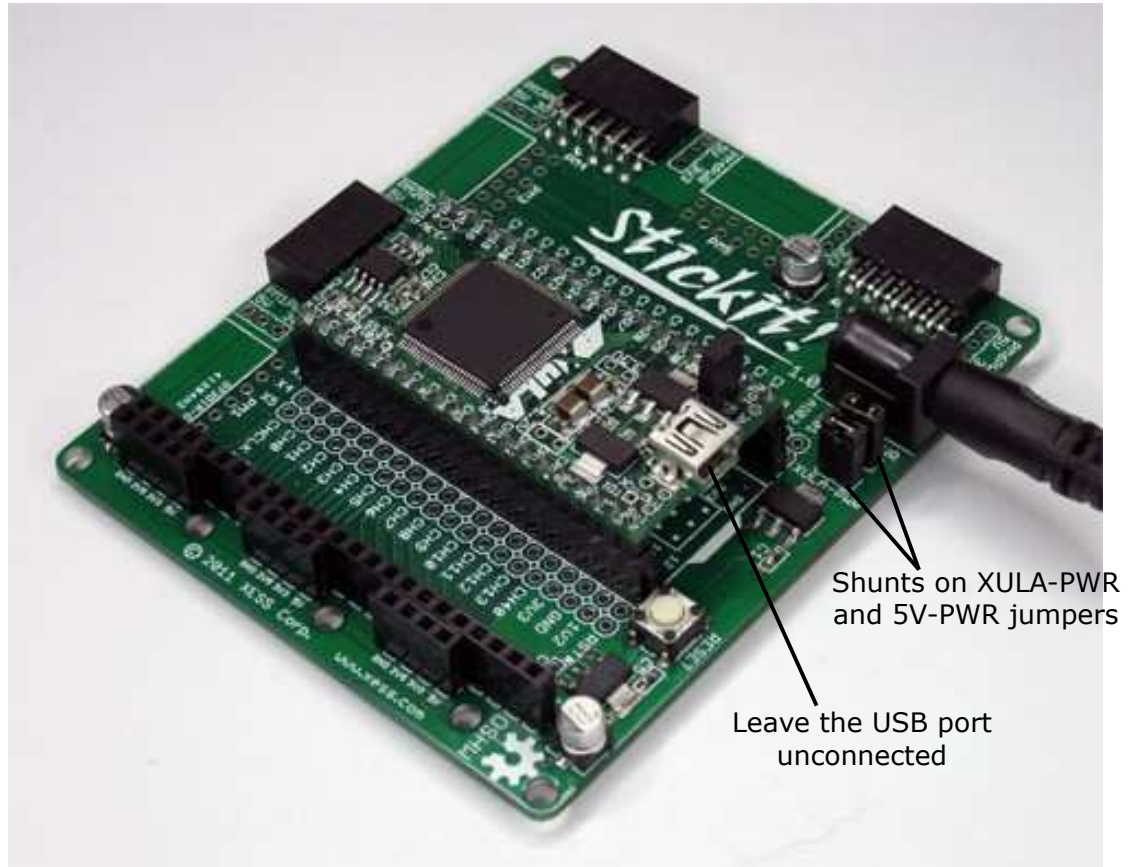

A USB cable should not be attached to the XuLA board in this configuration or damage may result from the direct connection of the power adapter to the 5V supply pin of the USB port.

In order to prevent inadvertent damage, you can remove the 5V shunt on the XuLA board to disconnect the USB 5V supply as shown below. Note that doing this will prevent you from powering the XuLA through the USB port until the 5V shunt is restored.



C.3 Connections

This chapter describes the various sections of the StickIt! board and shows how the XuLA board I/O connects to them. In addition to the partial schematics used below, you can find a complete [schematic](#) at the end of this manual.

XuLA Board Socket

The XuLA Board connects to the StickIt! board through the X1 socket. In addition, there are four more 20x1 socket strips (X2 - X5) adjacent to X1 that provide access to the XuLA board I/O after it is plugged into the StickIt! board.

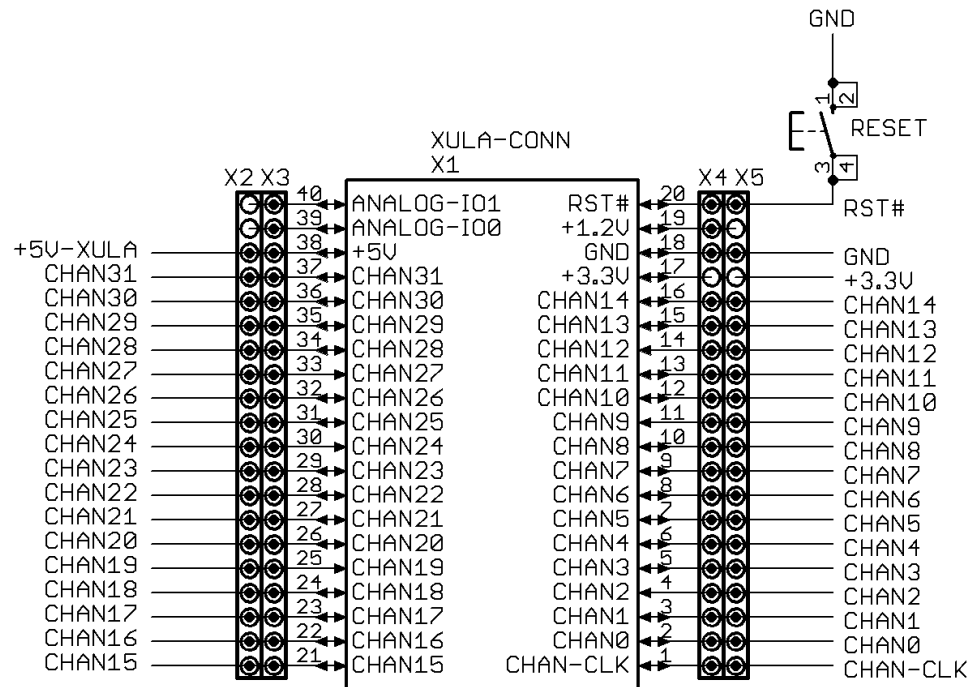

Please note the following:

- All the XuLA I/O channels (CHAN0 – CHAN31) and the channel clock (CHAN-CLK) are connected to the X2 – X5 sockets, but only 24 of these signals are then routed out to the PMOD and Wing sockets. (CHAN2, CHAN9, CHAN12, CHAN19, CHAN24, CHAN27, CHAN29, CHAN30 and CHAN31 **do not connect** to the PMOD and Wing sockets.)

- The XuLA 5V pin is connected to the +5V-XULA signal on the StickIt! board. This allows the XuLA board to send power to or receive power from the StickIt! board. This is the only voltage supply shared by both the XuLa and StickIt! boards.
- The XuLA 3.3V pin is connected to the X4 socket, but it does not connect to the 3.3V supply of the StickIt! board (which connects to the X5 socket).
- The XuLA 1.2V pin is connected to the X4 and X5 sockets, but this voltage supply does not connect to anything else on the StickIt! board.
- The XuLA ground is connected to the StickIt! board ground.
- The reset pin of the XuLA board connects to the X4 and X5 sockets and also to the RESET pushbutton on the StickIt! board. Pushing this button resets the XuLa board.
- The analog I/O pins of the XuLA board connect to the X2 and X3 sockets but these signals do not connect to anything else on the StickIt! board.

Voltage Regulators

The StickIt! board accepts +5V from either the XuLa board (when there is a shunt on jumper XULA-PWR) or an external power supply (when there is a shunt on jumper 5V-PWR). The StickIt! board voltage regulators create the additional +3.3V and +2.5V supplies.

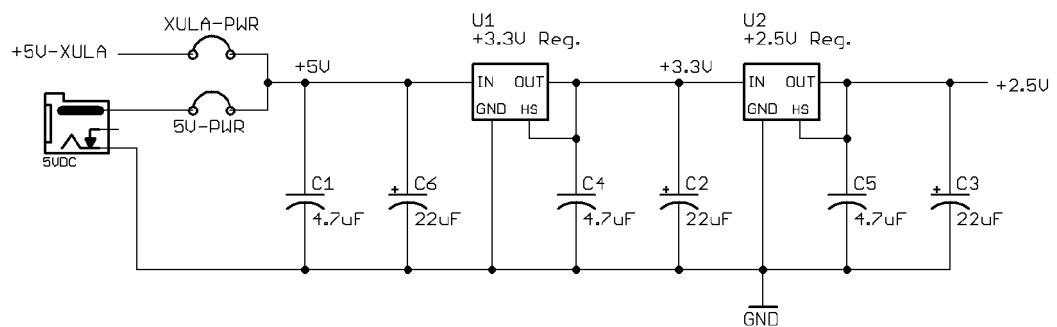

Be aware that placing shunts on both the XULA-PWR and 5V-PWR jumpers will connect the external power supply to the XuLA board power supply. **This will cause damage** unless 1) the USB cable is removed from the XuLA board, or 2) the 5V jumper on the XuLA board is open. (Note that in its factory-original configuration, the 5V jumper on the XuLA board is shorted by a wiring trace on the bottom of the PCB which must be cut to disconnect the 5V supply from the USB port.)

PMOD Connectors

There are six sockets for connecting external PMOD modules to the StickIt! board.



All of these sockets (PM1 - PM6) accept either four-bit or eight-bit PMOD modules.

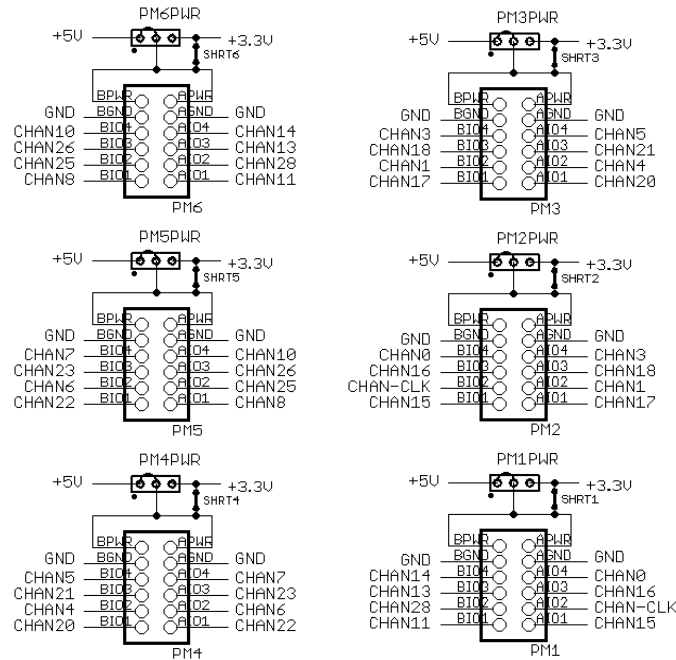

A total of 24 I/O signals connect from the XuLa board to the PMOD (and Wing) sockets, so you can use any combination of modules that require 24 total I/Os or less. For example, you could connect three eight-bit modules, or two eight-bit modules and two four-bit modules, or six four-bit modules, etc.

Note that each PMOD socket shares four I/O lines with each of its adjacent PMOD sockets, so there must be an empty socket between any pair of eight-bit modules or else they will have I/O conflicts. For example, connecting eight-bit modules to sockets PM2, PM4 and

PM6 is OK, but using PM2, PM3 and PM6 would cause a conflict between PM2 and PM3 on I/O lines CHAN3, CHAN18, CHAN1 and CHAN17. (Connecting a Wing module will also consume I/O resources and may cause additional conflicts.)

Each PMOD socket has an associated jumper to connect either the 3.3V or 5V power supply to the attached module. In their factory-original configuration, each of these jumpers is set to 3.3V by a shorting trace on the bottom of the StickIt! board PCB. You must cut this trace and install a jumper and shunt if you want to use a 5V module.

Wing Connectors

There are three sockets for connecting external eight-bit Wing modules to the StickIt! board.

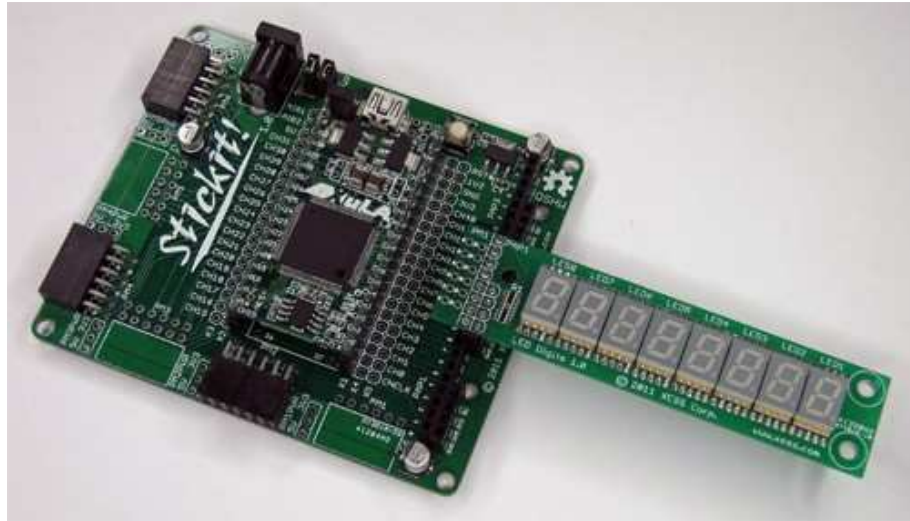

The Wing sockets are placed end-to-end so you can also use a 16- or 24-bit Wing module (if such a thing exists). A total of 24 I/O signals connect from the XuLa board to the Wing sockets, so you can use any combination of modules that require 24 total I/Os or less. For example, you could connect three eight-bit modules, or one eight-bit module and a 16-bit module.

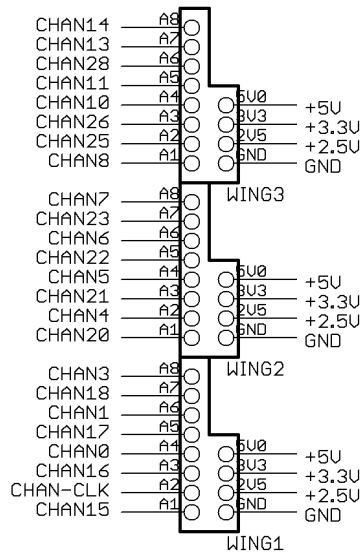

Unlike the PMOD sockets, there are no I/O lines shared between the Wing sockets. However, the Wing sockets do share the same I/O lines used by the PMOD sockets, so there can be conflicts depending upon which PMOD and Wing sockets are used in an application.

Each Wing socket connects to the 5V, 3.3V and 2.5V supplies on the StickIt! board, so there is no need for a jumper to select which supply powers the attached Wing module.

C.4 Using Modules

Using a PMOD or Wing module with the StickIt! board is easy. Just do the following:

- Attach the module to either a PMOD or Wing socket on the StickIt! board.
- Determine the channel signals on the PMOD or Wing socket that connect to each I/O of the module.
- Find which FPGA pin of the XuLA board connects to each channel signal.
- Make a UCF file associating each FPGA pin with each I/O of the module.
- Include the UCF file in your Xilinx ISE FPGA project.

As an example, consider a simple eight-bit Wing module with eight LEDs, each connected to one of the I/O signals like so:

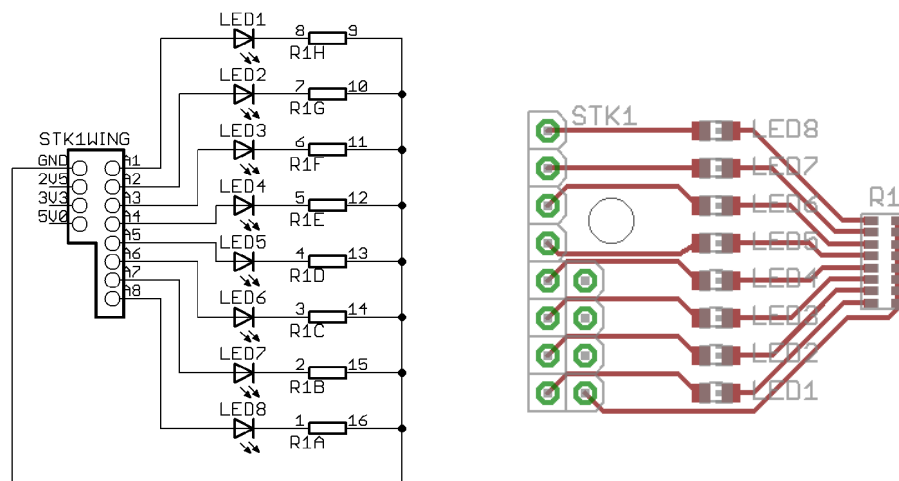

If this module is attached to the Wing socket WING1, then the channel connections are:



Assuming a XuLA-200 board is plugged into the StickIt! board, then the FPGA pins connected to these channels are (from the XuLA manual):

CHAN15	p35
CHAN-CLK	p44
CHAN16	p34
CHAN0	p36
CHAN17	p33
CHAN1	p37
CHAN18	p32
CHAN3	p50

From this, you can make the following pin assignments in a UCF file:

```
NET led1 LOC = p35; # CHAN15
NET led2 LOC = p44; # CHAN-CLK
NET led3 LOC = p34; # CHAN16
NET led4 LOC = p36; # CHAN0
NET led5 LOC = p33; # CHAN17
NET led6 LOC = p37; # CHAN1
NET led7 LOC = p32; # CHAN18
NET led8 LOC = p50; # CHAN3
```

Then include this UCF file in your ISE project.

A.1 I/O Locations

The connections of the XuLA and XuLA2 board I/O channels to the PMOD and Wing sockets of the StickIt! board are shown below.

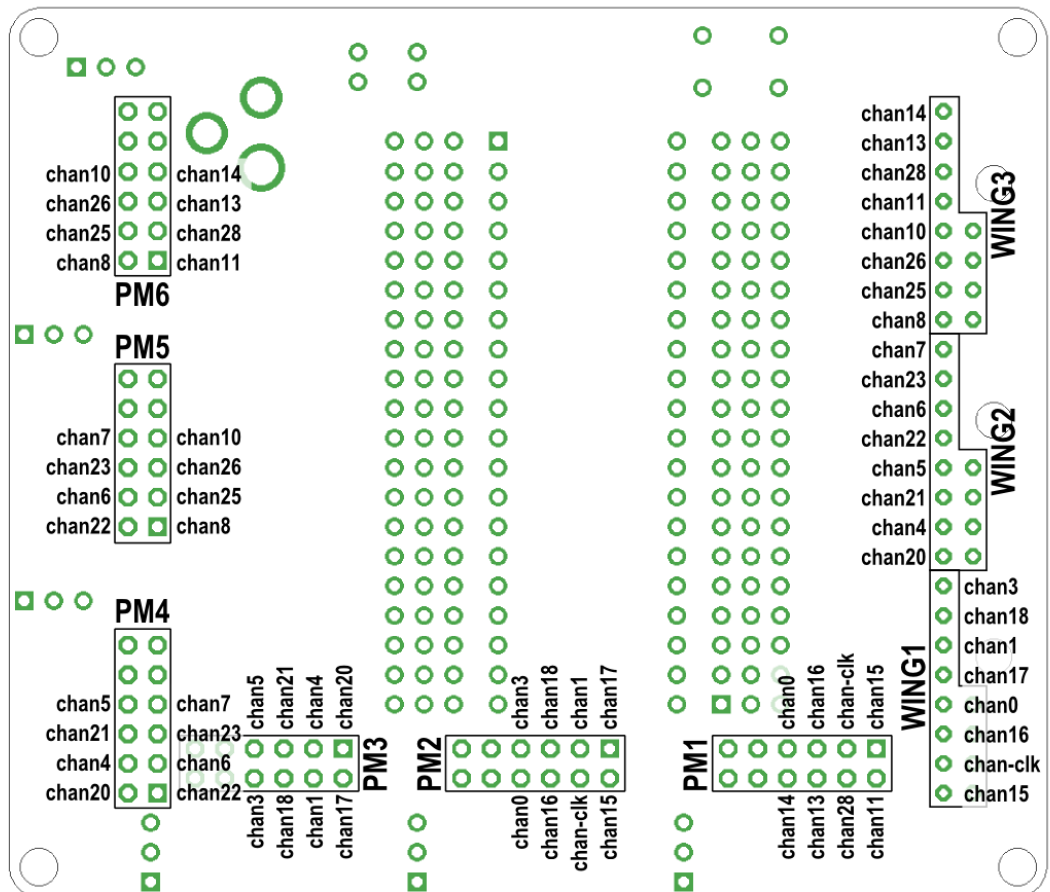

The next figure shows the association between the PMOD and Wing socket I/Os and the actual I/O pin numbers of the FPGA on the **XuLA** board.

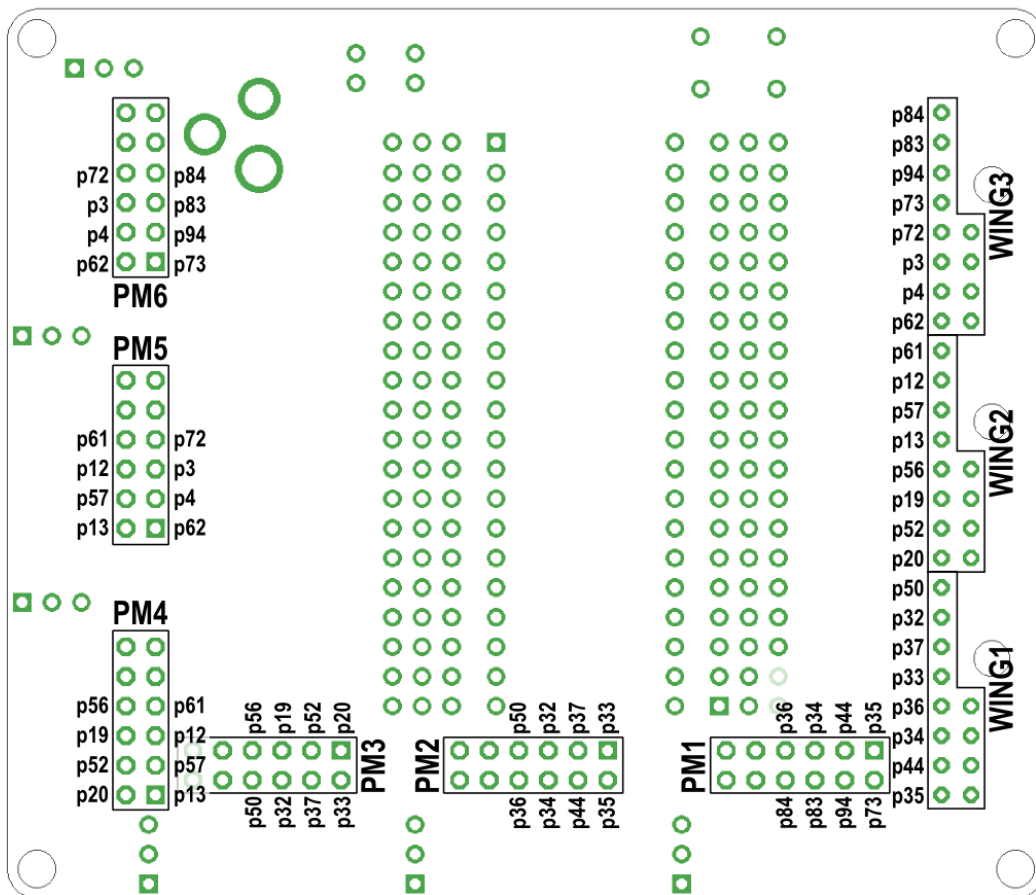

And this figure shows the association between the PMOD and Wing socket I/Os and the actual I/O pin numbers of the FPGA on the **XuLA2** board.

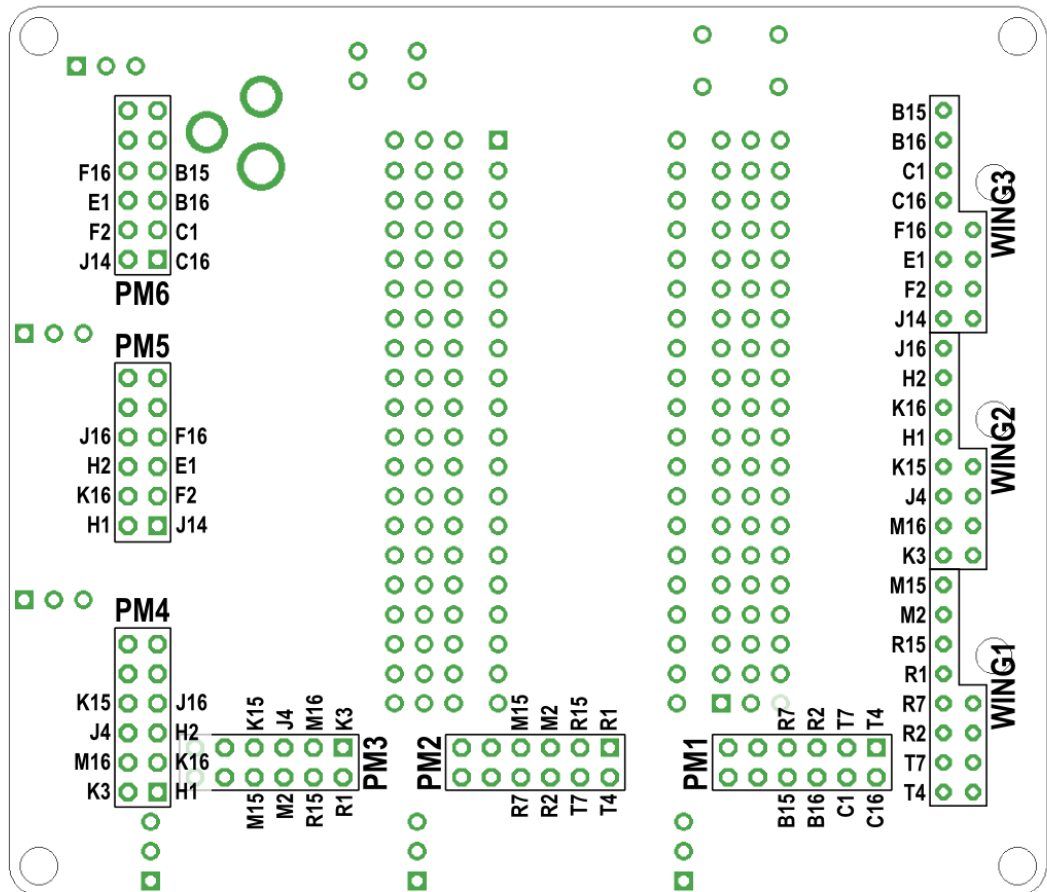

A.2 *Schematic*

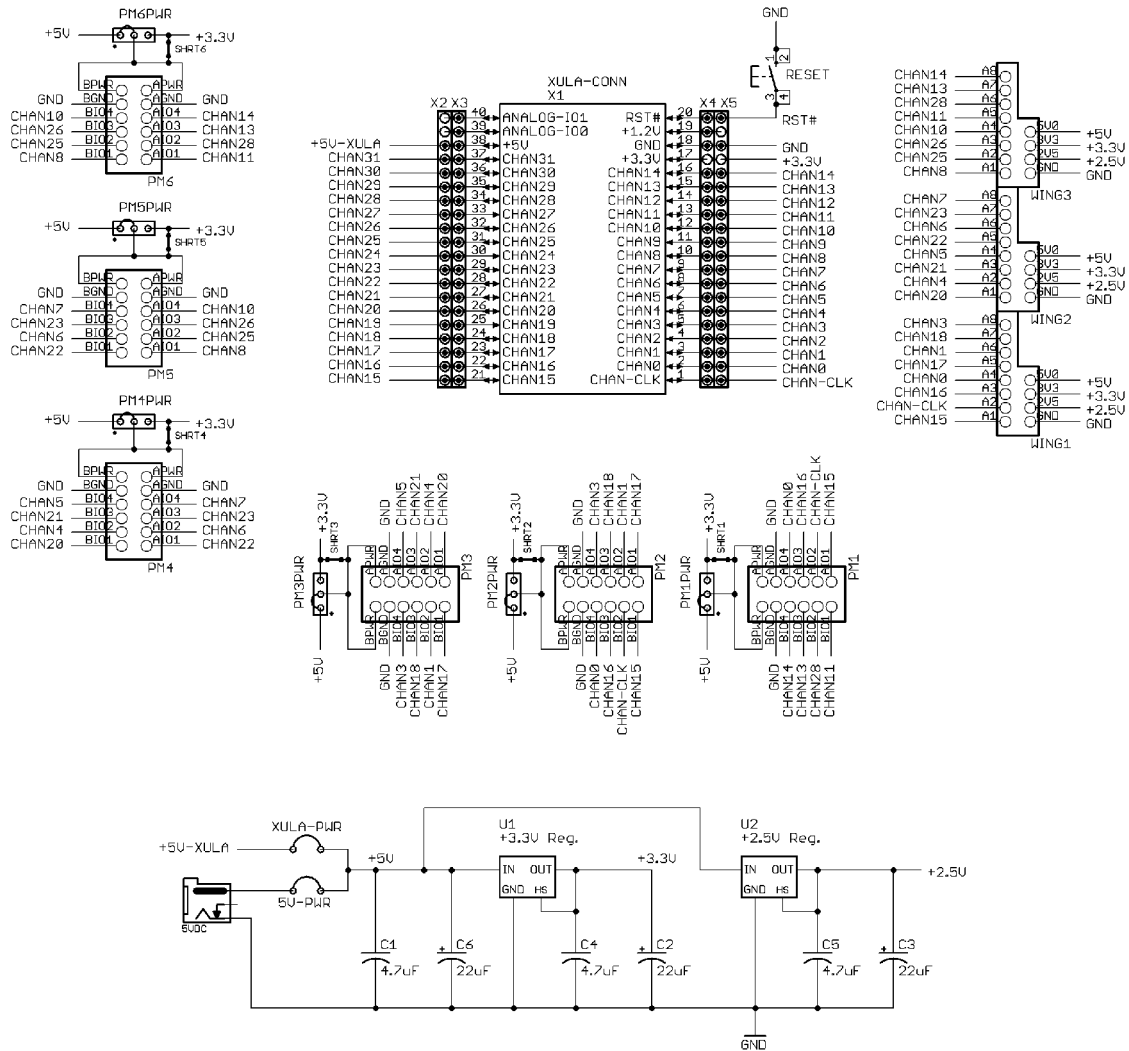

© 2012, XESS Corp. Some rights reserved.
 Licensed under a Creative Commons Attribution-Share-Alike Unported License. See creativecommons.org/licenses/by-sa/3.0/

StickIt!			
PROJECT: StickIt	REV: 3.0	Date: not saved!	
AUTHOR: Dave Vandebout / XESS Corp.			Sheet: 1/1