

# HummingBoard Schematics

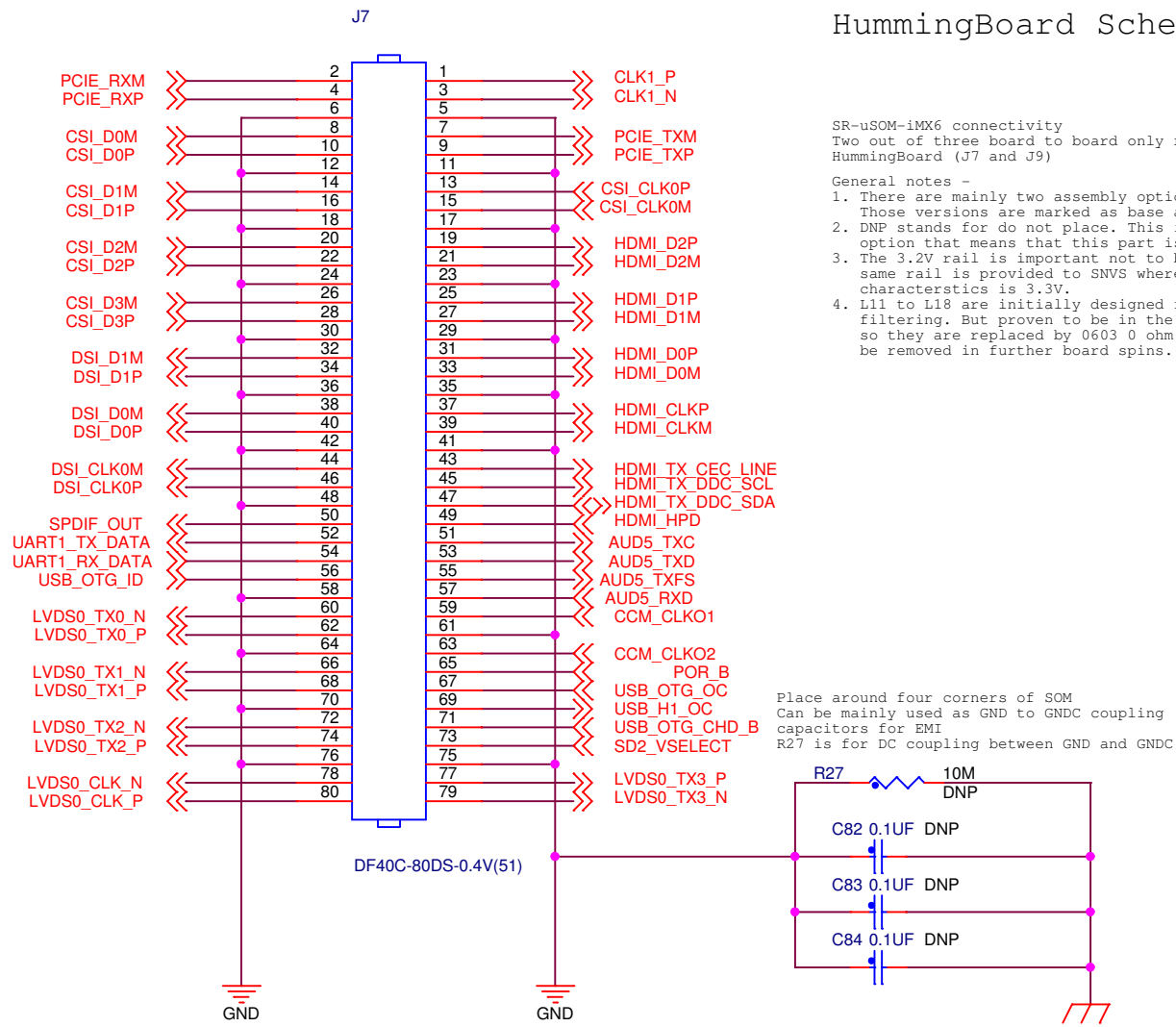

SR-uSOM-iMX6 connectivity  
Two out of three board to board only required by HummingBoard (J7 and J9)

General notes -

1. There are mainly two assembly options versions. Those versions are marked as base and pro. DNP stands for do not place. This is assembly option that means that this part is not assembled.
2. The 3.2V rail is important not to be 3.3V since the same rail is provided to SNVS where it's max AC characteristics is 3.3V.
3. L11 to L18 are initially designed ferrite beads for EMI filtering. But proven to be in the lab to be un-needed so they are replaced by 0603 0 ohm resistors and will be removed in further board spins.

Place around four corners of SOM  
Can be mainly used as GND to GNDC coupling capacitors for EMI  
R27 is for DC coupling between GND and GNDC

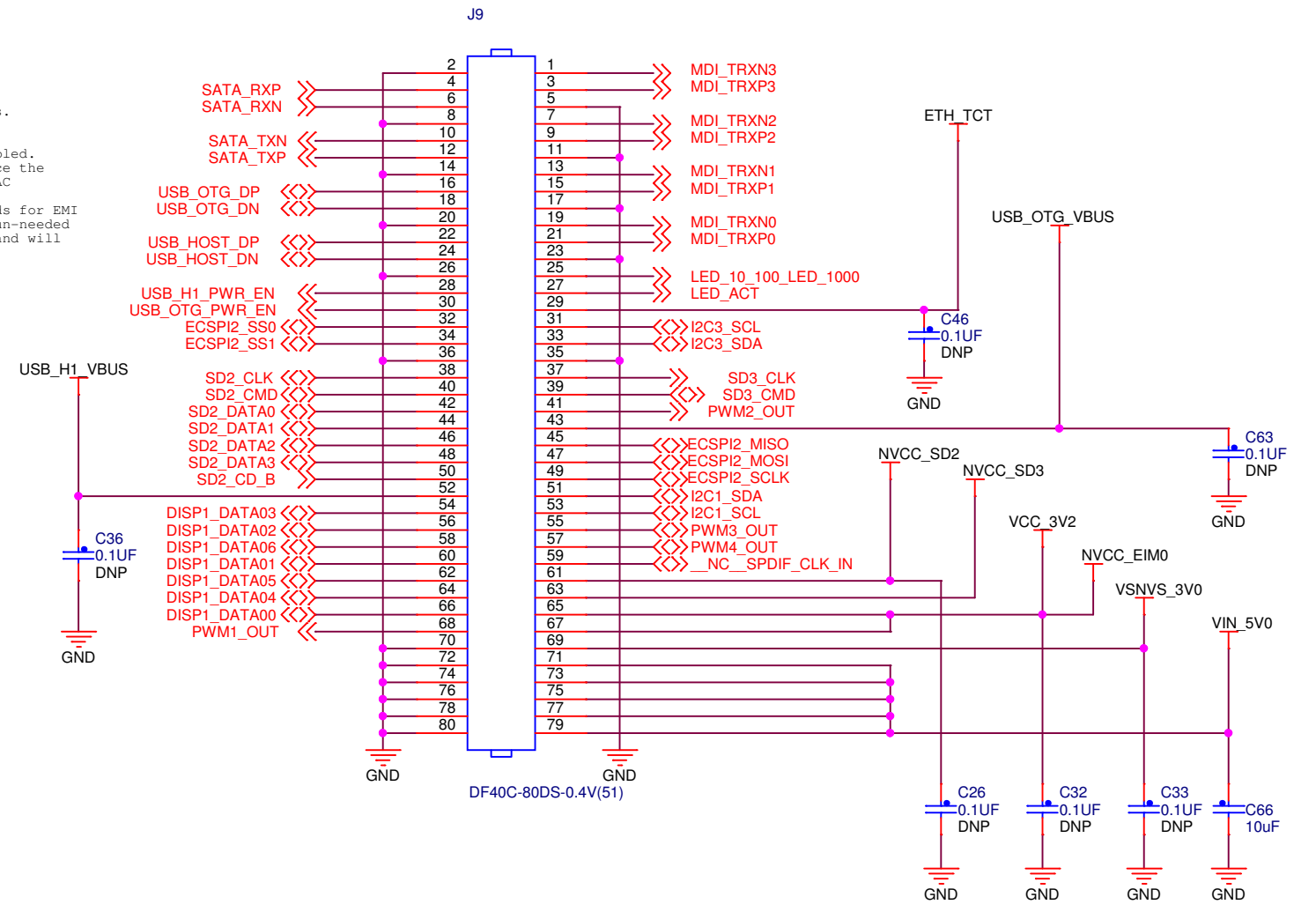

5V micro USB DC in

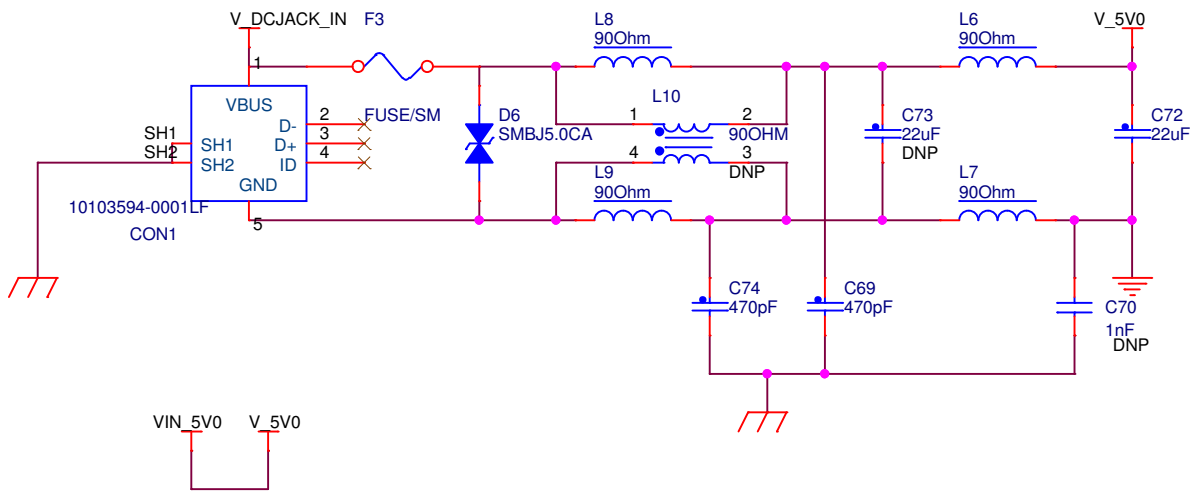

5V to 3.2v (base)

Notice assembly option -  
Base - LDO is used  
Pro - DC-DC is used

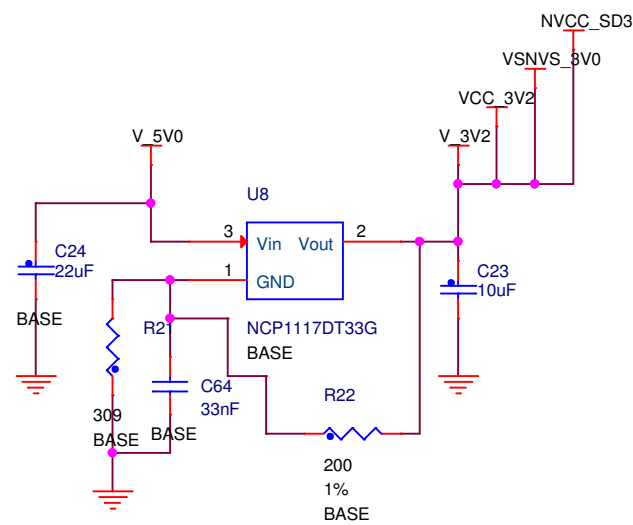

5V to 3.2v (pro)

C31 is assembled in both base and pro in order to provide more capacitance for the 3.2v rail

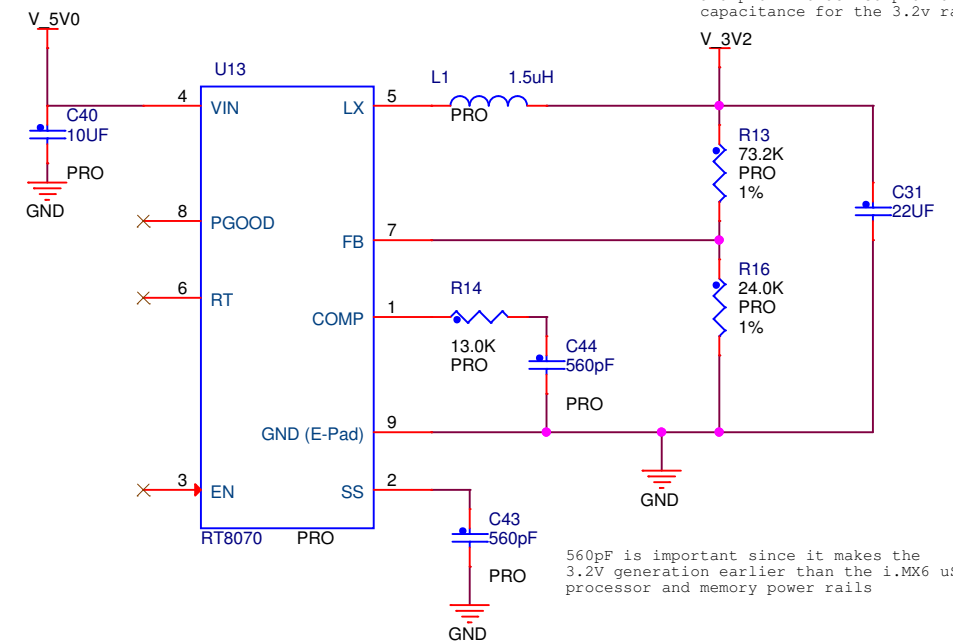

SDIO 3.2v / 1.8v switch circuitry

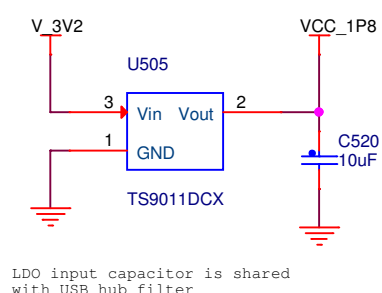

LDO input capacitor is shared with USB hub filter

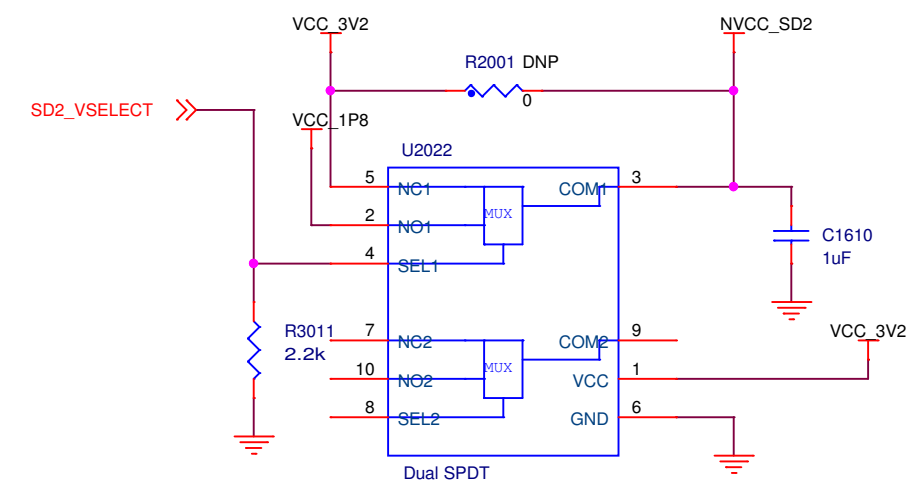

micro SD connectors (assembly option of push-push type and hinged type)  
Hinged type can not be assembled with mSata connector.

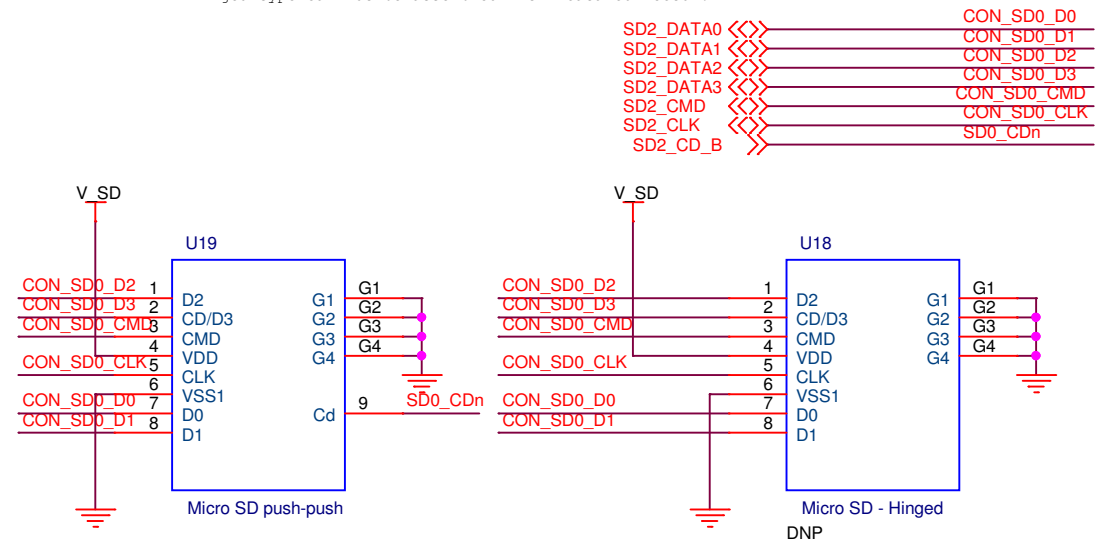

micro SD power on/off

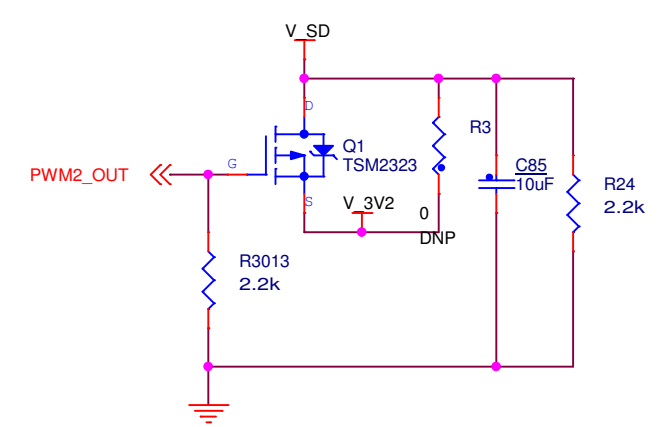

GPIO pin mapping -

Pin	GPIO
7	(1, 1)
11	(3, 9)
12	(3, 8)
13	(3, 7)
15	(3, 6)
16	(7, 2)
18	(7, 3)
22	(3, 3)

SPI and I2C can be also muxed to be GPIO

26 pin header

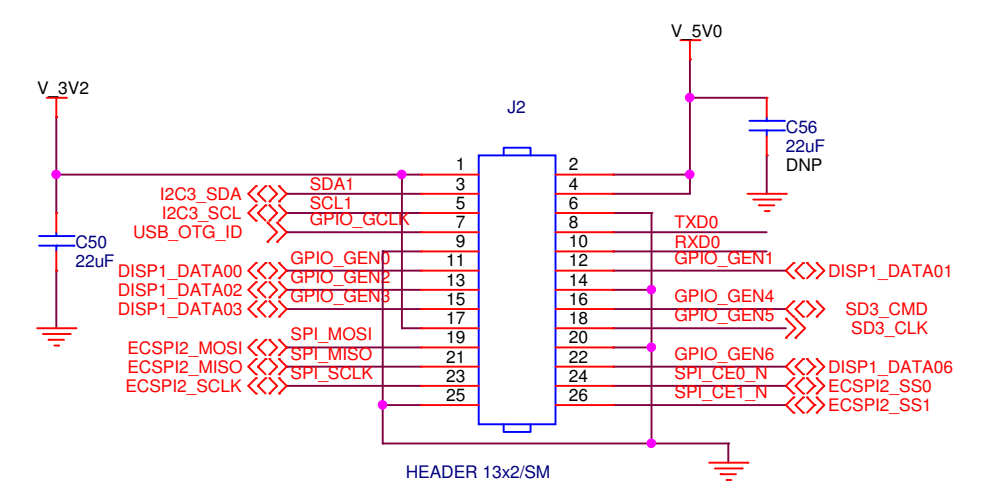

RESET button

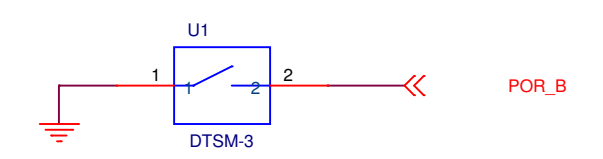

UART buffer (notice either U17 or U3 is assembled). R18 was initial 0 ohm and marked as DNP (to bypass the buffer in uart rx). But in case there is no pull up on the 26 pin header then the input of the buffer would float and sometimes generates noise in the uart rx. The workaround was to assemble R18 as 2.2kohm that forces a pullup in the 26 pin via i.MX6 pull up circuitry.

RJ45 Connector

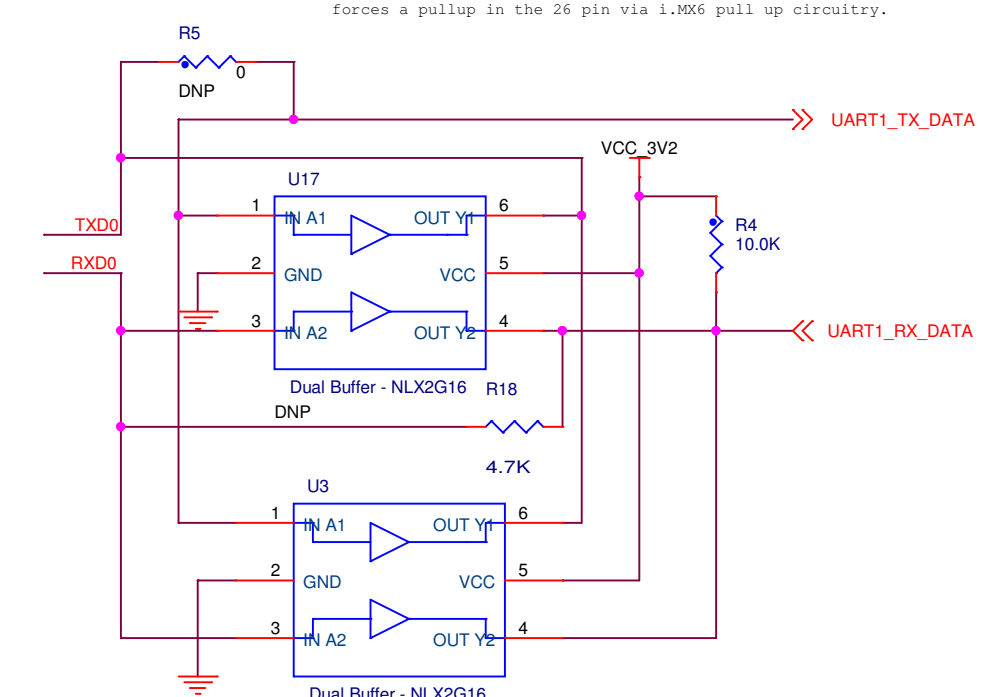
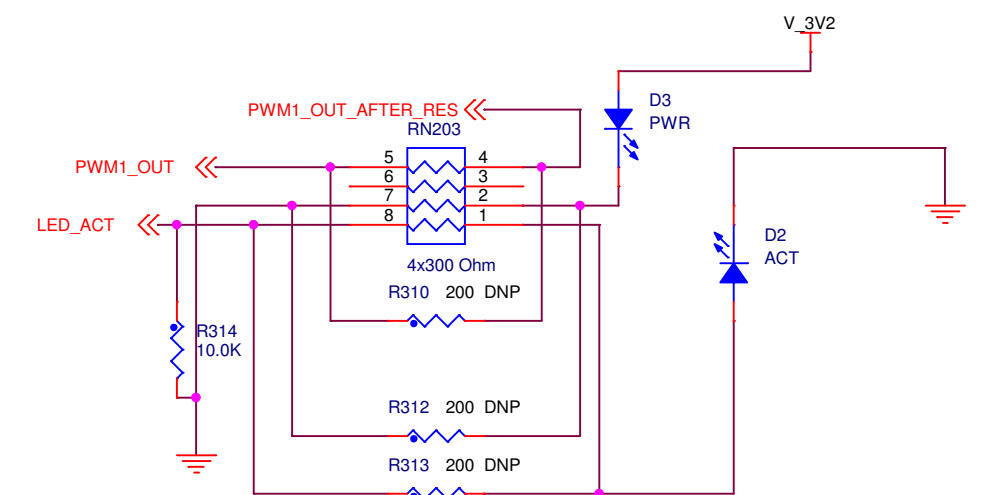
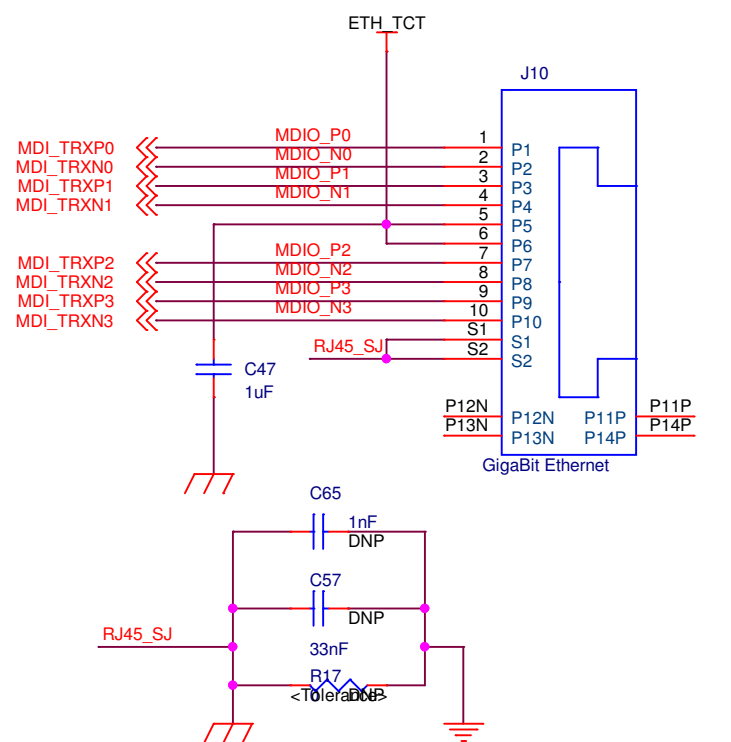



LVDS out

Since there isn't a standard LVDS out connector, this design uses the Freescale Sabre SD LVDS display.

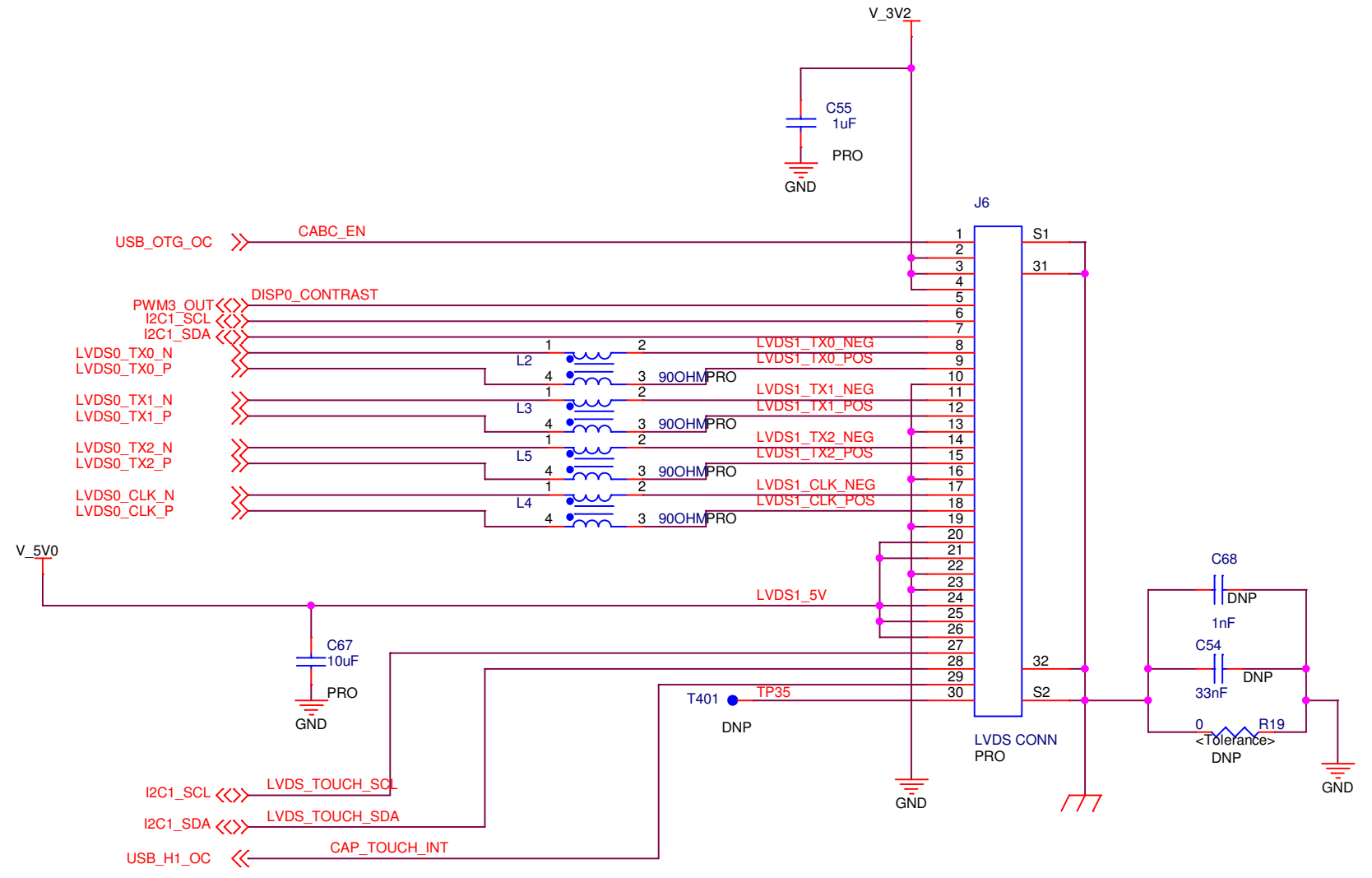
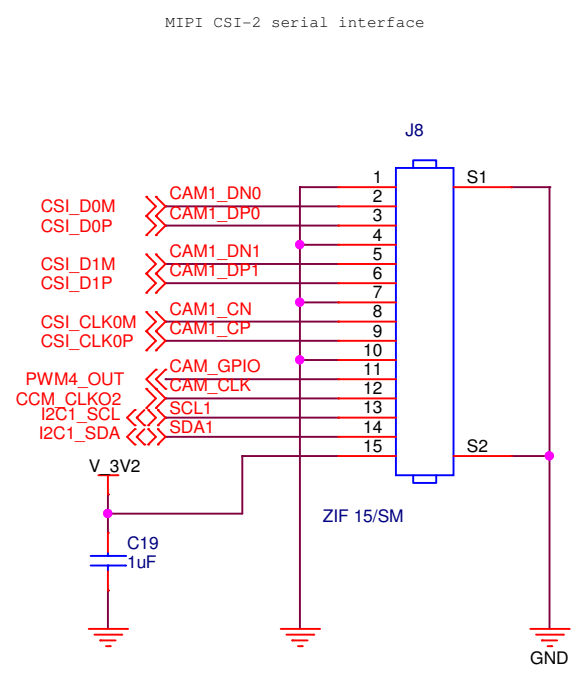

3.3v to 1.5v LDO (for mini pci express)

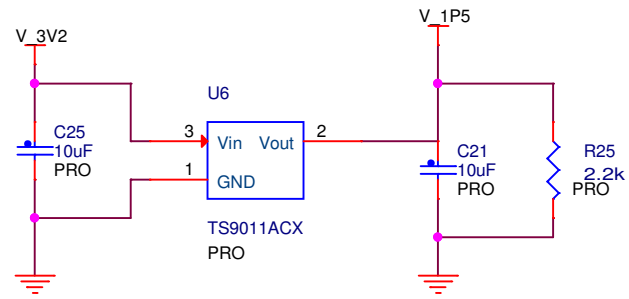

Half size mini PCI express with optional sim card

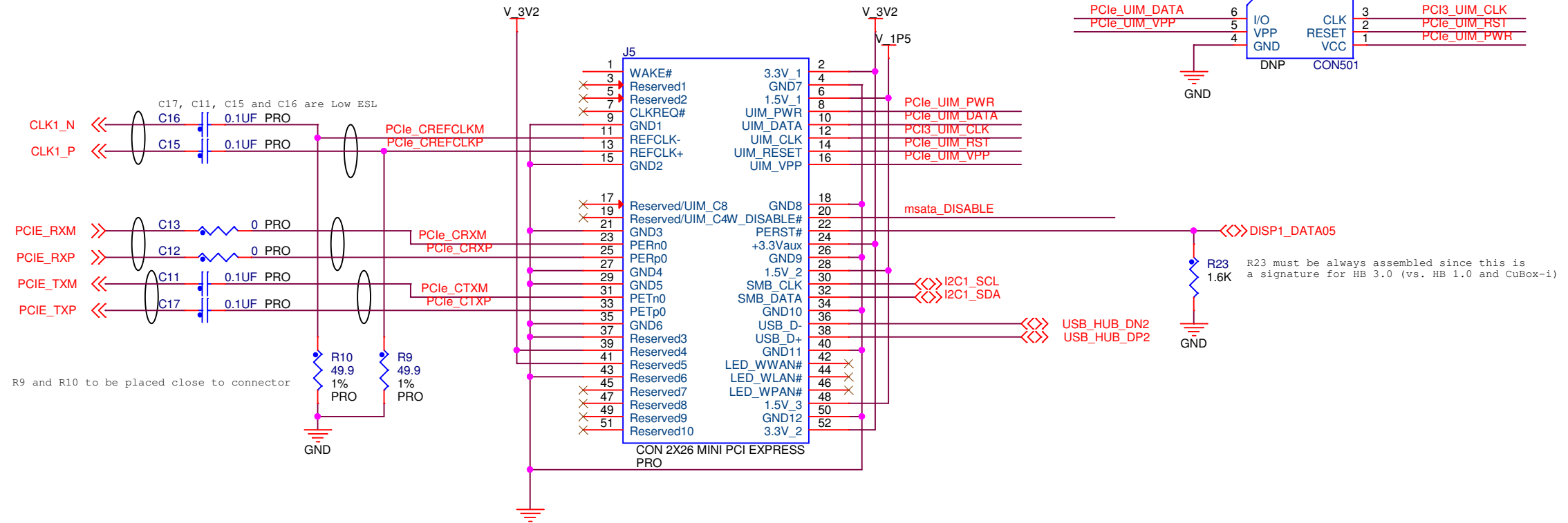

msata (pro and can be used by i.MX6D and i.MX6Q)

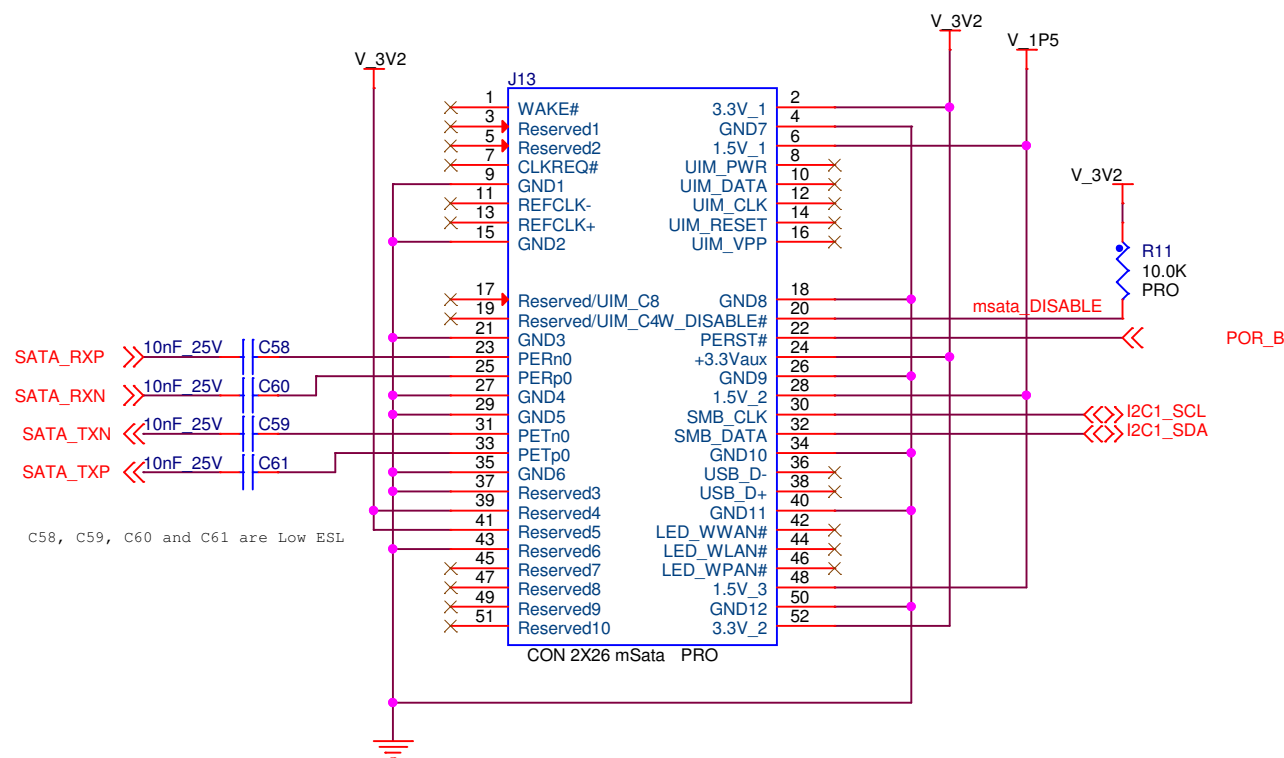

Infra red receiver

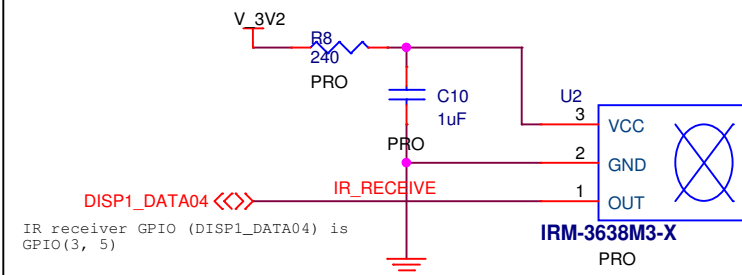

Real time clock (pro)

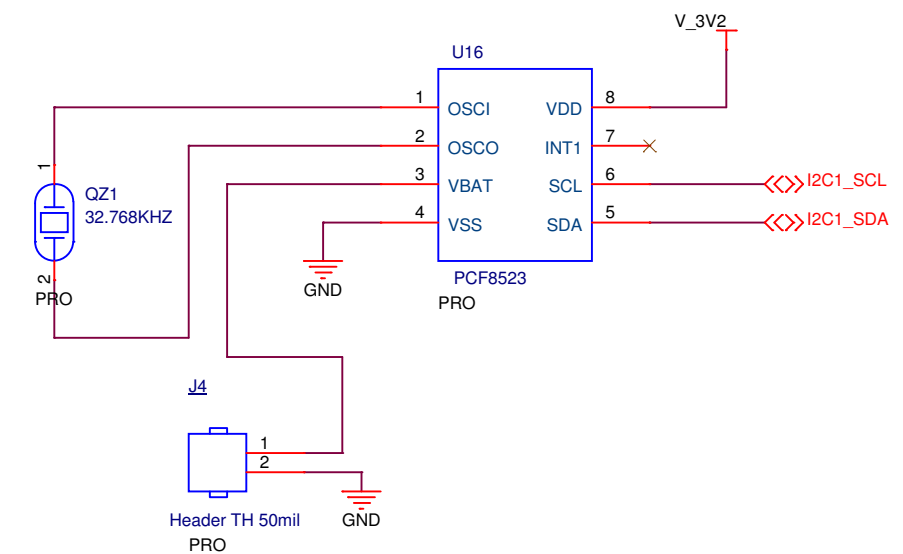

SolidRun Copyright (c) 2014 SolidRun Ltd. All Rights Reserved

Size	Title	Rev
A3	HummingBoard - mini pci, mSata, Infra red and RTC	3.0
Date:	Monday, June 23, 2014	Sheet 5 of 6

SGTL5000 audio codec

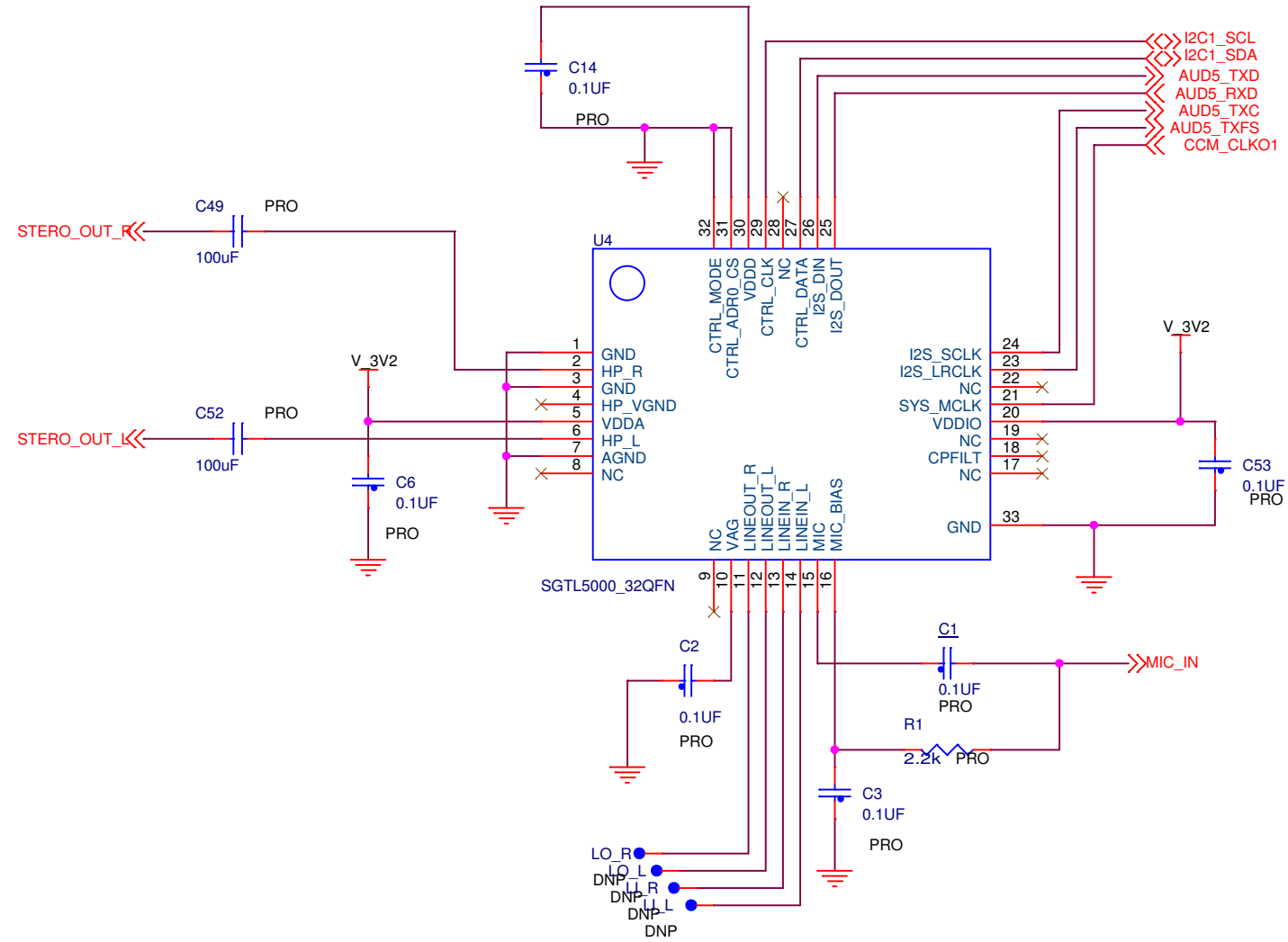

Audio in/out connector

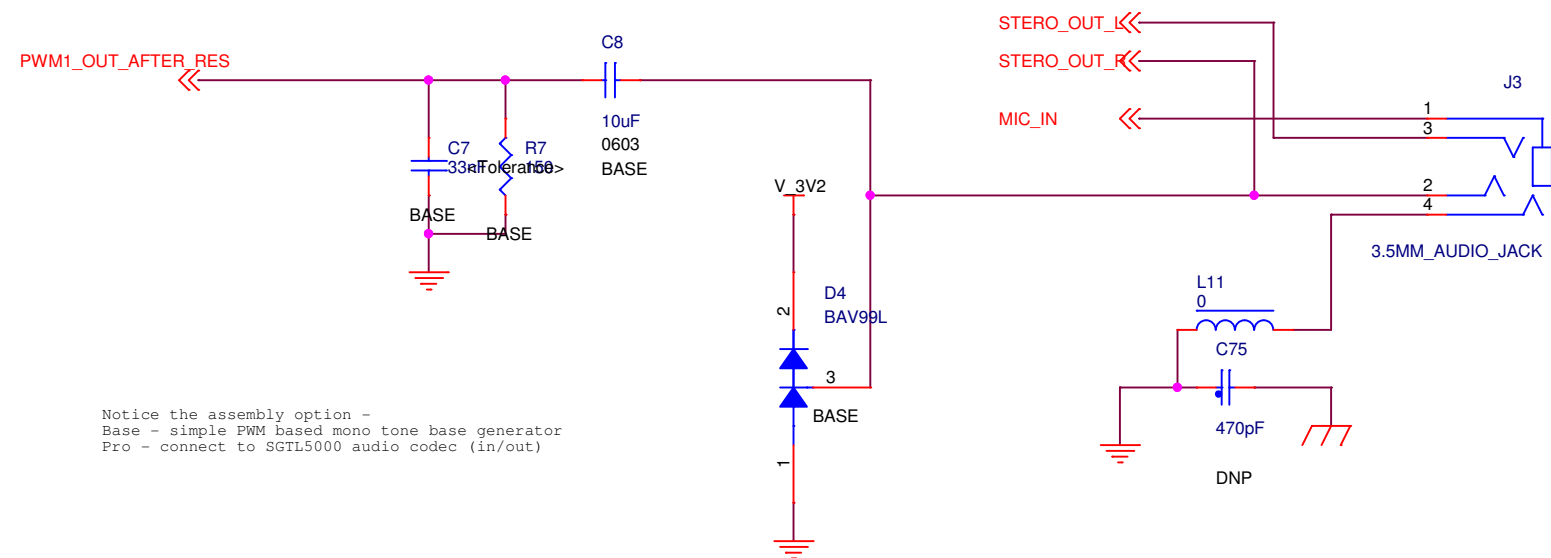

Notice the assembly option -  
 Base - simple PWM based mono tone base generator  
 Pro - connect to SGTL5000 audio codec (in/out)

Coax S/PDIF out

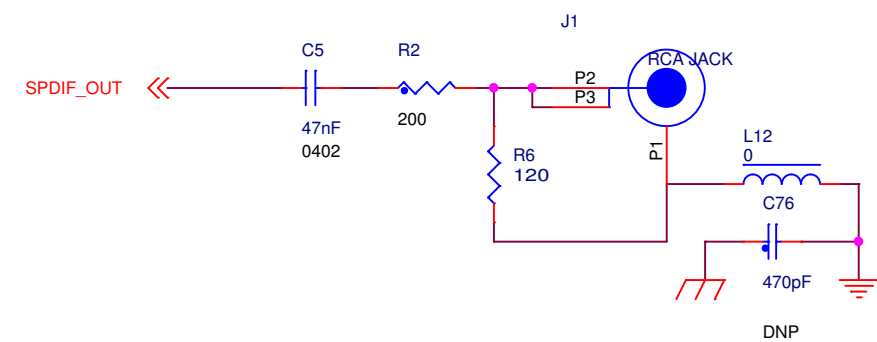

**SolidRun** Copyright (c) 2014 SolidRun Ltd.  
 All Rights Reserved

Size A3	Title HummingBoard - Analog and digital audio	Rev 3.0
Date: Monday, June 23, 2014	Sheet 6 of 6	