

## INTRODUCTION

KS0066U is a dot matrix LCD driver & controller LSI which is fabricated by low power CMOS technology. It can display 1 or 2 lines with the 5×8 dots format or 1 line with the 5×11 dots format.

## FUNCTIONS

- Character type dot matrix LCD driver & controller.
- Internal driver: 16 common and 40 segment signal output.
- Easy interface with 4-bit or 8-bit MPU.
- Display character pattern: 5×8 dots format (208 kinds) & 5×11 dots format (32 kinds).
- The Special character pattern is directly programmable by the Character Generator RAM.
- A customer character pattern is programmable by mask option.
- Programmable Driving Method by the same character font mask option: Display Waveform A-type and B-type
- It can drive a maximum at 80 characters by using the KS0065B or KS0063B externally.
- Various instruction functions.
- Built-in automatic power on reset.

80 QFP-1420C

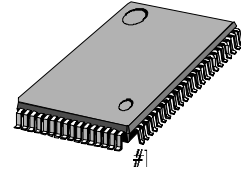

## FEATURES

- Internal Memory
  - Character Generator ROM (CGROM): 10,080 bits (204 characters×5×8 dots) & (32 characters×5×11 dots)
  - Character Generator RAM (CGRAM): 64×8 bits (8 characters×5×8 dots)
  - Display Data RAM (DDRAM): 80×8 bits (80 characters max.)
- Low power operation
  - Power supply voltage range (VDD): 2.7 to 5.5 V
  - LCD Drive voltage range (VDD-V5): 3.0 to 13.0 V
- CMOS process
- Programmable duty cycle: 1/8, 1/11, 1/16
- Internal oscillator with external resistor
- Low power consumption
- 80 QFP or bare chip available

BLOCK DIAGRAM

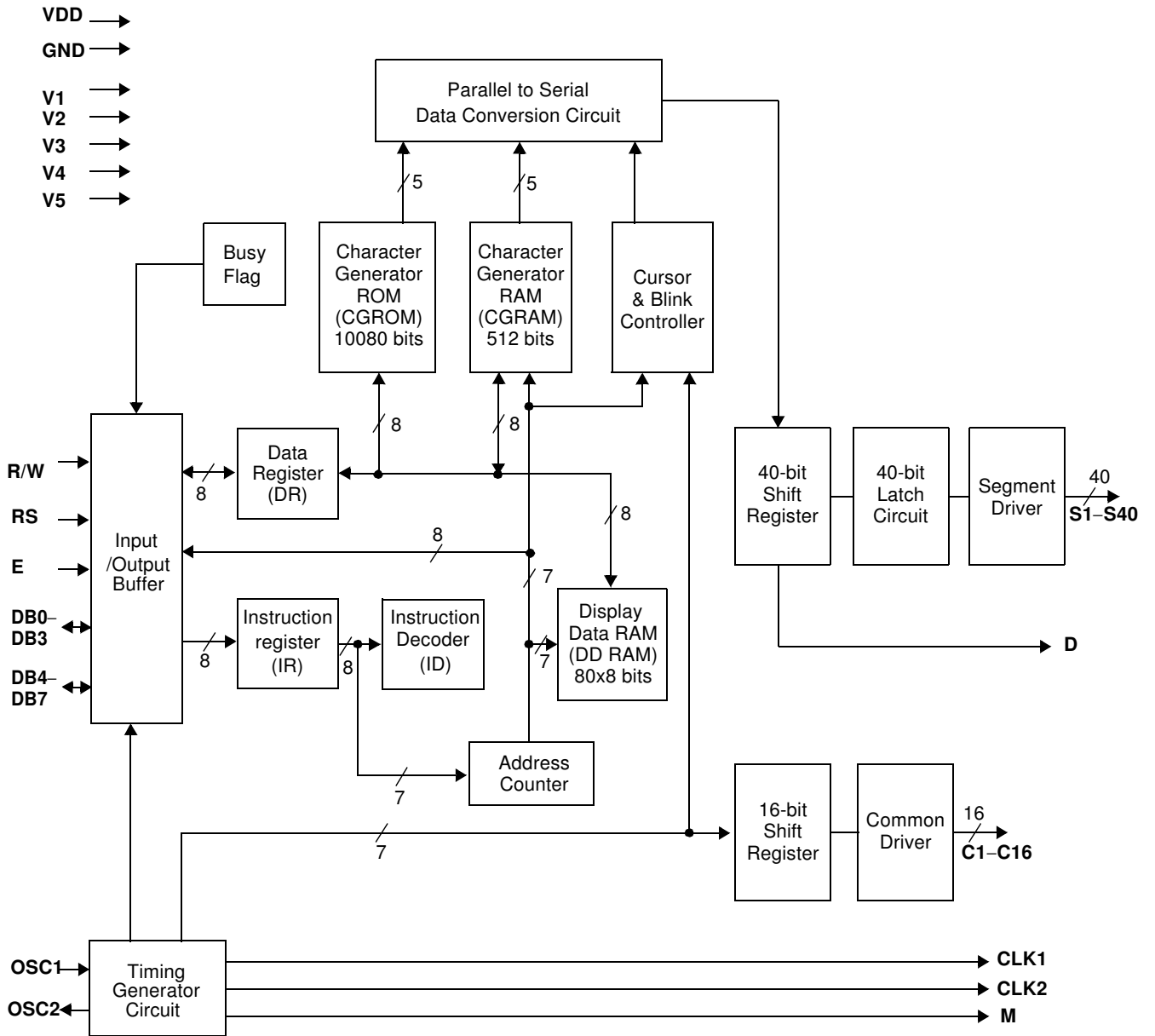

KS0066U

16COM / 40SEG DRIVER & CONTROLLER FOR DOT MATRIX LCD

PIN CONFIGURATION

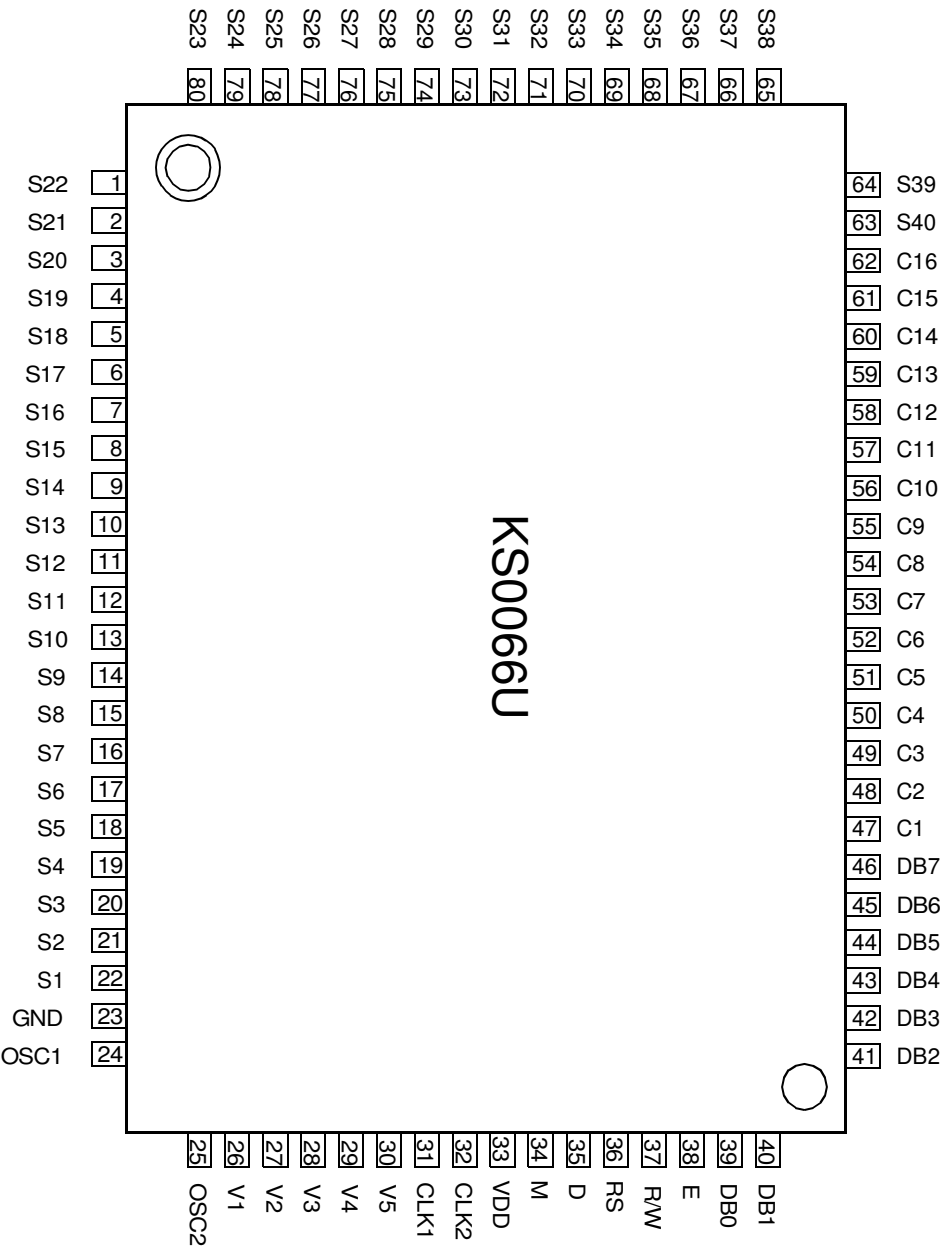

PAD DIAGRAM

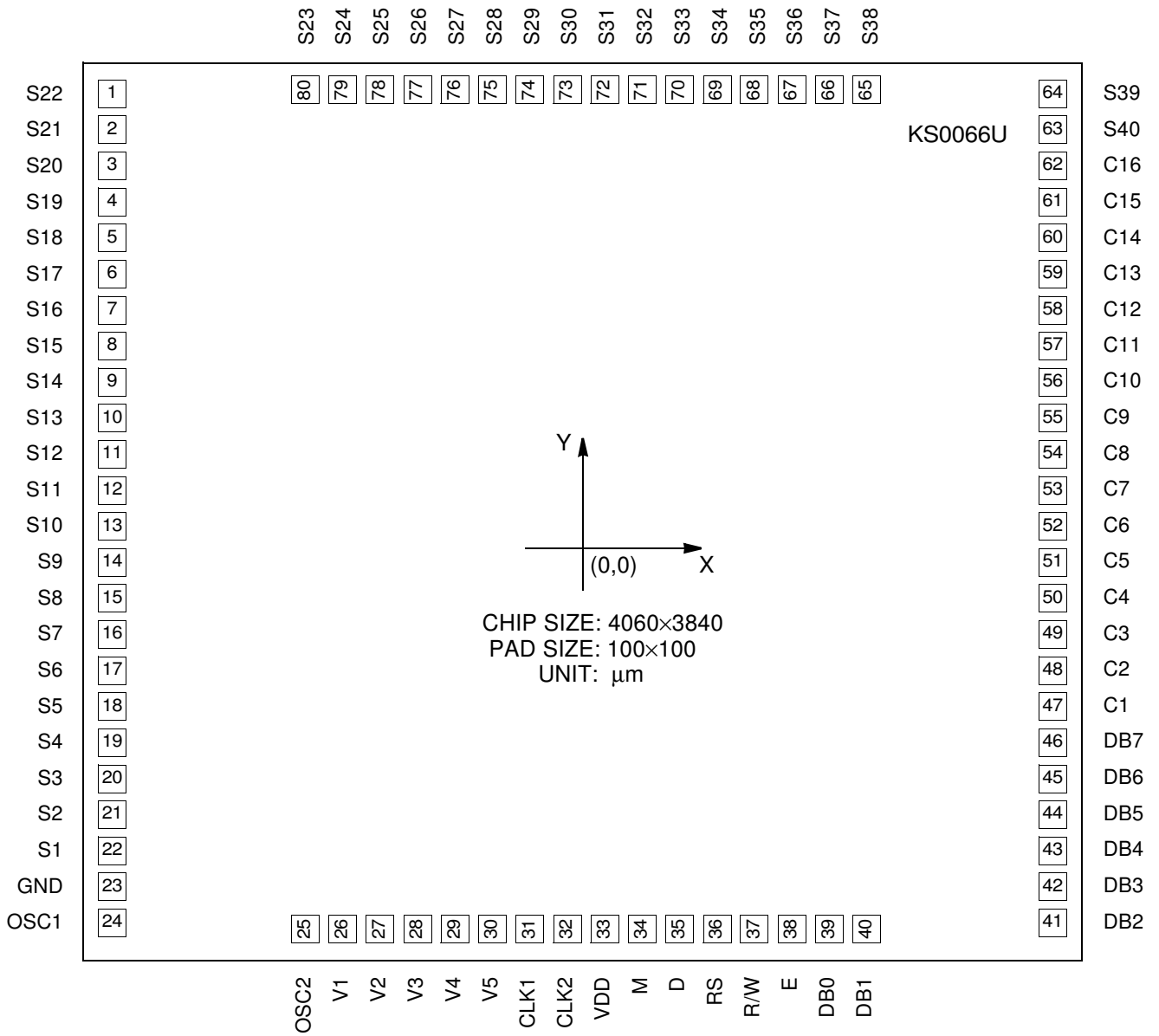

NOTE: "KS0066U" marking is to make the PAD No. 65 easy to find.

## PAD LOCATION

Table 1. Pad Location

(Unit:  $\mu\text{m}$ )

Pad No.	Pad Name	Coordinate		Pad No.	Pad Name	Coordinate		Pad No.	Pad Name	Coordinate		Pad No.	Pad Name	Coordinate	
		X	Y			X	Y			X	Y			X	Y
1	S22	-1864	1465	21	S2	-1864	-1034	41	DB2	1864	-1488	61	C15	1864	1085
2	S21	-1864	1340	22	S1	-1864	-1159	42	DB3	1864	-1362	62	C16	1864	1210
3	S20	-1864	1215	23	GND	-1864	-1285	43	DB4	1864	-1238	63	S40	1864	1341
4	S19	-1864	1090	24	OSC1	-1864	-1414	44	DB5	1864	-1112	64	S39	1864	1466
5	S18	-1864	965	25	OSC2	-1120	-1754	45	DB6	1864	-988	65	S38	886	1754
6	S17	-1864	840	26	V1	-970	-1754	46	DB7	1864	-862	66	S37	760	1754
7	S16	-1864	715	27	V2	-820	-1754	47	C1	1864	-665	67	S36	636	1754
8	S15	-1864	590	28	V3	-670	-1754	48	C2	1864	-540	68	S35	510	1754
9	S14	-1864	465	29	V4	-520	-1754	49	C3	1864	-415	69	S34	386	1754
10	S13	-1864	340	30	V5	-370	-1754	50	C4	1864	-290	70	S33	260	1754
11	S12	-1864	215	31	CLK1	-220	-1754	51	C5	1864	-165	71	S32	136	1754
12	S11	-1864	90	32	CLK2	-70	-1754	52	C6	1864	-40	72	S31	10	1754
13	S10	-1864	-35	33	VDD	80	-1754	53	C7	1864	85	73	S30	-114	1754
14	S9	-1864	-160	34	M	230	-1754	54	C8	1864	210	74	S29	-240	1754
15	S8	-1864	-285	35	D	380	-1754	55	C9	1864	335	75	S28	-364	1754
16	S7	-1864	-410	36	RS	518	-1754	56	C10	1864	460	76	S27	-490	1754
17	S6	-1864	-535	37	R/W	642	-1754	57	C11	1864	585	77	S26	-614	1754
18	S5	-1864	-660	38	E	768	-1754	58	C12	1864	710	78	S25	-740	1754
19	S4	-1864	-785	39	DB0	894	-1754	59	C13	1864	835	79	S24	-864	1754
20	S3	-1864	-910	40	DB1	1018	-1754	60	C14	1864	960	80	S23	-989	1754

## PIN DESCRIPTION

Table 2. Pin Description

Pin	Pin No.	I/O	Name	Description	Interface
VDD	33	-	Supply Voltage	Supply Voltage for logical circuit (+3V $\pm$ 10%, +5V $\pm$ 10%)	Power Supply
GND	23			Ground (0V)	
V1-V5	26-30			Bias voltage level for LCD driving	
S1-S40	1-22, 63-80	O	Segment output	Segment signal output for LCD drive	LCD
C1-C16	47-62	O	Common output	Common signal output for LCD drive	LCD
OSC1	24	I	Oscillator	Oscillator. When using internal oscillator, connect external Rf resistor. If external clock is used, connect it to OSC1.	External resistor/oscillator (OSC1)
OSC2	25	O	Oscillator		
CLK1	31	O	Extension driver Latch clock	Extension driver latch clock	Extension driver
CLK2	32	O	Extension driver Shift clock	Extension driver shift clock	
M	34	O	Alternated signal for LCD driver output	Outputs the alternating signal to convert LCD driver waveform to AC.	Extension driver
D	35	O	Display data interface	Outputs extension driver data (the 41st dot's data)	Extension driver
RS	36	I	Register select	Used as register selection input. When RS = 'High', Data register is selected. When RS = 'Low', Instruction register is selected.	MPU
R/W	37	I	Read/Write	Used as read/write selection input. When RW = 'High', read operation. When RW = 'Low', write operation.	MPU
E	38	I	Read/Write enable	Used as read/write enable signal.	MPU
DB0-DB3	39-42	I/O	Data bus 0-7	In 8-bit bus mode, used as low order bidirectional data bus. In 4-bit bus mode, open these pins.	MPU
DB4-DB7	43-46			In 8-bit bus mode, used as high order bidirectional data bus. In 4-bit bus mode, used as both high and low order. DB7 used for Busy Flag output.	MPU

## FUNCTION DESCRIPTION

### System Interface

This chip has both kinds of interface type with MPU: 4-bit bus and 8-bit bus. 4-bit bus and 8-bit bus are selected by the DL bit in the instruction register.

During read or write operation, two 8-bit registers are used. One is the data register (DR), and the other is the instruction register (IR).

The data register (DR) is used as a temporary data storage place for being written into or read from DDRAM/CGRAM. The target RAM is selected by RAM address setting instruction. Each internal operation, reading from or writing into RAM, is done automatically. Thus, after MPU reads DR data, the data in the next DDRAM/CGRAM address is transferred into DR automatically. Also, after MPU writes data to DR, the data in DR is transferred into DDRAM/CGRAM automatically.

The Instruction register(IR) is used only to store instruction codes transferred from MPU. MPU cannot use it to read instruction data.

To select a register, you can use RS input pin in 4-bit/8-bit bus mode.

**Table 3. Various kinds of Operations according to RS and R/W bits**

RS	R/W	Operation
L	L	Instruction Write operation (MPU writes Instruction code into IR)
L	H	Read Busy flag(DB7) and address counter (DB0 to DB6)
H	L	Data Write operation (MPU writes data into DR)
H	H	Data Read operation (MPU reads data from DR)

### Busy Flag (BF)

BF = "High", indicates that the internal operation is being processed. So during this time the next instruction cannot be accepted. BF can be read through DB7 port when RS = "Low" and R/W = "High" (Read Instruction Operation). Before executing the next instruction, be sure that BF is not "High".

### Address Counter (AC)

The address Counter (AC) stores DDRAM/CGRAM addresses, transferred from IR. After writing into (reading from) DDRAM/CGRAM, AC is automatically increased (decreased) by 1. When RS = "Low" and R/W = "High", AC can be read through ports DB0 to DB6.

**Display Data RAM (DDRAM)**

DDRAM stores display data of maximum 80×8 bits (80 characters).  
 DDRAM address is set in the address counter(AC) as a hexadecimal number (Refer to Fig-1.)

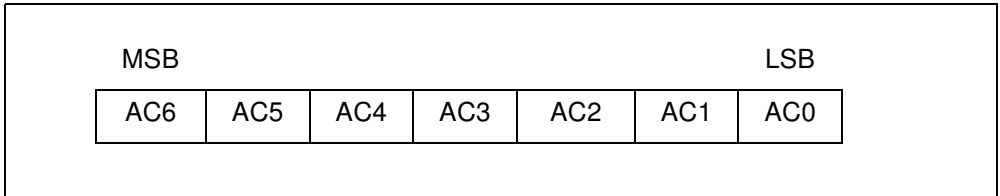

**Figure 1 . DDRAM Address**

1) 1-line display

In case of 1-line display, the address range of DDRAM is 00H–4FH.  
 An extension driver will be used. Fig-2 shows the example with 40 segment extension driver added.

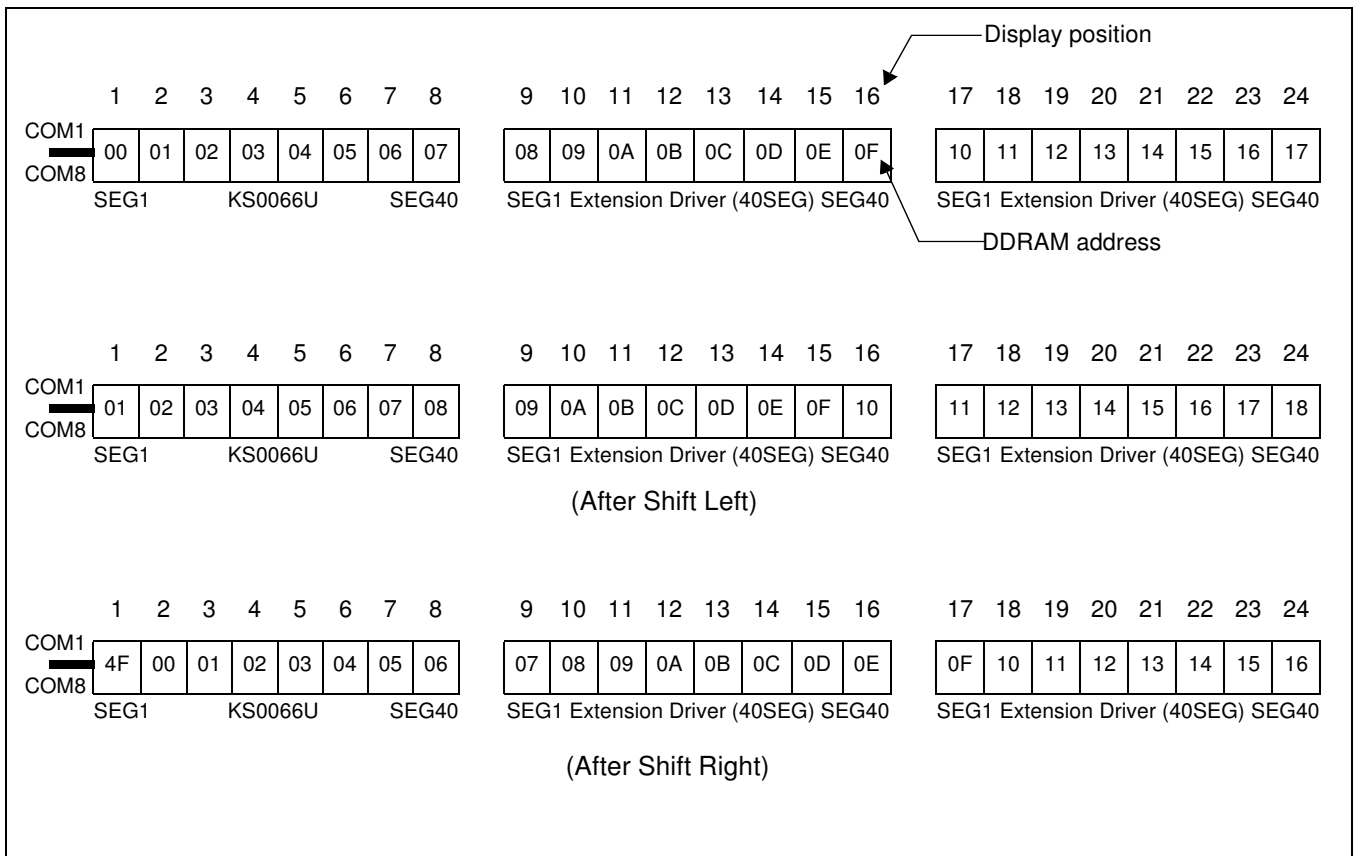

**Figure 2 . 1-line × 24 char. display with 40 SEG. extension driver**

2) 2-line display

In case of 2-line display, the address range of DDRAM is 00H-27H and 40H-67H.  
 An extension driver will be used. Fig-3 shows the example with 40 segment extension driver added.

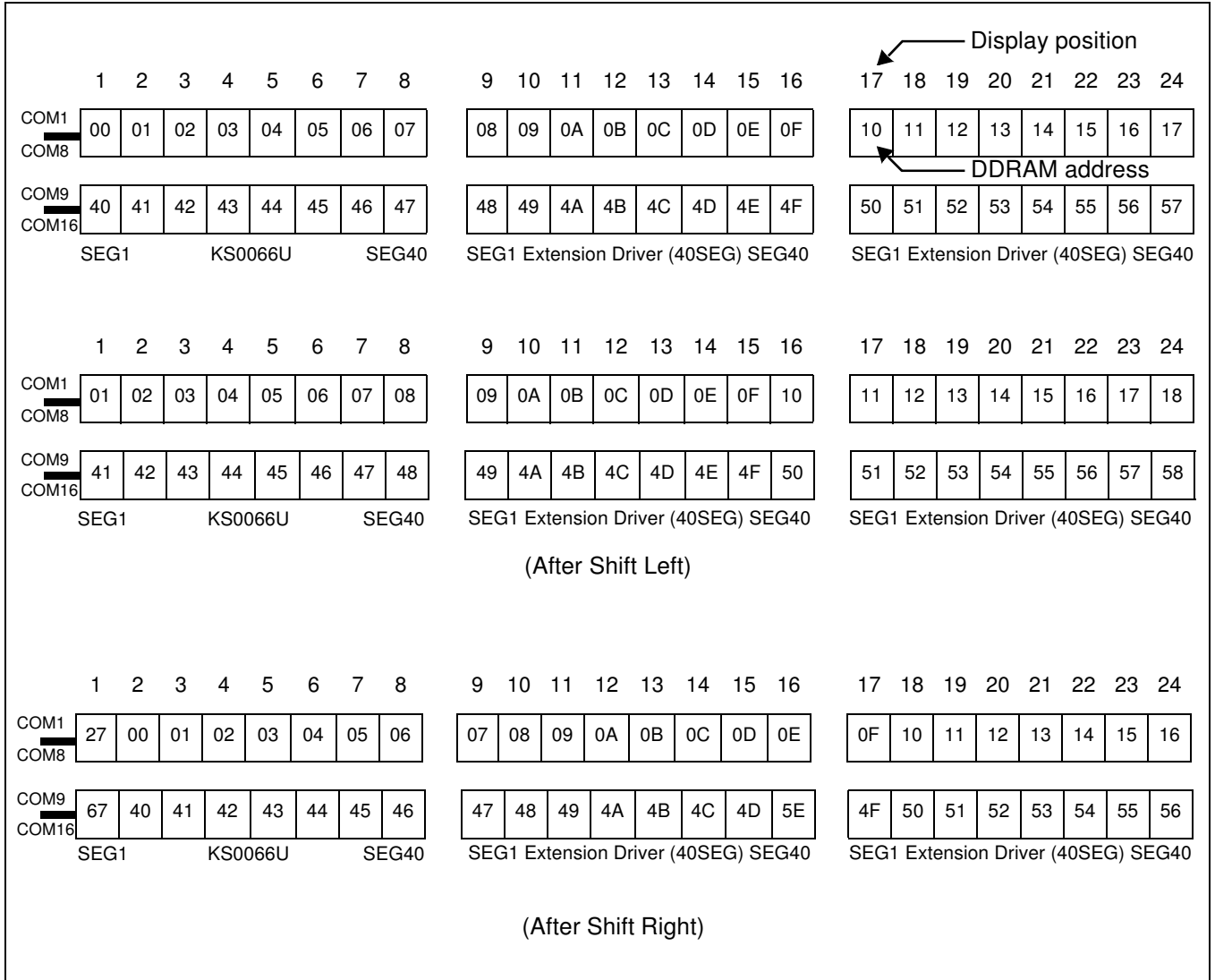

Figure 3 . 2-line x 24 char. display with 40 SEG. extension driver

**CGROM(Character Generator ROM)**

CGROM has a 5×8 dots 204 characters pattern and a 5×11 dots 32 characters pattern (Refer to Table 4).  
CGROM has 204 character patterns of 5×8 dots, and 32 character patterns of 5×11 dots.

**CGRAM(Character Generator RAM)**

CGRAM has up to 5×8 dots 8 characters.  
By writing font data to CGRAM, user defined characters can be used (Refer to Table 5)

**Timing Generation Circuit**

Timing generation circuit generates clock signals for the internal operations.

**LCD Driver Circuit**

LCD Driver circuit has 16 common and 40 segment signals for LCD driving.  
Data from CGRAM/CGROM is transferred to a 40-bit segment latch serially, and then is stored to 40-bit shift latch.  
When each common is selected by 16-bit common register, segment data is also output through segment driver from a 40-bit segment latch.  
In case of 1-line display mode, COM1 to COM8 have 1/8 duty or COM1 to COM11 have 1/11 duty,  
and in 2-line mode, COM1 to COM16 have a 1/16 duty ratio.

**Cursor/Blink Control Circuit**

It controls the cursor/blink ON/OFF at cursor position.

Table 4. CGROM Character Code Table

Table 5. Relationship between Character Code (DDRAM) and Character Pattern (CGRAM)

Character Code (DDRAM data)								CGRAM Address				CGRAM Data								Pattern number																									
D7	D6	D5	D4	D3	D2	D1	D0	A5	A4	A3	A2	A1	A0	P7	P6	P5	P4	P3	P2		P1	P0																							
0	0	0	0	×	0	0	0	0	0	0	0	0	0	×	×	×	0	1	1	1	0	pattern 1																							
											0	0	1				1	0	0	0	1																								
											0	1	0				1	0	0	0	1																								
											0	1	1				1	1	1	1	1																								
											1	0	0				1	0	0	0	1																								
											1	0	1				1	0	0	0	1																								
											1	1	0				1	0	0	0	1																								
											1	1	1				0	0	0	0	0																								
0	0	0	0	×	1	1	1	0	0	0	0	0	0	×	×	×	1	0	0	0	1	pattern 8																							
											0	0	1				1	0	0	0	1																								
											0	1	0				1	0	0	0	1																								
											0	1	1				1	1	1	1	1																								
											1	0	0				1	0	0	0	1																								
											1	0	1				1	0	0	0	1																								
											1	1	0				1	0	0	0	1																								
											1	1	1				0	0	0	0	0																								

**INSTRUCTION DESCRIPTION**

**Outline**

To overcome the speed difference between the internal clock of KS0066U and the MPU clock, KS0066U performs internal operations by storing control informations to IR or DR. The internal operation is determined according to the signal from MPU, composed of read/write and data bus (Refer to Table 7).

Instructions can be divided largely into four groups:

- 1) KS0066U function set instructions (set display methods, set data length, etc.)
- 2) address set instructions to internal RAM
- 3) data transfer instructions with internal RAM
- 4) others

The address of the internal RAM is automatically increased or decreased by 1.

Note: During internal operation, Busy Flag (DB7) is read 'High'.

Busy Flag check must be preceded by the next instruction.

When an MPU program with checking the Busy Flag (DB7) is made, it must be necessary 1/2 fosc for executing the next instruction by the falling edge of the 'E' signal after the Busy Flag (DB7) goes to 'Low'.

**Contents**

1) Clear Display

RS	R/W	DB7	DB6	DB5	DB4	DB3	DB2	DB1	DB0
0	0	0	0	0	0	0	0	0	1

Clear all the display data by writing "20H" (space code) to all DDRAM address, and set DDRAM address to "00H" into AC (address counter).

Return cursor to the original status, namely, bring the cursor to the left edge on the first line of the display. Make the entry mode increment (I/D = 'High').

2) Return Home

RS	R/W	DB7	DB6	DB5	DB4	DB3	DB2	DB1	DB0
0	0	0	0	0	0	0	0	1	-

\* "-" : dont care

Return Home is cursor return home instruction.

Set DDRAM address to "00H" into the address counter.

Return cursor to its original site and return display to its original status, if shifted.

Contents of DDRAM does not change.

## 3) Entry Mode Set

RS	R/W	DB7	DB6	DB5	DB4	DB3	DB2	DB1	DB0
0	0	0	0	0	0	0	1	I/D	SH

Set the moving direction of cursor and display.

**I/D: Increment / decrement of DDRAM address (cursor or blink)**

When I/D = 'High', cursor/blink moves to right and DDRAM address is increased by 1.

When I/D = 'Low', cursor/blink moves to left and DDRAM address is decreased by 1.

\* CGRAM operates the same way as DDRAM, when reading from or writing to CGRAM.

**SH: Shift of entire display**

When DDRAM read (CGRAM read/write) operation or SH = 'Low', shifting of entire display is not performed.

If SH = 'High' and DDRAM write operation, shift of entire display is performed according to I/D value

(I/D = 'High': shift left, I/D = 'Low': shift right).

## 4) Display ON/OFF Control

RS	R/W	DB7	DB6	DB5	DB4	DB3	DB2	DB1	DB0
0	0	0	0	0	0	1	D	C	B

Control display/cursor/blink ON/OFF 1 bit register.

**D: Display ON/OFF control bit**

When D = 'High', entire display is turned on.

When D = 'Low', display is turned off, but display data remains in DDRAM.

**C: Cursor ON/OFF control bit**

When C = 'High', cursor is turned on.

When C = 'Low', cursor is disappeared in current display, but I/D register preserves its data.

**B: Cursor Blink ON/OFF control bit**

When B = 'High', cursor blink is on, which performs alternately between all the 'High' data and display characters at the cursor position.

When B = 'Low', blink is off.

## 5) Cursor or Display Shift

RS	R/W	DB7	DB6	DB5	DB4	DB3	DB2	DB1	DB0
0	0	0	0	0	1	S/C	R/L	-	-

Shifting of right/left cursor position or display without writing or reading of display data.

This instruction is used to correct or search display data.(Refer to Table 6)

During 2-line mode display, cursor moves to the 2nd line after the 40th digit of the 1st line.

Note that display shift is performed simultaneously in all the lines.

When displayed data is shifted repeatedly, each line is shifted individually.

When display shift is performed, the contents of the address counter are not changed.

**Table 6. Shift Patterns According to S/C and R/L Bits**

S/C	R/L	Operation
0	0	Shift cursor to the left, AC is decreased by 1
0	1	Shift cursor to the right, AC is increased by 1
1	0	Shift all the display to the left, cursor moves according to the display
1	1	Shift all the display to the right, cursor moves according to the display

## 6) Function Set

RS	R/W	DB7	DB6	DB5	DB4	DB3	DB2	DB1	DB0
0	0	0	0	1	DL	N	F	-	-

**DL: Interface data length control bit**

When DL = 'High', it means 8-bit bus mode with MPU.

When DL = 'Low', it means 4-bit bus mode with MPU. Hence, DL is a signal to select 8-bit or 4-bit bus mode.

When 4-bit bus mode, it needs to transfer 4-bit data twice.

**N: Display line number control bit**

When N = 'Low', 1-line display mode is set.

When N = 'High', 2-line display mode is set.

**F: Display font type control bit**

When F = 'Low', 5 × 8 dots format display mode is set.

When F = 'High', 5 × 11 dots format display mode.

## 7) Set CGRAM Address

RS	R/W	DB7	DB6	DB5	DB4	DB3	DB2	DB1	DB0
0	0	0	1	AC5	AC4	AC3	AC2	AC1	AC0

Set CGRAM address to AC.

This instruction makes CGRAM data available from MPU.

## 8) Set DDRAM Address

RS	R/W	DB7	DB6	DB5	DB4	DB3	DB2	DB1	DB0
0	0	1	AC6	AC5	AC4	AC3	AC2	AC1	AC0

Set DDRAM address to AC.

This instruction makes DDRAM data available from MPU.

When 1-line display mode (N = Low), DDRAM address is from '00H" to "4FH".

In 2-line display mode (N = High), DDRAM address in the 1st line is from "00H" to "27H", and DDRAM address in the 2nd line is from "40H" to "67H".

## 9) Read Busy Flag &amp; Address

RS	R/W	DB7	DB6	DB5	DB4	DB3	DB2	DB1	DB0
0	1	BF	AC6	AC5	AC4	AC3	AC2	AC1	AC0

This instruction shows whether KS0066U is in internal operation or not.

If the resultant BF is 'High', internal operation is in progress and should wait until BF is to be Low, which by then the next instruction can be performed. In this instruction you can also read the value of the address counter.

## 10) Write data to RAM

RS	R/W	DB7	DB6	DB5	DB4	DB3	DB2	DB1	DB0
1	0	D7	D6	D5	D4	D3	D2	D1	D0

Write binary 8-bit data to DDRAM/CGRAM.

The selection of RAM from DDRAM, and CGRAM, is set by the previous address set instruction (DRAM address set, CGRAM address set).

RAM set instruction can also determine the AC direction to RAM.

After write operation, the address is automatically increased/decreased by 1, according to the entry mode.

## 11) Read data from RAM

RS	R/W	DB7	DB6	DB5	DB4	DB3	DB2	DB1	DB0
1	1	D7	D6	D5	D4	D3	D2	D1	D0

Read binary 8-bit data from DDRAM/CGRAM.

The selection of RAM is set by the previous address set instruction. If the address set instruction of RAM is not performed before this instruction, the data that has been read first is invalid, as the direction of AC is not Yet determined. If RAM data is read several times without RAM address instructions set before read operation, the correct RAM data can be obtained from the second. But the first data would be incorrect, as there is no time margin to transfer RAM data.

In case of DDRAM read operation, cursor shift instruction plays the same role as DDRAM address set instruction, it also transfers RAM data to output data register.

After read operation, address counter is automatically increased/decreased by 1 according to the entry mode.

After CGRAM read operation, display shift may not be executed correctly.

NOTE: In case of RAM write operation, AC is increased/decreased by 1 as in read operation.

At this time, AC indicates the next address position, but only the previous data can be read by the read instruction.

Table 7. Instruction Table

Instruction	Instruction Code										Description	Execution time (fosc=270 kHz)	
	RS	R/W	DB7	DB6	DB5	DB4	DB3	DB2	DB1	DB0			
Clear Display	0	0	0	0	0	0	0	0	0	0	1	Write '20H" to DDRAM and set DDRAM address to '00H" from AC	1.53 ms
Return Home	0	0	0	0	0	0	0	0	0	1	-	Set DDRAM address to '00H" from AC and return cursor to its original position if shifted. The contents of DDRAM are not changed.	1.53 ms
Entry Mode Set	0	0	0	0	0	0	0	0	1	I/D	SH	Assign cursor moving direction and enable the shift of entire display.	39 μs
Display ON/OFF Control	0	0	0	0	0	0	0	1	D	C	B	Set display(D), cursor(C), and blinking of cursor(B) on/off control bit.	39 μs
Cursor or Display Shift	0	0	0	0	0	0	1	S/C	R/L	-	-	Set cursor moving and display shift control bit, and the direction, without changing of DDRAM data.	39 μs
Function Set	0	0	0	0	0	1	DL	N	F	-	-	Set interface data length (DL: 8-bit/4-bit), numbers of display line (N: 2-line/1-line) and, display font type (F:5×11 dots/5×8 dots)	39 μs
Set CGRAM Address	0	0	0	1	AC5	AC4	AC3	AC2	AC1	AC0		Set CGRAM address in address counter.	39 μs
Set DDRAM Address	0	0	1	AC6	AC5	AC4	AC3	AC2	AC1	AC0		Set DDRAM address in address counter.	39 μs
Read Busy Flag and Address	0	1	BF	AC6	AC5	AC4	AC3	AC2	AC1	AC0		Whether during internal operation or not can be known by reading BF. The contents of address counter can also be read.	0 μs
Write Data to RAM	1	0	D7	D6	D5	D4	D3	D2	D1	D0		Write data into internal RAM (DDRAM/CGRAM).	43 μs
Read Data from RAM	1	1	D7	D6	D5	D4	D3	D2	D1	D0		Read data from internal RAM (DDRAM/CGRAM).	43 μs

\* "-": dont care

NOTE: When an MPU program with checking the Busy Flag(DB7) is made, it must be necessary 1/2Fosc is necessary for executing the next instruction by the falling edge of the 'E' signal after the Busy Flag (DB7) goes to 'Low'.

**INTERFACE WITH MPU**

1) Interface with 8-bit MPU

When interfacing data length are 8-bit, transfer is performed at a time through 8 ports, from DB0 to DB7. Example of timing sequence is shown below.

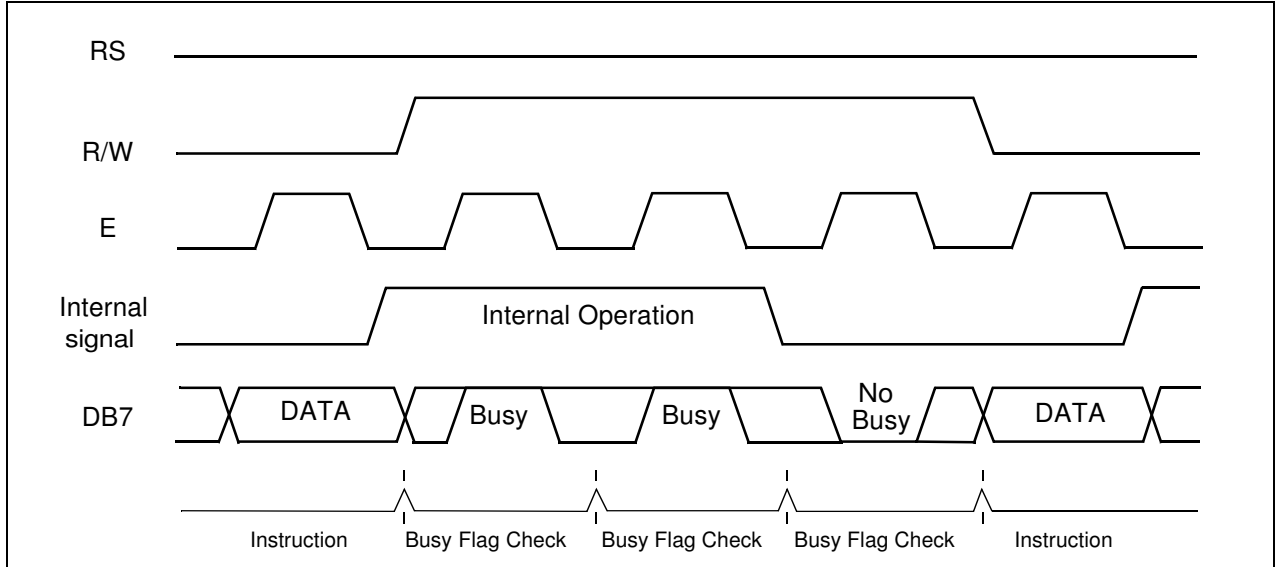

**Figure 4 . Example of 8-bit Bus Mode Timing Diagram**

2) Interface with 4-bit MPU

When interfacing data length are 4-bit, only 4 ports, from DB4 to DB7, are used as data bus. At First, the higher 4-bit (in case of 8-bit bus mode, the contents of DB4 - DB7), and then the lower 4-bit (in case of 8-bit bus mode, the contents of DB0 - DB3) are transferred. So transfer is performed twice. Busy Flag outputs 'High' after the second transfer is ended. Example of timing sequence is shown below.

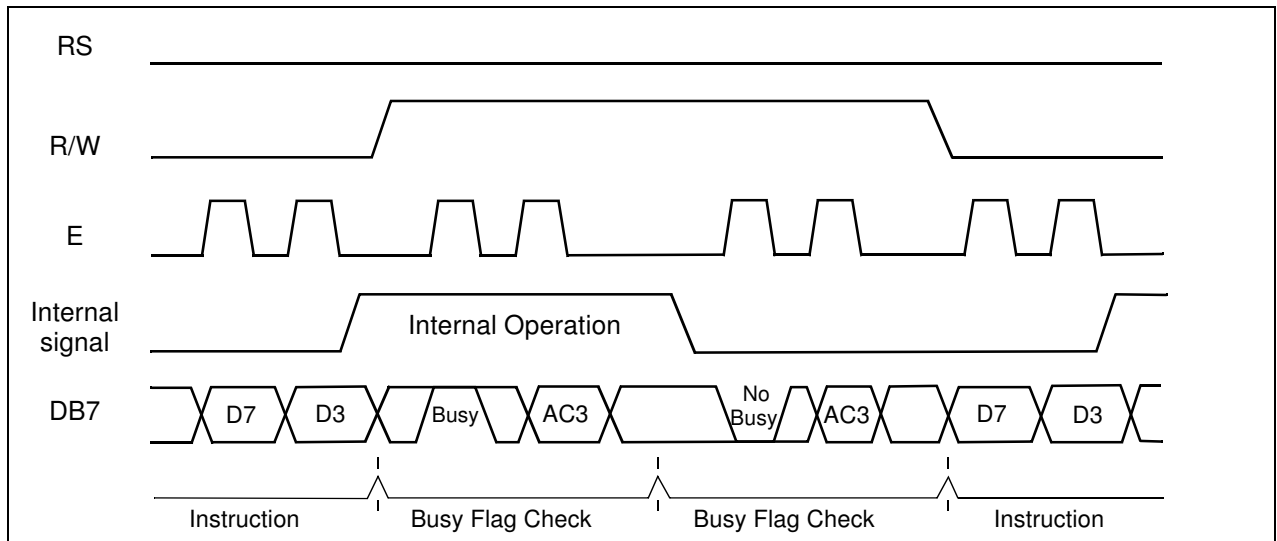

**Figure 5 . Example of 4-bit Bus Mode Timing Diagram**

APPLICATION INFORMATION ACCORDING TO LCD PANEL

1) LCD Panel: 8 characters  $\times$  1-line format (5 $\times$ 7 dots + 1 cursor line, 1/4 bias, 1/8 duty)

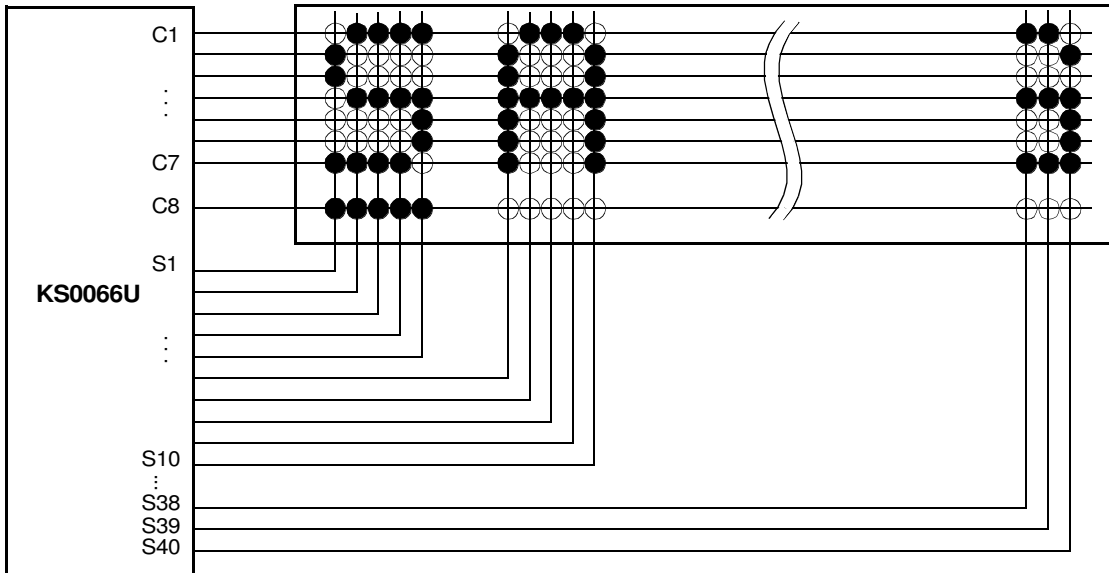

2) LCD Panel: 8 characters  $\times$  1-line format (5 $\times$ 10 dots + 1 cursor line, 1/4 bias, 1/11 duty)

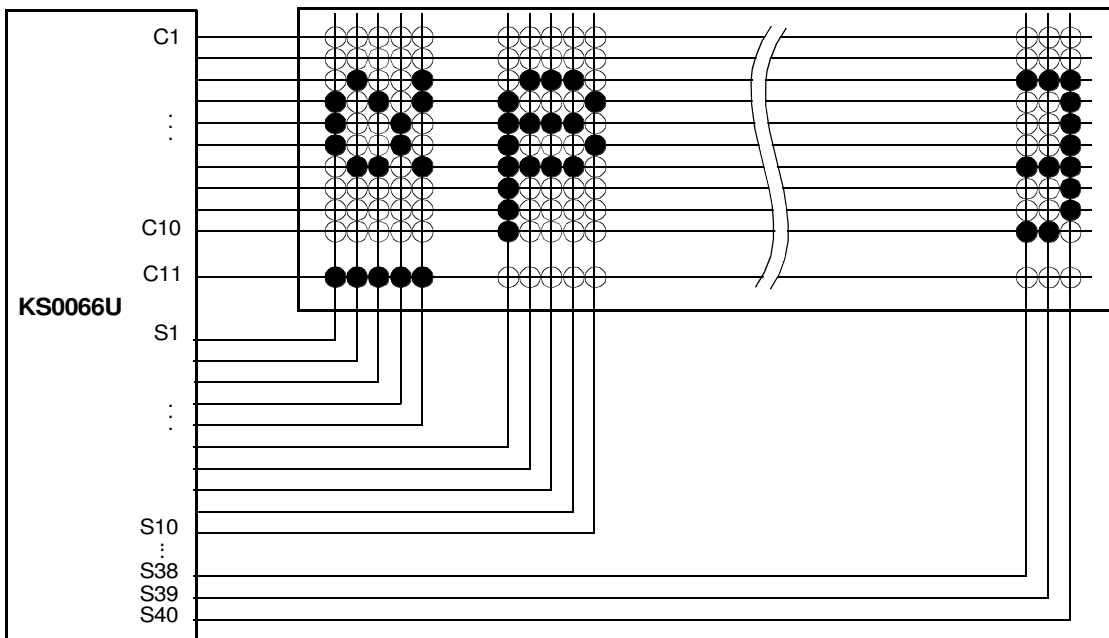

3) LCD Panel: 8 characters x 2-line format (5x7 dots + line, 1/5 bias, 1/16 duty)

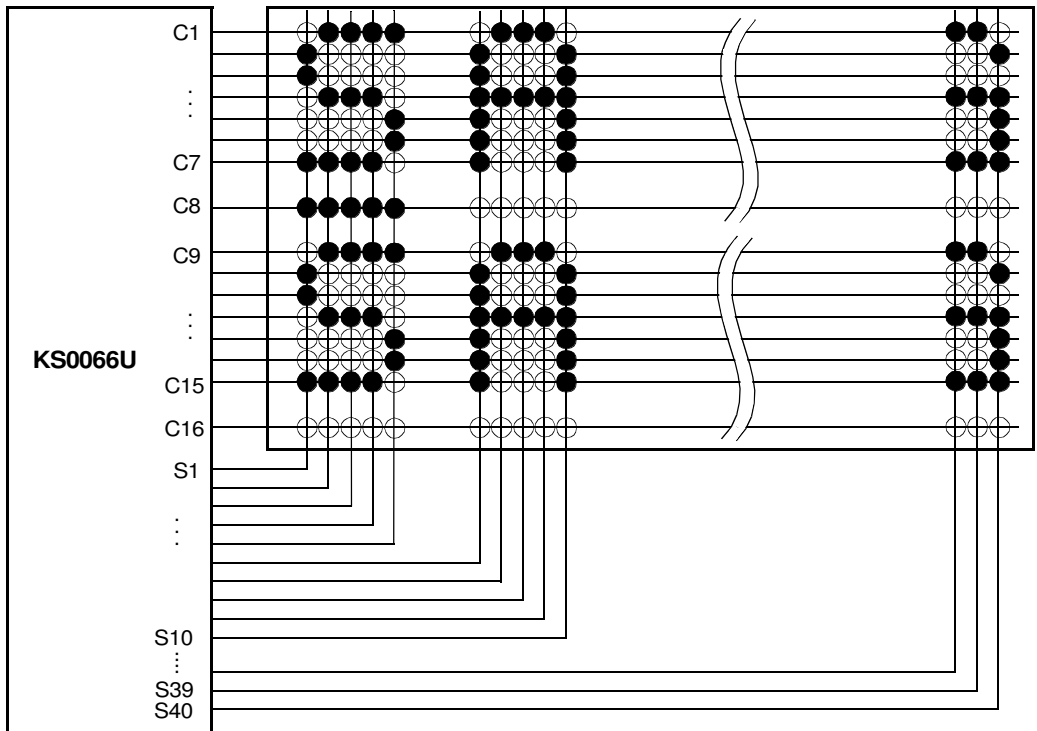

4) LCD Panel: 16 characters x 1-line format (5x7 dots + 1 cursor line, 1/5 bias, 1/16 duty)

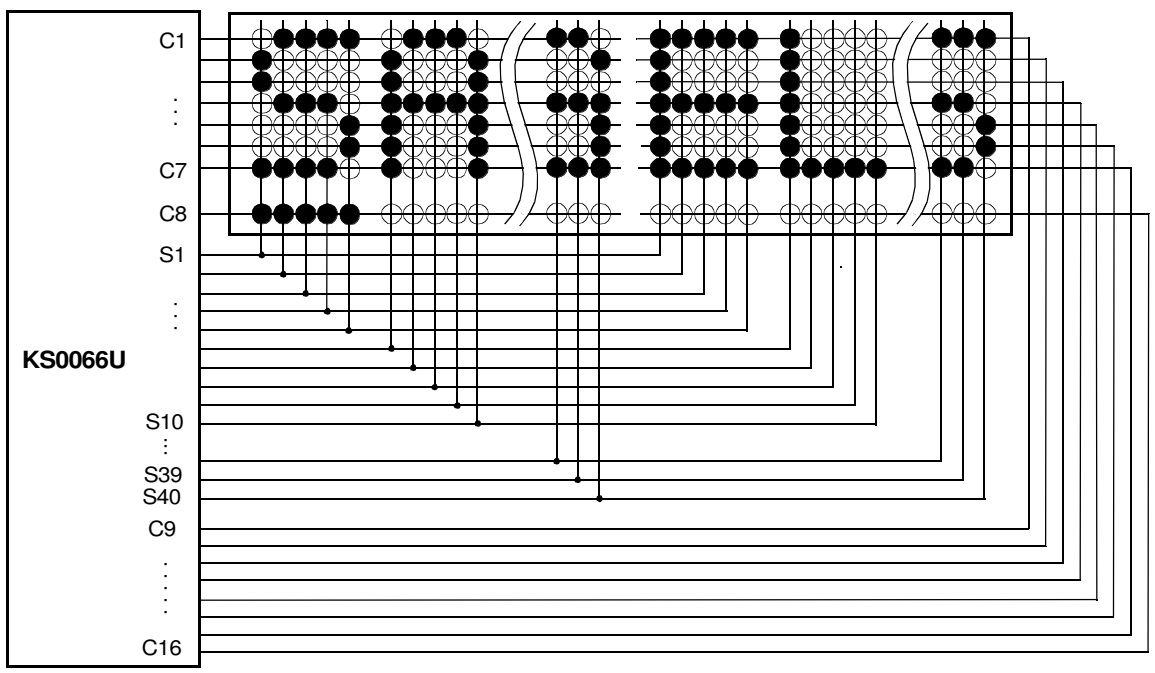

5) LCD Panel: 4 characters x 2-line format (5x7 dots + 1 cursor line, 1/4 bias, 1/8 duty)

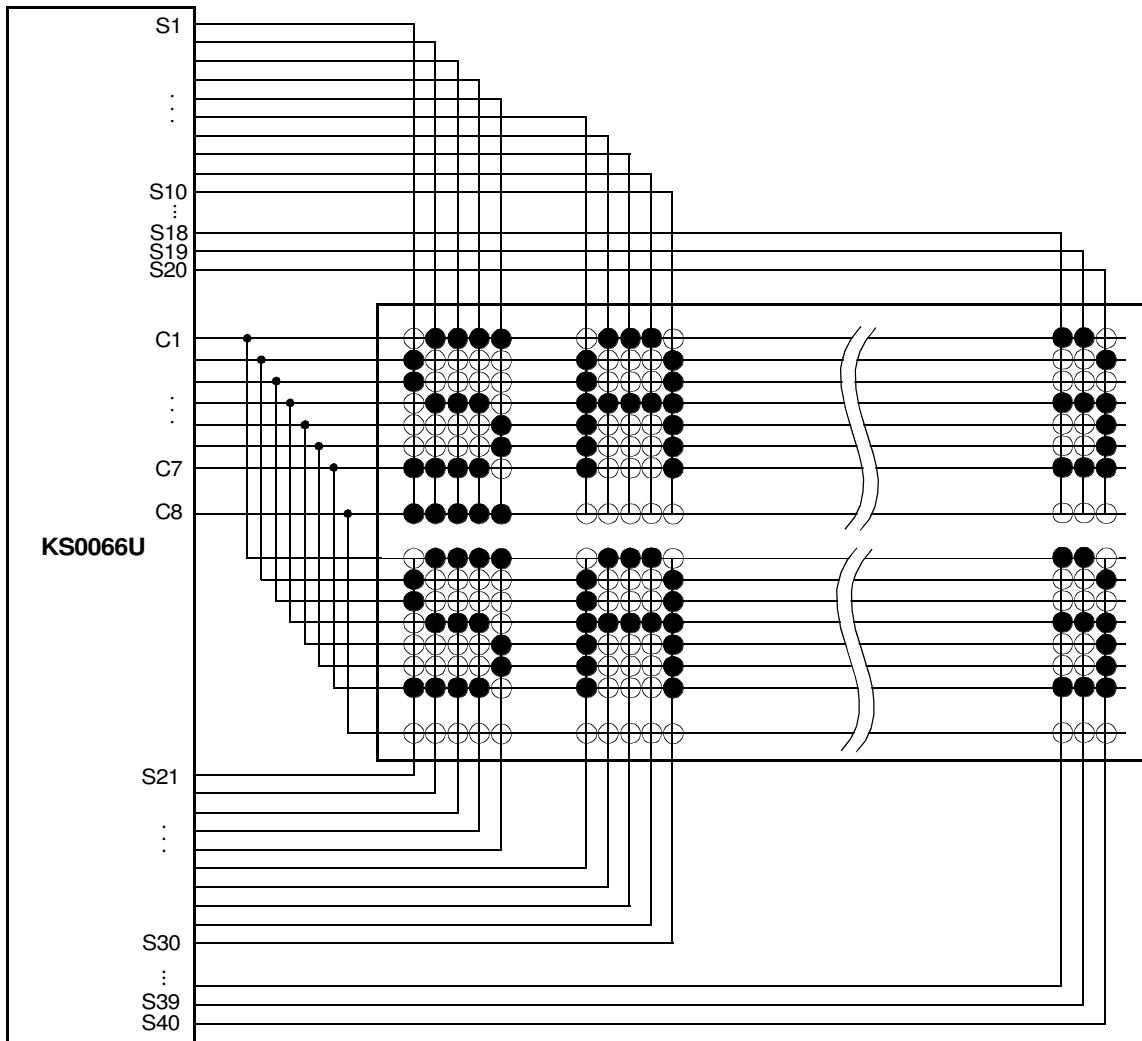

6) APPLICATION CIRCUIT

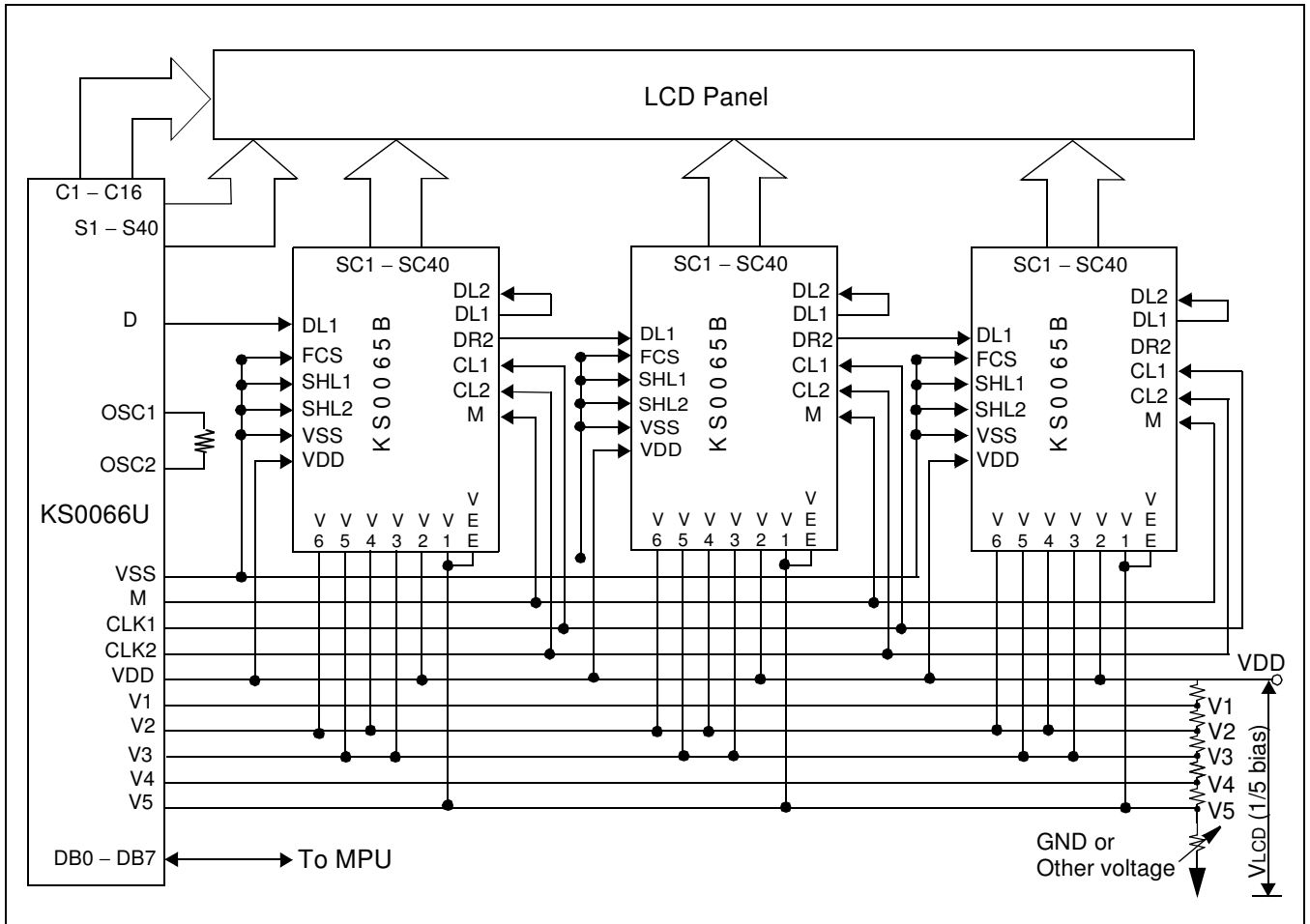

NOTE: When KS0065B is externally connected to the KS0066U, you can increase the number of display digits up to 80 characters.

BIAS VOLTAGE DIVIDE CIRCUIT

1) 1/4 bias, 1/8 or 1/11 duty

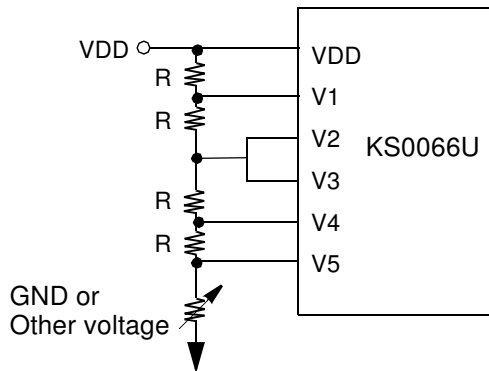

2) 1/5 bias, 1/16 duty

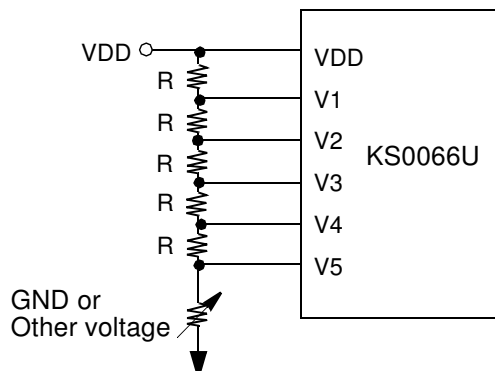

**INITIALIZING**

When the power is turned on, KS0066U is initialized automatically by power on reset circuit. During the initialization, the following instructions are executed, and BF (Busy Flag) is kept 'High' (busy state) to the end of initialization.

- (1) Display Clear instruction: Write '20H' to all DDRAM
- (2) Set Functions instruction: DL = 'High': 8-bit bus mode  
 N = 'Low': 1-line display mode  
 F = 'Low': 5 X 8 font type
- (3) Control Display ON/OFF instruction: D = 'Low': Display OFF  
 C = 'Low': Cursor OFF  
 B = 'Low': Blink OFF
- (4) Set Entry Mode instruction: I/D = 'High': Increment by 1  
 SH = 'Low': No entire display shift

**FRAME FREQUENCY**

Programmable Driving Method by the same font mask option: Display waveform A-Type, B-Type

1) 1/8 duty cycle

A) A-type Waveform

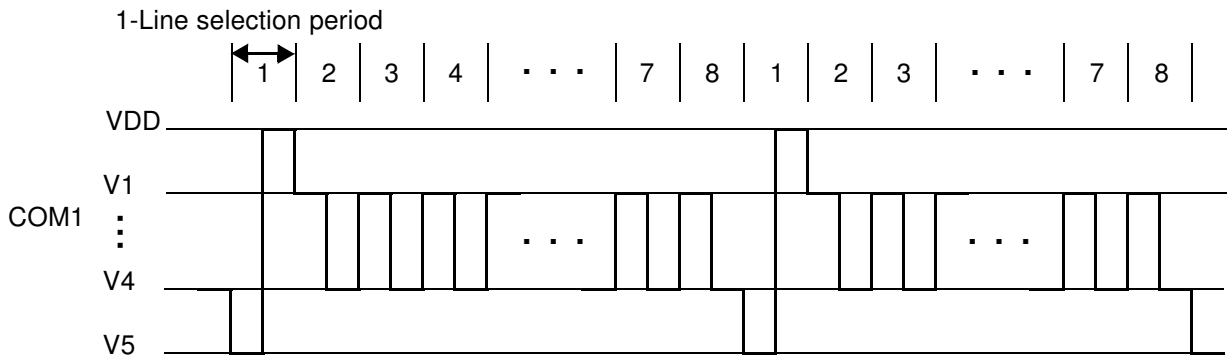

B) B-type Waveform

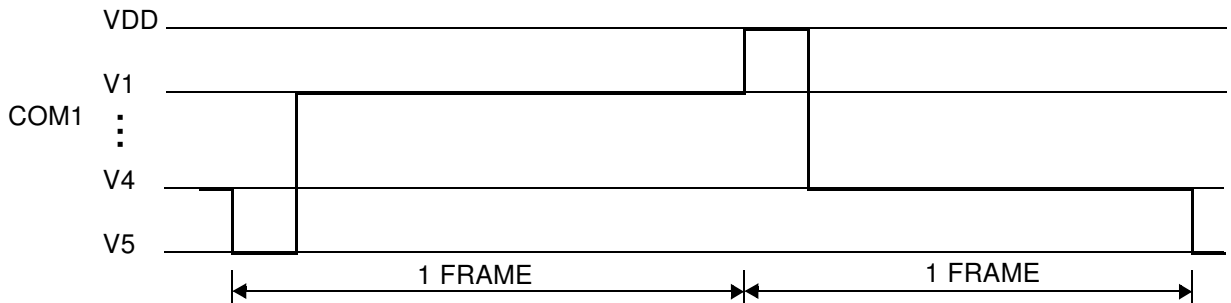

1-Line selection period = 400 clocks  
 1 Frame =  $400 \times 8 \times 3.7 \mu s = 11850 \mu s = 11.9 \text{ ms}$  (1 clock=3.7  $\mu s$ , fosc=270 kHz)  
 Frame frequency =  $1 / 11.9 \text{ ms} = 84.4 \text{ Hz}$

2) 1/11 duty cycle

A) A-type Waveform

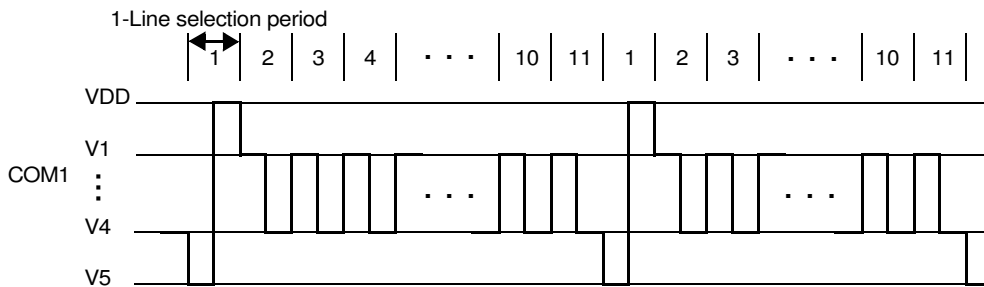

B) B-type Waveform

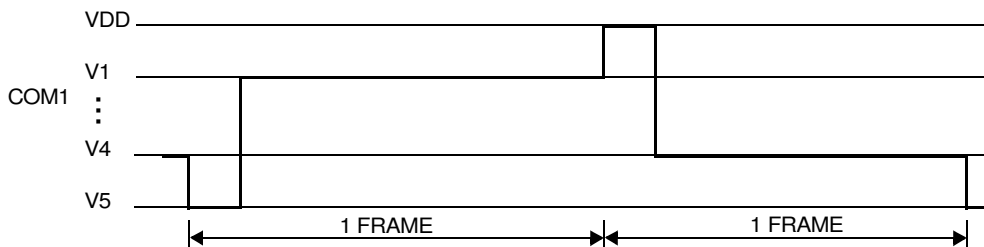

1-Line selection period = 400 clocks  
 1 Frame =  $400 \times 11 \times 3.7 \mu\text{s} = 16300 \mu\text{s} = 16.3 \text{ ms}$  (1 clock=3.7  $\mu\text{s}$ , fosc=270 kHz)  
 Frame frequency =  $1 / 16.3 \text{ ms} = 61.4 \text{ Hz}$

3) 1/16 duty cycle

A) A-type Waveform

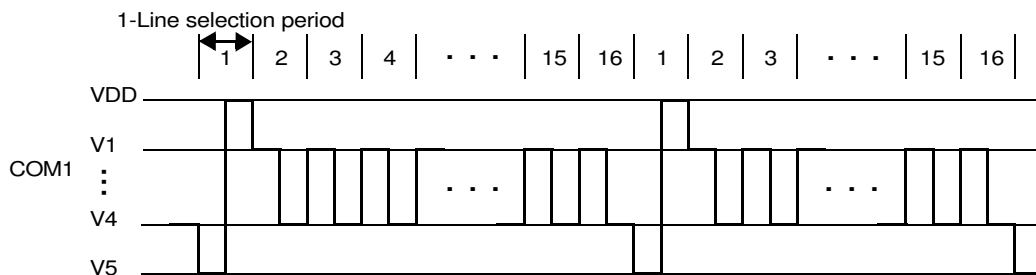

B) B-type Waveform

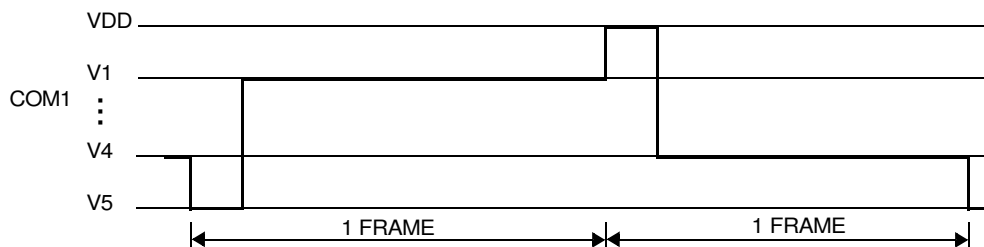

1-Line selection period = 200 clocks  
 1 Frame =  $200 \times 16 \times 3.7 \mu\text{s} = 11850 \mu\text{s} = 11.9 \text{ ms}$  (1 clock=3.7  $\mu\text{s}$ , fosc=270 kHz)  
 Frame frequency =  $1 / 11.9 \text{ ms} = 84.3 \text{ Hz}$

**INITIALIZING BY INSTRUCTION**

1) 8-bit interface mode (Condition: fosc = 270KHZ)

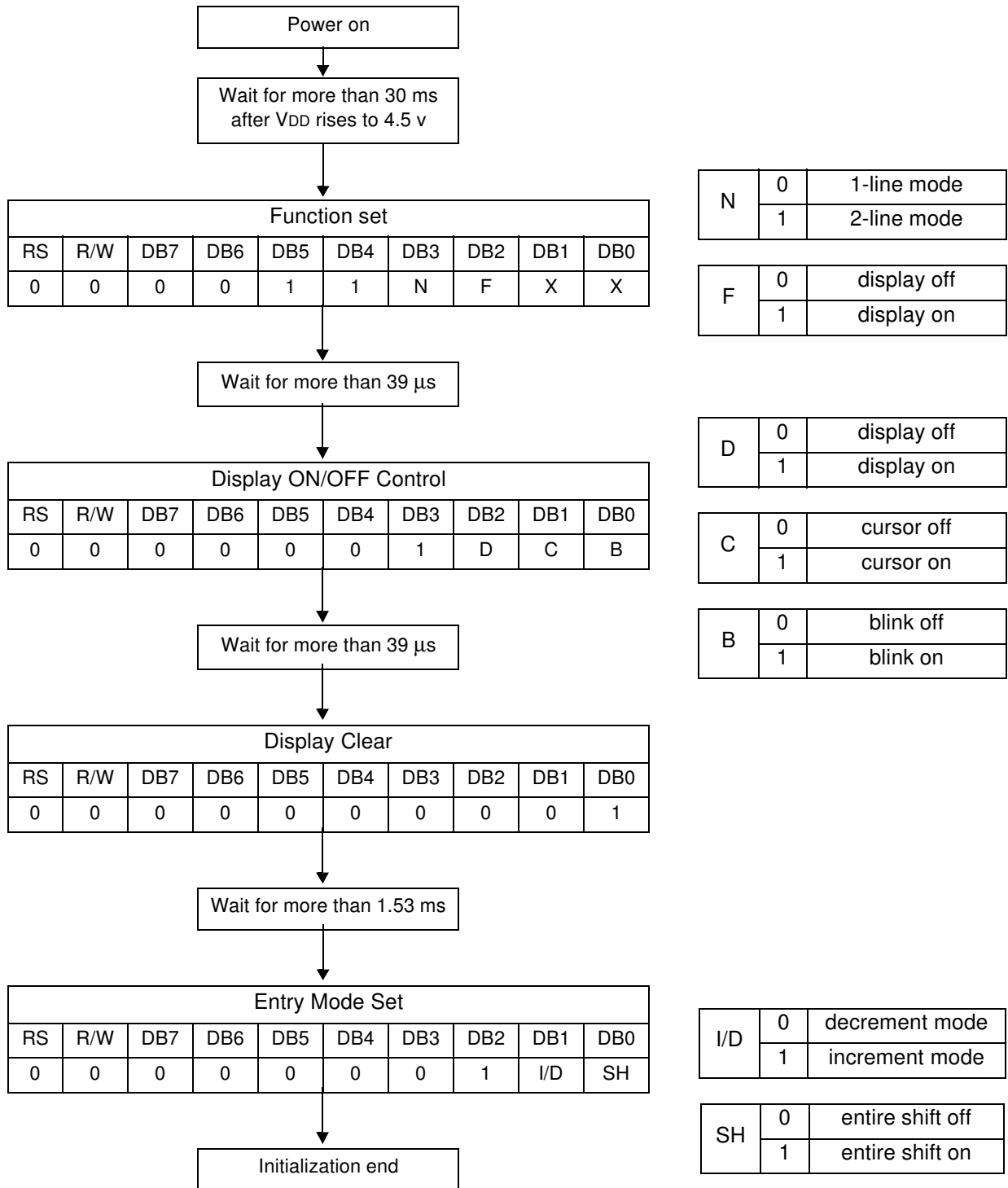

2) 4-bit interface mode (Condition: fosc = 270KHZ)

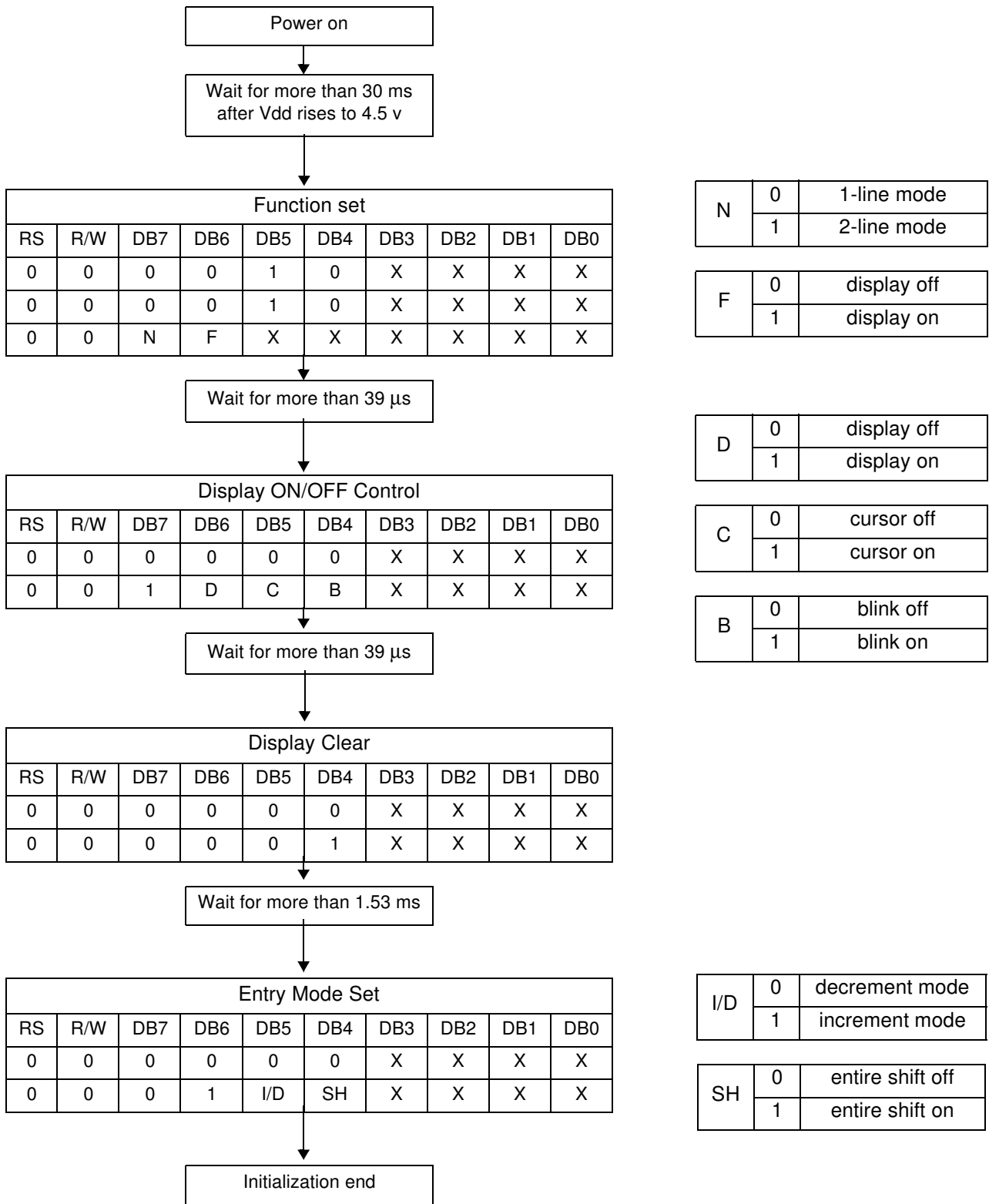

## MAXIMUM ABSOLUTE LIMIT

Table 8. Maximum Absolute Power Ratings

Characteristic	Symbol	Unit	Value
Power Supply Voltage(1)	$V_{DD}$	V	-0.3 ~ +7.0
Power Supply Voltage(2)	$V_{LCD}$	V	$V_{DD}-15.0 \sim V_{DD}+0.3$
Input Voltage	$V_{IN}$	V	-0.3 ~ $V_{DD}+0.3$

NOTE: Voltage greater than above may damage the circuit.

$$V_{DD} \geq V1 \geq V2 \geq V3 \geq V4 \geq V5$$

Table 9. Temperature characteristics

Characteristic	Symbol	Unit	Value
Operating Temperature	$T_{OPR}$	°C	-30 ~ +85
Storage Temperature	$T_{STG}$	°C	-55 ~ +125

## ELECTRICAL CHARACTERISTICS

## DC Characteristics

Table 10. DC Characteristics ( $V_{DD} = 4.5V \sim 5.5V$ ,  $T_a = -30 \sim +85^{\circ}C$ )

Characteristic	Symbol	Condition	Min.	Typ.	Max.	Unit
Operating Voltage	$V_{DD}$	-	4.5	-	5.5	V
Supply Current	$I_{DD}$	Internal oscillation or external clock. ( $V_{DD}=5.0V$ , $f_{osc} = 270kHz$ )	-	0.35	0.6	mA
Input Voltage (1) (except OSC1)	$V_{IH1}$	-	2.2	-	$V_{DD}$	V
	$V_{IL1}$	-	-0.3	-	0.6	
Input Voltage (2) (OSC1)	$V_{IH2}$	-	$V_{DD}-1.0$	-	$V_{DD}$	V
	$V_{IL2}$	-	-0.2	-	1.0	
Output Voltage (1) (DB0 to DB7)	$V_{OH1}$	$I_{OH} = -0.205mA$	2.4	-	-	V
	$V_{OL1}$	$I_{OL} = 1.2mA$	-	-	0.4	
Output Voltage (2) (except DB0 to DB7)	$V_{OH2}$	$I_O = -40\mu A$	$0.9V_{DD}$	-	-	V
	$V_{OL2}$	$I_O = 40\mu A$	-	-	$0.1V_{DD}$	
Voltage Drop	$V_{dCOM}$	$I_O = \pm 0.1mA$	-	-	1	V
	$V_{dSEG}$		-	-	1	
Input Leakage Current	$I_{IKG}$	$V_{IN} = 0V$ to $V_{DD}$	-1	-	1	$\mu A$
Input Low Current	$I_{IL}$	$V_{IN} = 0V$ , $V_{DD} = 5V$ (PULL UP)	-50	-125	-250	
Internal Clock (external Rf)	$f_{OSC1}$	$R_f = 91k\Omega \pm 2\%$ ( $V_{DD} = 5V$ )	190	270	350	kHz
External Clock	$f_{OSC}$	-	125	270	410	kHz
	duty		45	50	55	%
	$t_R, t_F$		-	-	0.2	$\mu s$
LCD Driving Voltage	$V_{LCD}$	$V_{DD}-V_5$ (1/5, 1/4 Bias)	3.0	-	13.0	V

Table 11. DC Characteristic ( $V_{DD} = 2.7V \sim 4.5V$ ,  $T_a = -30 \sim +85^{\circ}C$ )

Characteristic	Symbol	Condition	Min.	Typ.	Max.	Unit
Operating Voltage	$V_{DD}$	-	2.7	-	4.5	V
Supply Current	$I_{DD}$	Internal oscillation or external clock. ( $V_{DD}=3.0V$ , $f_{osc} = 270kHz$ )	-	0.15	0.3	mA
Input Voltage (1) (except OSC1)	$V_{IH1}$	-	$0.7V_{DD}$	-	$V_{DD}$	V
	$V_{IL1}$	-	-0.3	-	0.55	
Input Voltage (2) (OSC1)	$V_{IH2}$	-	$0.7V_{DD}$	-	$V_{DD}$	V
	$V_{IL2}$	-	-	-	$0.2V_{DD}$	
Output Voltage (1) (DB0 to DB7)	$V_{OH1}$	$I_{OH} = -0.1mA$	$0.75V_{DD}$	-	-	V
	$V_{OL1}$	$I_{OL} = 0.1mA$	-	-	$0.2V_{DD}$	
Output Voltage (2) (except DB0 to DB7)	$V_{OH2}$	$I_O = -40\mu A$	$0.8V_{DD}$	-	-	V
	$V_{OL2}$	$I_O = 40\mu A$	-	-	$0.2V_{DD}$	
Voltage Drop	$V_{dCOM}$	$I_O = \pm 0.1mA$	-	-	1	V
	$V_{dSEG}$		-	-	1	
Input Leakage Current	$I_{IKG}$	$V_{IN} = 0V$ to $V_{DD}$	-1	-	1	$\mu A$
Input Low Current	$I_{IL}$	$V_{IN} = 0V$ , $V_{DD} = 3V$ (PULL UP)	-10	-50	-120	
Internal Clock (external $R_f$ )	$f_{OSC1}$	$R_f = 75k\Omega \pm 2\%$ ( $V_{DD} = 3V$ )	190	270	350	kHz
External Clock	$f_{OSC2}$	-	125	270	410	kHz
	duty		45	50	55	%
	$t_R, t_F$		-	-	0.2	$\mu s$
LCD Driving Voltage	$V_{LCD}$	$V_{DD}-V_5$ (1/5, 1/4 Bias)	3.0	-	13.0	V

NOTE: LCD Driving Voltage

Power	Duty	1/8, 1/11 Duty	1/16 Duty
	Bias	1/4 Bias	1/5 Bias
$V_{DD}$		$V_{DD}$	$V_{DD}$
$V_1$		$V_{DD}-V_{LCD}/4$	$V_{DD}-V_{LCD}/5$
$V_2$		$V_{DD}-V_{LCD}/2$	$V_{DD}-2V_{LCD}/5$
$V_3$		$V_{DD}-V_{LCD}/2$	$V_{DD}-3V_{LCD}/5$
$V_4$		$V_{DD}-3V_{LCD}/4$	$V_{DD}-4V_{LCD}/5$
$V_5$		$V_{DD}-V_{LCD}$	$V_{DD}-V_{LCD}$

## AC Characteristics

Table 12. AC Characteristics ( $V_{DD} = 4.5V \sim 5.5V$ ,  $T_a = -30 \sim +85^{\circ}C$ )

Mode	Characteristic	Symbol	Min.	Typ.	Max.	Unit
Write Mode (Refer to Fig-6)	E Cycle Time	$t_c$	500	-	-	ns
	E Rise / Fall Time	$t_R, t_F$	-	-	20	
	E Pulse Width (High, Low)	$t_w$	230	-	-	
	R/W and RS Setup Time	$t_{su1}$	40	-	-	
	R/W and RS Hold Time	$t_{H1}$	10	-	-	
	Data Setup Time	$t_{su2}$	80	-	-	
	Data Hold Time	$t_{H2}$	10	-	-	
Read Mode (Refer to Fig-7)	E Cycle Time	$t_c$	500	-	-	ns
	E Rise / Fall Time	$t_R, t_F$	-	-	20	
	E Pulse Width (High, Low)	$t_w$	230	-	-	
	R/W and RS Setup Time	$t_{su}$	40	-	-	
	R/W and RS Hold Time	$t_H$	10	-	-	
	Data Output Delay Time	$t_D$	-	-	120	
	Data Hold Time	$t_{DH}$	5	-	-	

Table 13. AC Characteristics ( $V_{DD} = 2.7V \sim 4.5V$ ,  $T_a = -30 \sim +85^{\circ}C$ )

Mode	Characteristic	Symbol	Min.	Typ.	Max.	Unit
Write Mode (Refer to Fig-6)	E Cycle Time	$t_c$	1000	-	-	ns
	E Rise / Fall Time	$t_R, t_F$	-	-	25	
	E Pulse Width (High, Low)	$t_w$	450	-	-	
	R/W and RS Setup Time	$t_{su1}$	60	-	-	
	R/W and RS Hold Time	$t_{H1}$	20	-	-	
	Data Setup Time	$t_{su2}$	195	-	-	
	Data Hold Time	$t_{H2}$	10	-	-	
Read Mode (Refer to Fig-7)	E Cycle Time	$t_c$	1000	-	-	ns
	E Rise / Fall Time	$t_R, t_F$	-	-	25	
	E Pulse Width (High, Low)	$t_w$	450	-	-	
	R/W and RS Setup Time	$t_{su}$	60	-	-	
	R/W and RS Hold Time	$t_H$	20	-	-	
	Data Output Delay Time	$t_D$	-	-	360	
	Data Hold Time	$t_{DH}$	5	-	-	

Table 14. AC Characteristics ( $V_{DD} = 2.7V \sim 4.5V$ ,  $T_a = -30 \sim +85^{\circ}C$ )

Mode	Characteristic	Symbol	Min.	Typ.	Max.	Unit
Interface Mode with Extension Driver (Refer to Fig-8)	Clock Pulse Width (High, Low)	$t_c$	800	-	-	ns
	Clock Rise / Fall Time	$t_R, t_F$	-	-	25	
	Clock Setup Time	$t_{su1}$	500	-	-	
	Data Setup Time	$t_{su2}$	300	-	-	
	Data Hold Time	$t_{DH}$	300	-	-	
	M Delay Time	$t_{DM}$	-1000	-	1000	

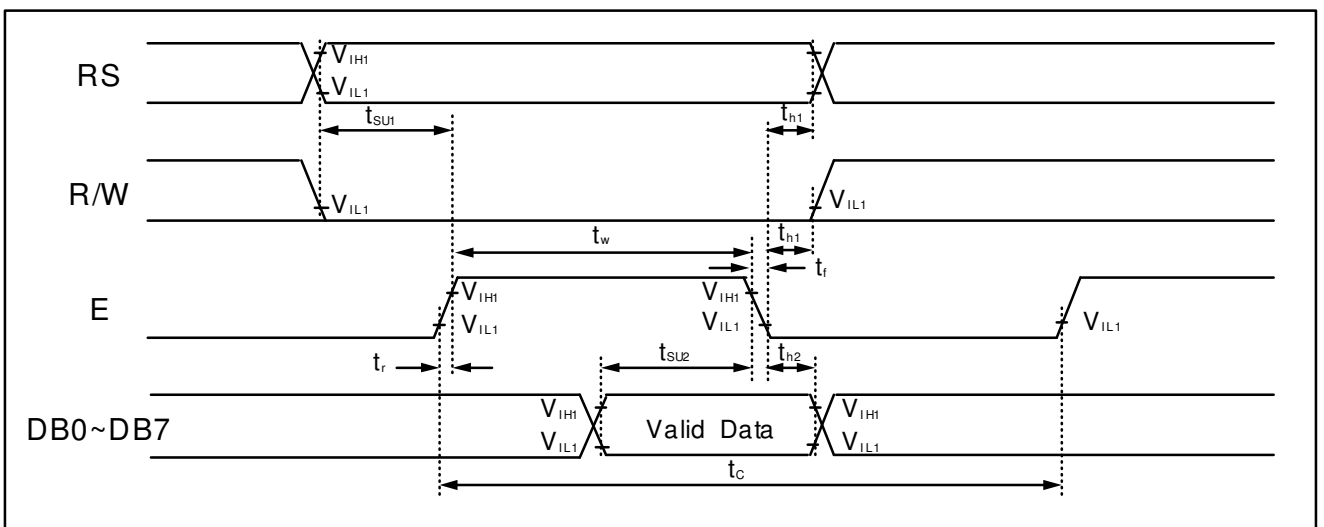

Figure 6 . Write Mode Timing Diagram

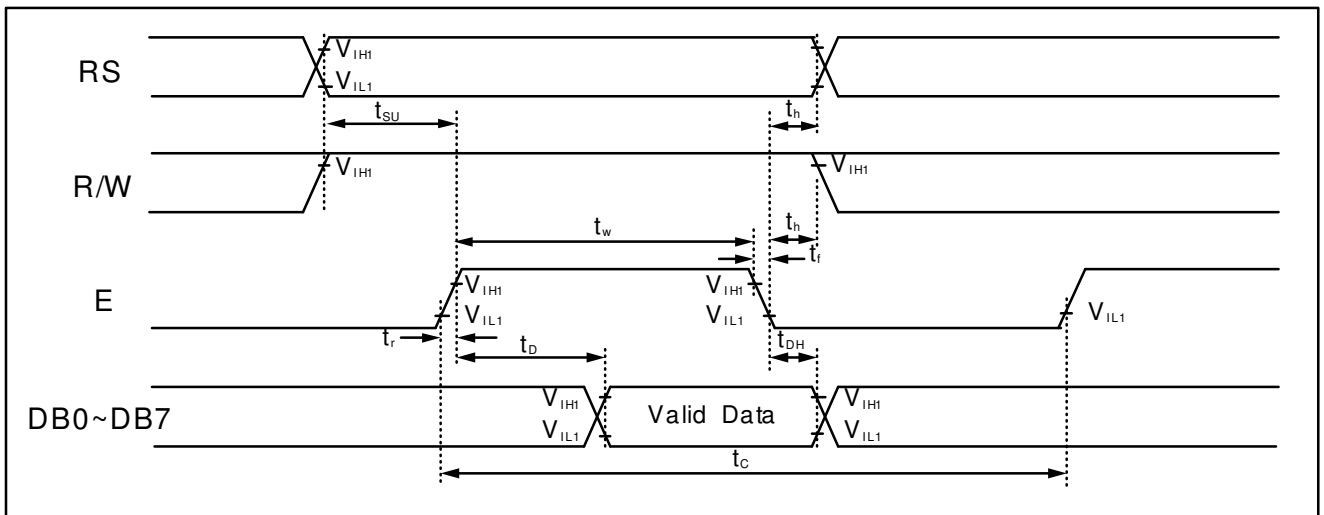

Figure 7 . Read Mode Timing Diagram

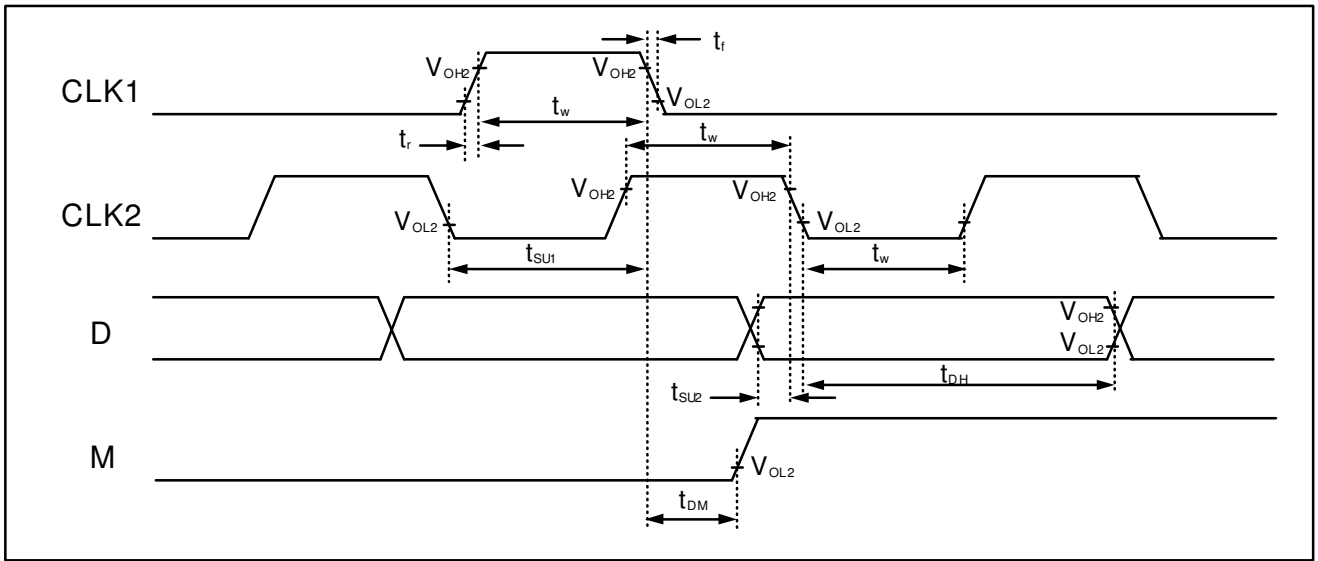

Figure 8 . Interface Mode With Extension Driver Timing Diagram