

---

# HD66712U

(Dot-Matrix Liquid Crystal Display Controller/Driver)

## HITACHI

---

### Description

The HD66712 dot-matrix liquid crystal display controller and driver LSI displays alphanumerics, numbers, and symbols. It can be configured to drive a dot-matrix liquid crystal display under the control of a serial or a 4- or 8-bit microprocessor. Since all the functions such as display RAM, character generator, and liquid crystal driver, required for driving a dot-matrix liquid crystal display are internally provided on one chip, a minimum system can be interfaced with this controller/driver.

A single HD66712 is capable of displaying a single 24-character line, two 24-character lines, or four 12-character lines.

The HD66712 software is upwardly compatible with the LCDII (HD44780) which allows the user to easily replace an LCD-II with an HD66712. In addition, the HD66712 is equipped with functions such as segment displays for icon marks, a 4-line display mode, and a horizontal smooth scroll, and thus supports various display forms. This achieves various display forms. The HD66712 character generator ROM is extended to generate 240  $5 \times 8$  dot characters.

The low-voltage operation (2.7V) of the HD66712, combined with a low-power mode, is suitable for any portable battery-driven product requiring low power consumption.

### Features

- $5 \times 8$  dot matrix possible
- Clock-synchronized serial interface capability; can interface with 4- or 8-bit MPU
- Low-power operation support:
  - 2.7 to 5.5V (low voltage)
  - Wide liquid-crystal voltage range: 2.7 to 11.0V max.
- Booster for liquid crystal voltage
  - Two/three times (13V max.)
- High-speed MPU bus interface  
(2MHz at 5-V operation)

- Extension driver interface
- Character display and independent 60-icon mark display possible
- Horizontal smooth scroll by 6-dot font width display possible
- 80 × 8-bit display RAM (80 characters max.)
- 9,600-bit character generator ROM
  - 240 characters (5 × 8 dot)
- 64 × 8-bit character generator RAM
  - 8 characters (5 × 8 dot)
- 16 × 8-bit segment icon mark
  - 96-segment icon mark
- 34-common × 60-segment liquid crystal display driver
- Programmable duty cycle  
(See List 1)
- Software upwardly compatible with HD44780
- Wide range of instruction functions:
  - Functions compatible with LCD-II: Display clear, cursor home, display on/off, cursor on/off, display character blink, cursor shift, display shift
  - Additional functions: Icon mark control, 4-line display, horizontal smooth scroll, 6-dot character width control, white-black inverting blinking cursor
- Automatic reset circuit that initializes the controller/driver after power on (standard version only)
- Internal oscillator with an external resistor
- Low power consumption
- TCP-128 pin, bare-chip

**List 1 Programmable Duty Cycles**

Number of Lines	Duty Ratio	5-Dot Font Width		6-Dot Font Width	
		Displayed Characters	Icons	Displayed Characters	Icons
1	1/17	One 24-character line	60	One 20-character lines	60
2	1/33	Two 24-character lines	60	Two 20-character lines	60
3	1/33	Four 12-character lines	60	Four 10-character lines	60

---

## HD66712U

---

### Ordering Information

Type No.	Package	CGROM
HD66712SA00FS	QFP1420-128 (FP-128)	Japanese standard
HD66712SA01FS	QFP1420-128 (FP-128)	Communication
HD66712SA02FS	QFP1420-128 (FP-128)	European font
HCD66712UA02	Chip	
HD66712UA02TA0	Standard TCP-128	
HD66712UA03TA0	Standard TCP-128	Japanese + European font
HCD66712UA03	Chip	
HCD66712UA03BP	Chip with bump	

**LCD-II Family Comparison**

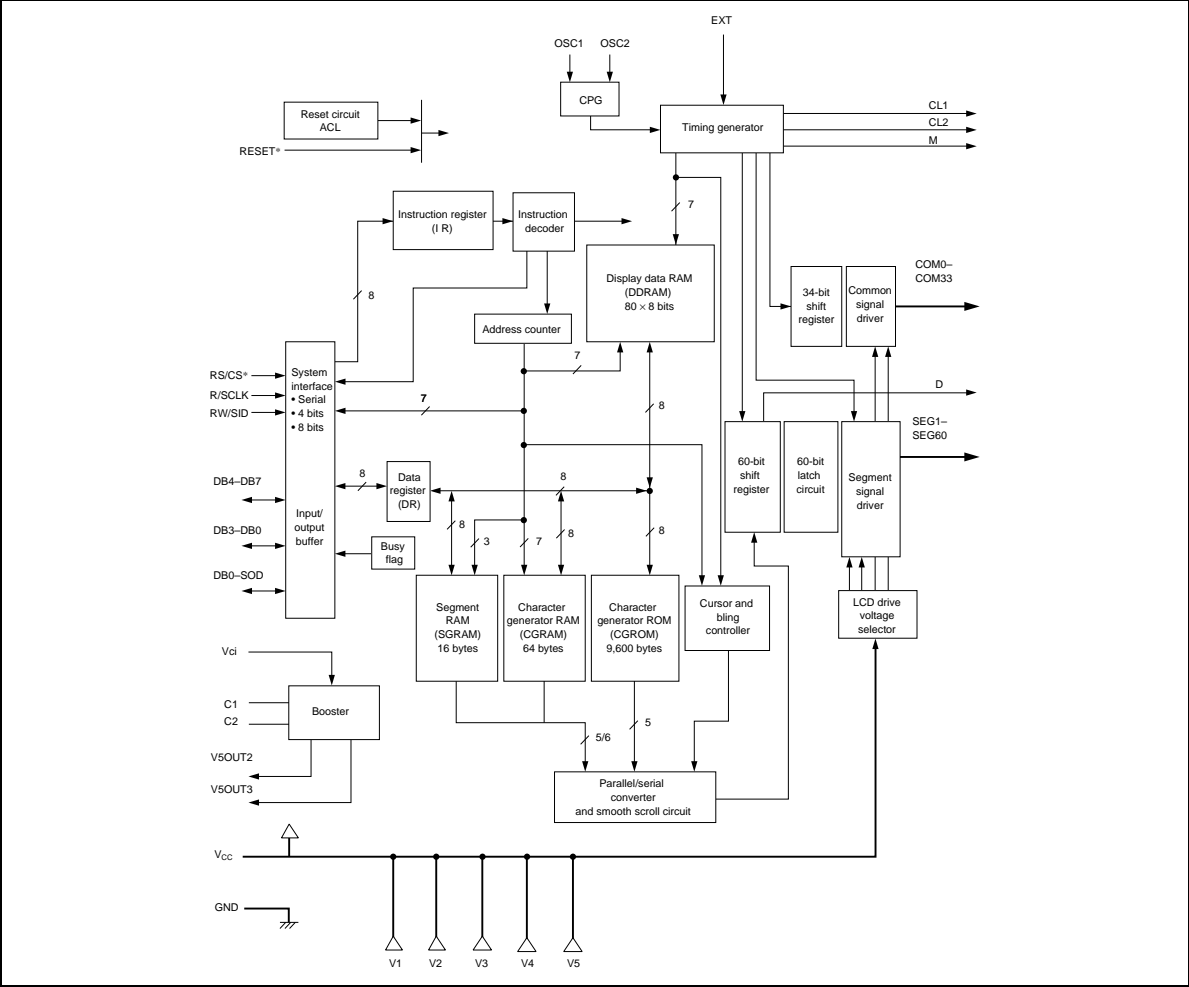
<b>Item</b>	<b>HD66702</b>	<b>HD66710</b>	<b>HD66712S</b>	<b>HD66712U</b>
Power supply voltage	5V ±10 % (standard) 2.7V to 5.5V (low voltage)	2.7V to 5.5V	2.7V to 5.5V	←
Liquid crystal drive voltage	3.0V to 8.3V	3.0V to 13.0V	3.0V to 13.0V	2.7V to 11.0V
Maximum display digits per chip	20 characters × 2 lines	16 characters × 2 lines/ 8 characters × 4 lines	24 characters × 2 lines/ 12 characters × 4 lines	←
Segment display	None	40 segments	60 segments	←
Display duty cycle	1/8, 1/11, and 1/16	1/17 and 1/33	1/17 and 1/33	←
CGROM	7,200 bits (160 5 × 7 dot characters and 32 5 × 10 dot characters)	9,600 bits (240 5 × 8 dot characters)	9,600 bits (240 5 × 8 dot characters)	←
CGRAM	64 bytes	64 bytes	64 bytes	←
DDRAM	80 bytes	80 bytes	80 bytes	←
SEGRAM	None	8 bytes	16 bytes	←
Segment signals	100	40	60	←
Common signals	16	33	34	←
Liquid crystal drive waveform	B	B	B	←
Bleeder resistor for LCD power supply	External (adjustable)	External (adjustable)	External (adjustable)	←
Clock source	External resistor or external clock	External resistor or external clock	External resistor or external clock	←
R <sub>i</sub> oscillation frequency (frame frequency)	320 kHz ±30% (70 to 130 Hz for 1/8 and 1/16 duty cycle; 51 to 95 Hz for 1/11 duty cycle)	270 kHz ±30% (56 to 103 Hz for 1/17 duty cycle; 57 to 106 Hz for 1/33 duty cycle)	270 kHz ±30% (56 to 103 Hz for 1/17 duty cycle; 57 to 106 Hz for 1/33 duty cycle)	←
R <sub>i</sub> resistance	68 kΩ: 5-V operation; 56 kΩ: (3-V operation)	91 kΩ: 5-V operation; 75 kΩ: 3-V operation	91 kΩ: 5-V operation; 75 kΩ: 3-V operation	130 kΩ: 5-V operation 110 kΩ: 3-V operation

---

## HD66712U

Item	HD66702	HD66710	HD66712S	HD66712U
Liquid crystal voltage booster circuit	None	2-3 times step-up circuit	2-3 times step-up circuit	←
Extension driver control signal	Independent control signal	Used in common with a driver output pin	Independent control signal	←
Reset function	Power on automatic reset	Power on automatic reset	Power on automatic reset or Reset input	←
Instructions	Fully compatible with the LCD-II	Uppercompatible with the LCD-II	Upper compatible with the LCD-II	←
Number of displayed lines	1 or 2	1, 2, or 4	1, 2, or 4	←
Low power mode	None	Available	Available	←
Horizontal scroll	Character unit	Dot unit	Dot unit	←
Bus interface	4 bits/8 bits	4 bits/8 bits	Serial; 4 bits/8 bits	←
CPU bus timing	1 MHz	2 MHz: 5-V operation; 1 MHz: 3-V operation	2 MHz: 5-V operation; 1 MHz: 3-V operation	←
Current consumption	150 $\mu$ A (typ)	150 $\mu$ A (typ)	150 $\mu$ A (typ) 100 $\mu$ A (LP mode, 1/33 duty) 75 $\mu$ A (LP mode, 1/17 duty)	120 $\mu$ A (typ) 85 $\mu$ A (LP mode, 1/33 duty) 60 $\mu$ A (LP mode, 1/17 duty)
Package	LQFP-2020-144 144-pin bare chip	QFP-1420-100 TQFP-1414-100 100-pin bare chip	QFP-1420-128 TCP-128 128-pin bare chip	TCP-128 128-pin bare chip

HD66712 Block Diagram

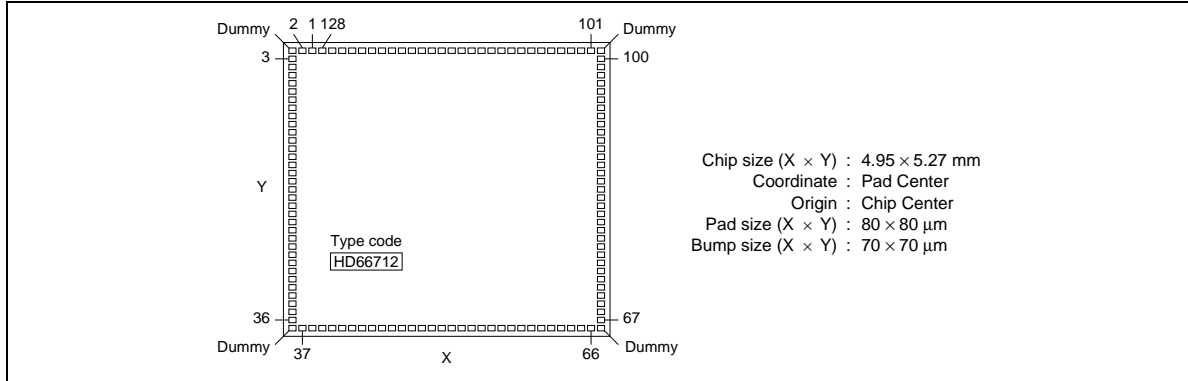


---

# HD66712U

---

## HCD66712

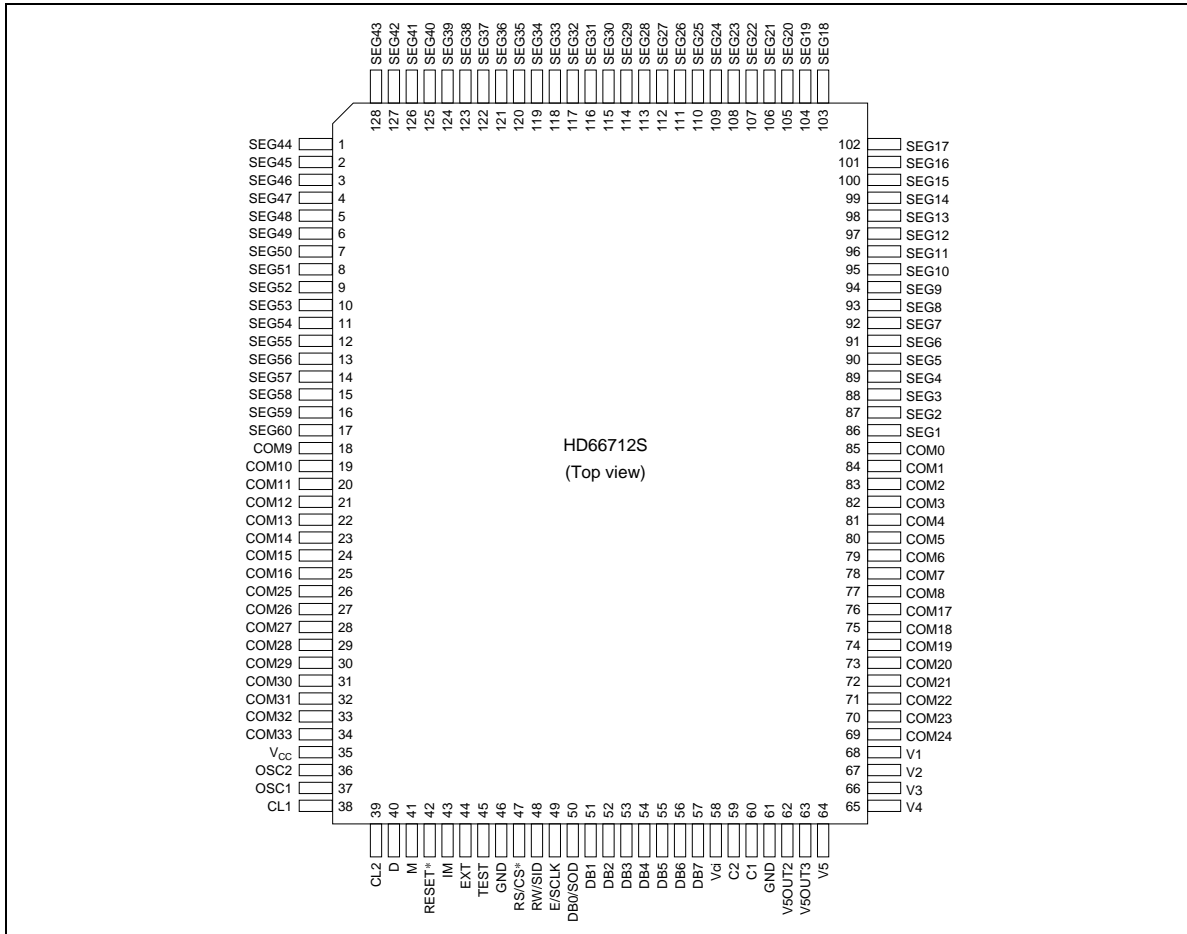


## HCD66712U Pad Coordinate

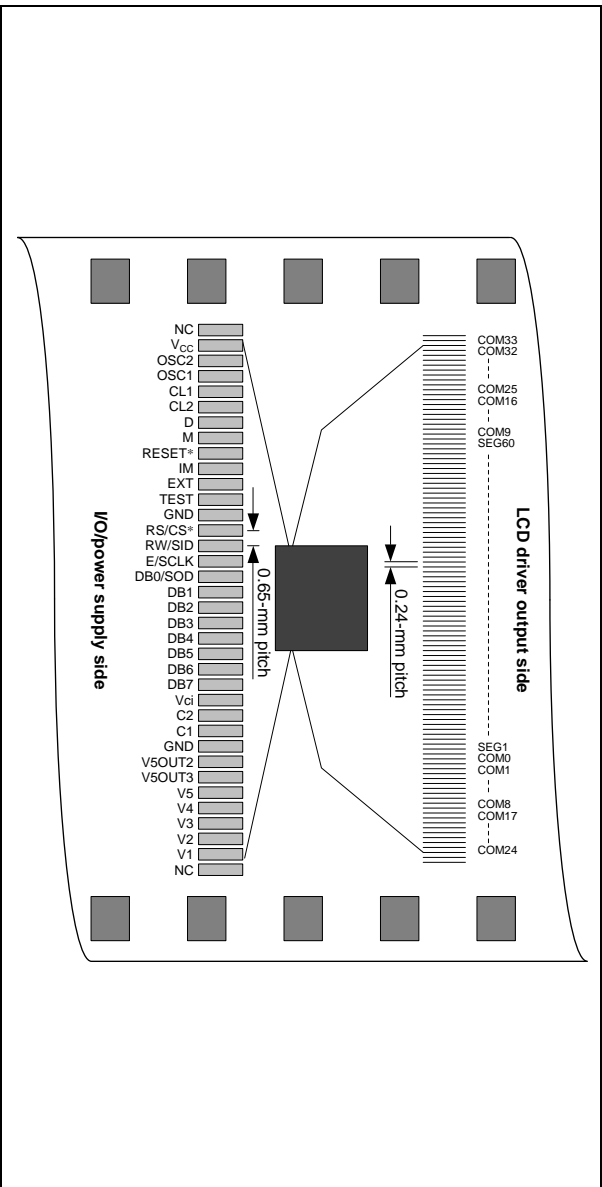
Pad No.	Function	Coordinate		Pad No.	Function	Coordinate		Pad No.	Function	Coordinate	
		X	Y			X	Y			X	Y
1	SEG44	-1960	2437	45	TEST	-1064	-2446	89	SEG4	2277	704
2	SEG45	-2120	2437	46	GND	-936	-2446	90	SEG5	2277	832
3	SEG46	-2277	2293	47	RS/CS	-792	-2446	91	SEG6	2277	960
4	SEG47	-2277	2149	48	RW/SID	-656	-2446	92	SEG7	2277	1088
5	SEG48	-2277	1872	49	E/SCLK	-520	-2446	93	SEG8	2277	1216
6	SEG49	-2277	1728	50	DB0/SOD	-384	-2446	94	SEG9	2277	1344
7	SEG50	-2277	1600	51	DB1	-248	-2446	95	SEG10	2277	1472
8	SEG51	-2277	1472	52	DB2	-112	-2446	96	SEG11	2277	1600
9	SEG52	-2277	1344	53	DB3	24	-2446	97	SEG12	2277	1728
10	SEG53	-2277	1216	54	DB4	160	-2446	98	SEG13	2277	1872
11	SEG54	-2277	1088	55	DB5	296	-2446	99	SEG14	2277	2149
12	SEG55	-2277	960	56	DB6	432	-2446	100	SEG15	2277	2293
13	SEG56	-2277	832	57	DB7	568	-2446	101	SEG16	2120	2437
14	SEG57	-2277	704	58	Vci	704	-2446	102	SEG17	1960	2437
15	SEG58	-2277	576	59	C2	850	-2446	103	SEG18	1800	2437
16	SEG59	-2277	448	60	C1	1001	-2426	104	SEG19	1656	2437
17	SEG60	-2277	320	61	GND	1141	-2402	105	SEG20	1512	2437
18	COM9	-2277	192	62	V5OUT2	1376	-2446	106	SEG21	1368	2437
19	COM10	-2277	64	63	V5OUT3	1640	-2446	107	SEG22	1224	2437
20	COM11	-2277	-64	64	V5	1800	-2446	108	SEG23	1080	2437
21	COM12	-2277	-192	65	V4	1960	-2446	109	SEG24	936	2437
22	COM13	-2277	-320	66	V3	2120	-2446	110	SEG25	792	2437
23	COM14	-2277	-448	67	V2	2302	-2304	111	SEG26	648	2437
24	COM15	-2277	-576	68	V1	2302	-2162	112	SEG27	504	2437
25	COM16	-2277	-704	69	COM24	2277	-1856	113	SEG28	360	2437
26	COM25	-2277	-832	70	COM23	2277	-1728	114	SEG29	216	2437
27	COM26	-2277	-960	71	COM22	2277	-1600	115	SEG30	72	2437
28	COM27	-2277	-1088	72	COM21	2277	-1472	116	SEG31	-72	2437
29	COM28	-2277	-1216	73	COM20	2277	-1344	117	SEG32	-216	2437
30	COM29	-2277	-1344	74	COM19	2277	-1216	118	SEG33	-360	2437
31	COM30	-2277	-1472	75	COM18	2277	-1088	119	SEG34	-504	2437
32	COM31	-2277	-1600	76	COM17	2277	-960	120	SEG35	-648	2437
33	COM32	-2277	-1728	77	COM8	2277	-832	121	SEG36	-792	2437
34	COM33	-2277	-1856	78	COM7	2277	-704	122	SEG37	-936	2437
35	Vcc	-2286	-2158	79	COM6	2277	-576	123	SEG38	-1080	2437
36	OSC2	-2286	-2302	80	COM5	2277	-448	124	SEG39	-1224	2437
37	OSC1	-2120	-2446	81	COM4	2277	-320	125	SEG40	-1368	2437
38	CL1	-1968	-2446	82	COM3	2277	-192	126	SEG41	-1512	2437
39	CL2	-1832	-2446	83	COM2	2277	-64	127	SEG42	-1656	2437
40	D	-1704	-2446	84	COM1	2277	64	128	SEG43	-1800	2437
41	M	-1576	-2446	85	COM0	2277	192	—	Dummy1	-2277	2437
42	RESET*	-1448	-2446	86	SEG1	2277	320	—	Dummy2	-2286	-2446
43	IM	-1320	-2446	87	SEG2	2277	448	—	Dummy3	2302	-2446
44	EXT	-1192	-2446	88	SEG3	2277	576	—	Dummy4	2277	2437

# HD66712U

## HD66712 Pin Arrangement



**TCP Dimensions**





## Pin Functions

**Table 1 Pin Functional Description**

Signal	Number of Pins	I/O	Device Interfaced with	Function
IM	1	I	—	Selects interface mode with the MPU; Low: Serial mode High: 4-bit/8-bit bus mode (Bus width is specified by instruction.)
RS/CS*	1	I	MPU	Selects registers during bus mode: Low: Instruction register (write); Busy flag, address counter (read) High: Data register (write/read) Acts as chip-select during serial mode: Low: Select (access enable) High: Not selected (access disable)
RW/SID	1	I	MPU	Selects read/write during bus mode; Low: Write High: Read Inputs serial data during serial mode.
E/SCLK	1	I	MPU	Starts data read/write during bus mode; Inputs (Receives) serial clock during serial mode.
DB4 to DB7	4	I/O	MPU	Four high-order bidirectional tristate data bus pins. Used for data transfer between the MPU and the HD66712. DB7 can be used as a busy flag. Open these pins during serial mode since those signals.
DB1 to DB3	3	I/O	MPU	Three low order bidirectional tristate data bus pins. Used for data transfer between the MPU and the HD66712. Open these pins during 4-bit operation or serial mode since they are not used.
DB0/ SOD	1	I/O /O	MPU	The lowest bidirectional data bit (DB0) during 8-bit bus mode. Open these pins during 4-bit mode since they are not used. Outputs (transfers) serial data during serial mode. Open this pin if reading (transfer) is not performed.
COM0 to COM33	34	O	LCD	Common signals; those that are not used become non-selected waveforms. At 1/17 duty rate, COM1 to COM16 are used for character display, COM0 and COM17 for icon display, and COM18 to COM33 become non-selected waveforms. At 1/33 duty rate, COM1 to COM32 are used for character display, and COM0 and COM33 for icon display. Because two COM signals output the same level simultaneously, apply them according to the wiring pattern of the display device.
SEG1 to SEG60	60	O	LCD	Segment output signals

---

## HD66712U

**Table 1 Pin Functional Description (cont)**

Signal	Number of Pins	I/O	Device Interfaced with	Function
CL1	1	O	Extension driver	When EXT = high, outputs the extension driver latch pulse.
CL2	1	O	Extension driver	When EXT = high, outputs the extension driver shift clock.
D	1	O	Extension driver	When EXT = high, outputs extension driver data; data from the 61st dot on is output.
M	1	O	Extension driver	When EXT = high, outputs the extension driver AC signal.
EXT	1	I	—	When EXT = high, outputs the extension driver control signal. When EXT = low, the signal becomes tristate and can suppress consumption current.
V1 to V5	5	—	Power supply	Power supply for LCD drive $V_{cc} - V5 = 11V$ (max)
$V_{cc}$ /GND	2	—	Power supply	$V_{cc}$ : +2.7V to +5.5V, GND: 0V
OSC1/ OSC2	2	—	Oscillation resistor clock	When crystal oscillation is performed, an external resistor must be connected. When the pin input is an external clock, it must be input to OSC1.
Vci	1	I	—	Inputs voltage to the booster to generate the liquid crystal display drive voltage. Vci is reference voltage and power supply for the booster. $V_{ci} = 1.0V \text{ to } 5.0V \leq V_{cc}$
V5OUT2	1	O	V5 pin/ booster capacitance	Voltage input to the Vci pin is boosted twice and output. When the voltage is boosted three times, the same capacitance as that of C1–C2 should be connected here.
V5OUT3	1	O	V5 pin	Voltage input to the Vci pin is boosted three times and output.
C1/C2	2	—	Booster capacitance	External capacitance should be connected here when using the booster.
RESET*	1	I	—	Reset pin. Initialized to “low.”
TEST	1	I	—	Test pin. Should be wired to ground.

## **Function Description**

### **System Interface**

The HD66712 has three types of system interfaces: synchronized serial, 4-bit bus, and 8-bit bus. The serial interface is selected by the IM-pin, and the 4/8-bit bus interface is selected by the DL bit in the instruction register.

The HD66712 has two 8-bit registers: an instruction register (IR) and a data register (DR).

The IR stores instruction codes, such as display clear and cursor shift, and address information for the display data RAM (DDRAM), the character generator RAM (CGRAM), and the segment RAM (SEGRAM). The MPU can only write to IR, and cannot be read from.

The DR temporarily stores data to be written into DDRAM, CGRAM, or SEGRAM. Data written into the DR from the MPU is automatically written into DDRAM, CGRAM, or SEGRAM by an internal operation. The DR is also used for data storage when reading data from DDRAM, CGRAM, or SEGRAM. When address information is written into the IR, data is read and then stored into the DR from DDRAM or CGRAM by an internal operation. Data transfer between the MPU is then completed when the MPU reads the DR. After the read, data in DDRAM, CGRAM, or SEGRAM at the next address is sent to the DR for the next read from the MPU.

These two registers can be selected by the register selector (RS) signal in the 4/8 bit bus interface, and by the RS bit in start byte data in synchronized serial interface (Table 2).

### **Busy Flag (BF)**

When the busy flag is 1, the HD66712 is in the internal operation mode, and the next instruction will not be accepted. When  $RS = 0$  and  $R/W = 1$  (Table 2), the busy flag is output from DB7. The next instruction must be written after ensuring that the busy flag is 0.

### **Address Counter (AC)**

The address counter (AC) assigns addresses to DDRAM, CGRAM, or SEGRAM. When an address of an instruction is written into the IR, the address information is sent from the IR to the AC. Selection of DDRAM, CGRAM, and SEGRAM is also determined concurrently by the instruction.

After writing into (reading from) DDRAM, CGRAM, or SEGRAM, the AC is automatically incremented by 1 (decremented by 1). The AC contents are then output to DB0 to DB6 when  $RS = 0$  and  $R/\overline{W} = 1$  (Table 2).

---

## HD66712U

---

**Table 2 Resistor Selection**

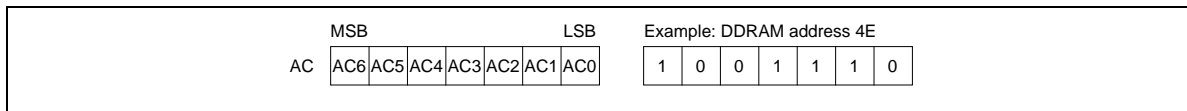
RS	R/W	Operation
0	0	IR write as an internal operation (display clear, etc.)
0	1	Read busy flag (DB7) and address counter (DB0 to DB6)
1	0	DR write as an internal operation (DR to DDRAM, CGRAM, or SEGRAM)
1	1	DR read as an internal operation (DDRAM, CGRAM, or SEGRAM to DR)

### Display Data RAM (DDRAM)

Display data RAM (DDRAM) stores display data represented in 8-bit character codes. Its capacity is  $80 \times 8$  bits, or 80 characters. The area in display data RAM (DDRAM) that is not used for display can be used as general data RAM.

The DDRAM address ( $A_{DD}$ ) is set in the address counter (AC) as a hexadecimal number, as shown in Figure 1.

The relationship between DDRAM addresses and positions on the liquid crystal display is described and shown on the following pages for a variety of cases.



**Figure 1 DDRAM Address**

- 1-line display (N = 0, and NW = 0)
  - Case 1: When there are fewer than 80 display characters, the display begins at the beginning of DDRAM. For example, when 24 5-dot font-width characters are displayed using one HD66712, the display is generated as shown in Figure 2.

When a display shift is performed, the DDRAM addresses shift as well as shown in the figure.

When 20 6-dot font-width characters are displayed using one HD66712, the display is generated as shown in Figure 3. Note that COM9 to COM16 begins at address (0A)H in this case 20 characters are displayed.

When a display shift is performed, the DDRAM addresses shift as well as shown in the figure.

- Case 2: Figure 4 shows the case where the EXT pin is fixed high and the HD66712 and the 40-output extension driver are used to display 24 6-dot font-width characters. In this case, COM9 to COM16 begins at (0A)H.

When a display shift is performed, the DDRAM addresses shift as well as shown in the figure.

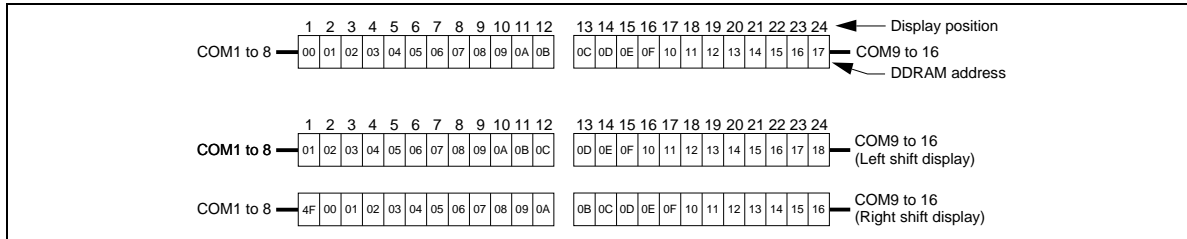


Figure 2 1-Line by 24-Character Display (5-Dot Font Width)

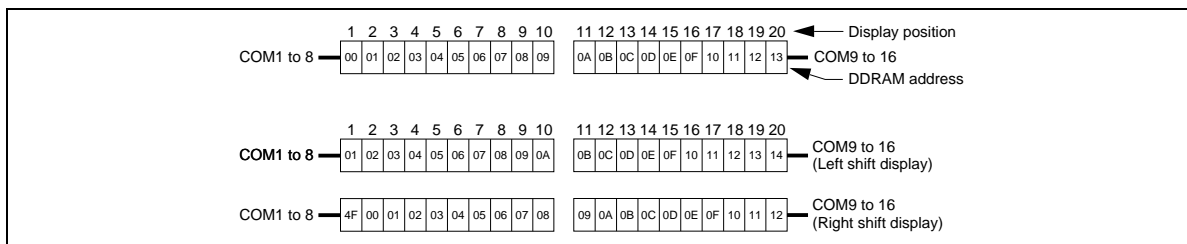
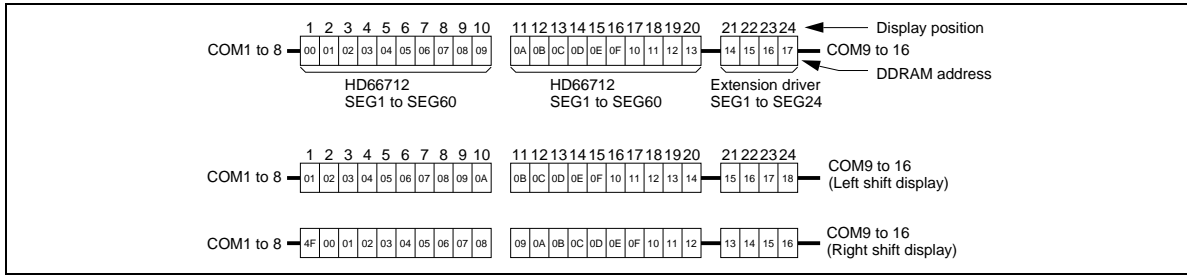


Figure 3 1-Line by 20-Character Display (6-Dot Font Width)

# HD66712U



**Figure 4 1-Line by 24-Character Display (6-Dot Font Width)**

- 2-line display (N = 1, and NW = 0)
  - Case 1: The first line is displayed from COM1 to COM16, and the second line is displayed from COM17 to COM32. Note that the last address of the first line and the first address of the second line are not consecutive. Figure 5 shows an example where a 5-dot font-width 24 × 2-line display is performed using one HD66712. Here, COM9 to COM16 begins at (0C)H, and COM25 to COM32 at (4C)H. When a display shift is performed, the DDRAM addresses shift as shown. Figure 6 shows an example where a 6-dot font-width 20 × 2-line display is performed using one HD66712. COM9 to COM16 begins at (0A)H, and COM25 to COM32 at (4A)H.



Figure 5 2-Line by 24-Character Display (5-Dot Font Width)

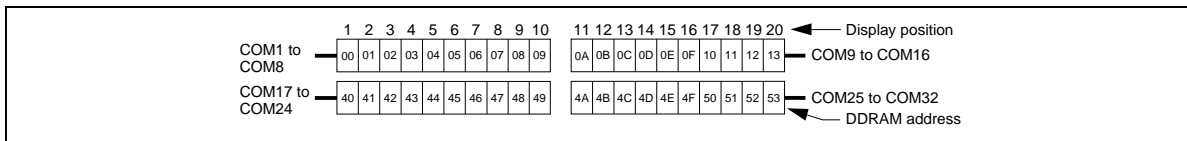


Figure 6 2-Line by 20-Character Display (6-Dot Font Width)

## HD66712U

- Case 2: Figure 7 shows the case where the EXT pin is fixed high and the HD66712 and the 40-output extension driver are used to extend the number of display characters to 32 5-dot font-width characters.

In this case, COM9 to COM16 begins at (0C)H, and COM25 to COM32 at (4C)H.

When a display shift is performed, the DDRAM addresses shift as shown.

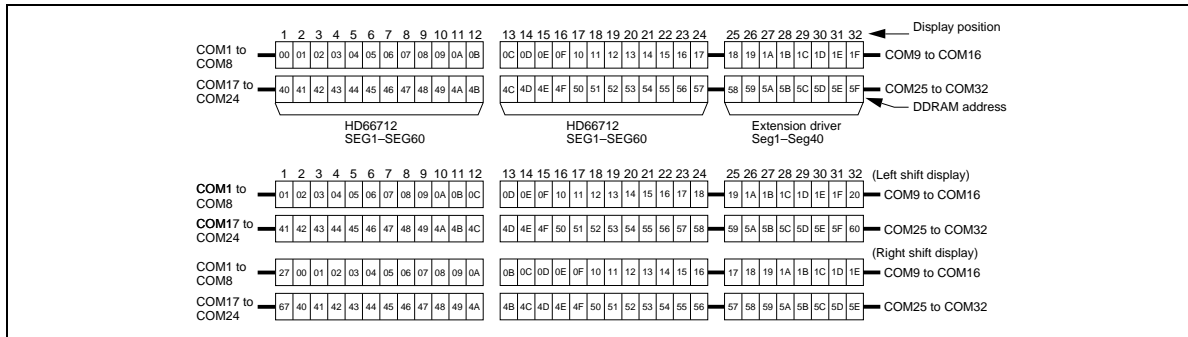


Figure 7 2-Line by 32 Character Display (5-Dot Font Width)

- 4-line display (NW = 1)

— Case 1: The first line is displayed from COM1 to COM8, the second line is displayed from COM9 to COM16, the third line is displayed from COM17 to COM24, and the fourth line is displayed from COM25 to COM32.

Note that the DDRAM addresses of each line are not consecutive. Figure 8 shows an example where a 12 × 4-line display is performed using one HD66712.

When a display shift is performed, the DDRAM addresses shift as shown.

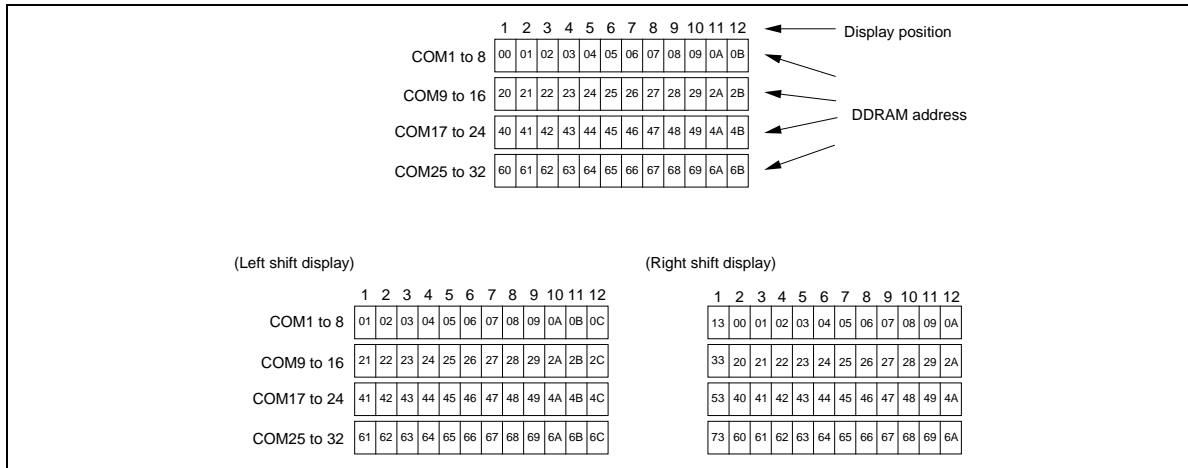
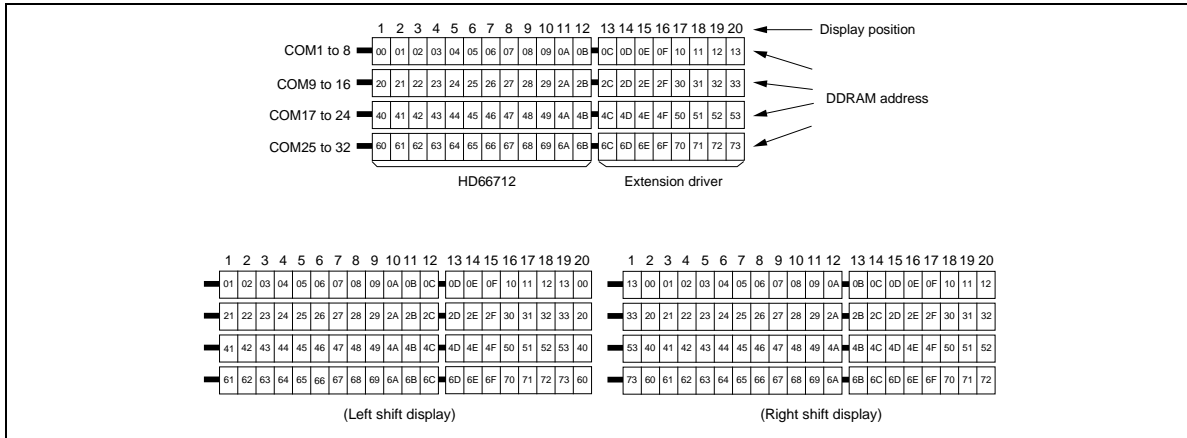


Figure 8 4-Line Display

# HD66712U

- Case 2: Figure 9 shows the case where the EXT pin is fixed high and the HD66712 and the 40-output extension driver are used to extend the number of display characters. When a display shift is performed, the DDRAM addresses shift as shown.



**Figure 9 4-Line by 20-Character Display**

### **Character Generator ROM (CGROM)**

The character generator ROM generates  $5 \times 8$  dot character patterns from 8-bit character codes (Table 3 to 6). It can generate 240  $5 \times 8$  dot character patterns. User-defined character patterns are also available using a mask-programmed ROM (see “Modifying Character Patterns.”)

### **Character Generator RAM (CGRAM)**

The character generator RAM allows the user to redefine the character patterns. In the case of  $5 \times 8$  characters, up to eight may be redefined.

Write the character codes at the addresses shown as the left column of Table 3 to 6 to show the character patterns stored in CGRAM.

See Table 7 for the relationship between CGRAM addresses and data and display patterns.

### **Segment RAM (SEGRAM)**

The segment RAM (SEGRAM) is used to enable control of segments such as an icon and a mark by the user program.

For a 1-line display, SEGRAM is read from the COM0 and the COM17 output, and for 2- or 4-line displays, it is read from the COM0 and the COM33 output, to perform 60-segment display (80-segment display when using the extension driver).

As shown in Table 8, bits in SEGRAM corresponding to segments to be displayed are directly set by the MPU, regardless of the contents of DDRAM and CGRAM.

SEGRAM data is stored in eight bits. The lower six bits control the display of each segment, and the upper two bits control segment blinking.

### **Timing Generation Circuit**

The timing generation circuit generates timing signals for the operation of internal circuits such as DDRAM, CGROM, CGRAM, and SEGRAM. RAM read timing for display and internal operation timing by MPU access are generated separately to avoid interfering with each other. Therefore, when writing data to DDRAM, for example, there will be no undesirable interferences, such as flickering, in areas other than the display area.

---

## HD66712U

---

### Liquid Crystal Display Driver Circuit

The liquid crystal display driver circuit consists of 34 common signal drivers and 60 segment signal drivers. When the character font and number of lines are selected by a program, the required common signal drivers automatically output drive waveforms, while the other common signal drivers continue to output non-selection waveforms.

Character pattern data is sent serially through a 60-bit shift register and latched when all needed data has arrived. The latched data then enables the driver to generate drive waveform outputs.

Sending serial data always starts at the display data character pattern corresponding to the last address of the display data RAM (DDRAM).

Since serial data is latched when the display data character pattern corresponding to the starting address enters the internal shift register, the HD66712 drives from the head display.

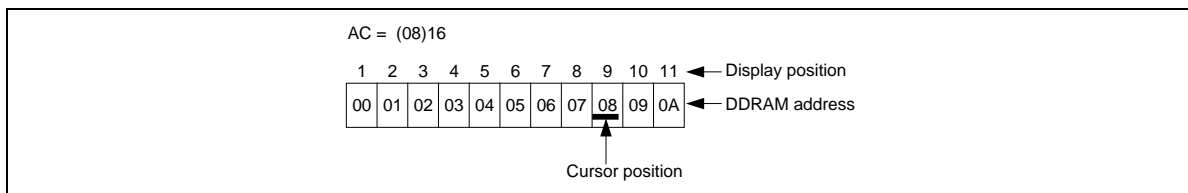
### Cursor/Blink Control Circuit

The cursor/blink (or white-black inversion) control is used to produce a cursor or a flashing area on the display at a position corresponding to the location in stored in the address counter (AC).

For example (Figure 10), when the address counter is (08)H, a cursor is displayed at a position corresponding to DDRAM address (08)H.

### Scroll Control Circuit

The scroll control circuit is used to perform a smooth-scroll in the unit of dot. When the number of characters to be displayed is greater than that possible at one time on the liquid crystal module, this horizontal smooth scroll can be used to display all characters.



**Figure 10 Cursor/Blink Display Example**

Table 3 Relationship between Character Codes and Character Patterns (ROM Code: A00)

Lower Bits \ Upper Bits	0000	0001	0010	0011	0100	0101	0110	0111	1000	1001	1010	1011	1100	1101	1110	1111
xxxx0000	CG RAM (1)			0	a	P	`	P				-	9	3	0	0
xxxx0001	CG RAM (2)		!	1	A	Q	a	9			a	7	7	4	a	Q
xxxx0010	CG RAM (3)		"	2	B	R	b	r			"	イ	ツ	×	0	0
xxxx0011	CG RAM (4)		#	3	C	S	c	s			」	ウ	テ	E	e	o
xxxx0100	CG RAM (5)		\$	4	D	T	d	t			、	エ	ト	ハ	ウ	0
xxxx0101	CG RAM (6)		%	5	E	U	e	u			・	オ	ナ	1	0	0
xxxx0110	CG RAM (7)		&	6	F	V	f	v			ヲ	カ	ニ	ヨ	0	Σ
xxxx0111	CG RAM (8)		'	7	G	W	g	w			フ	キ	ヌ	ラ	Q	π
xxxx1000	CG RAM (1)		(	8	H	X	h	x			イ	ウ	ネ	リ	ル	Σ
xxxx1001	CG RAM (2)		)	9	I	Y	i	y			ウ	ク	ル	レ	U	
xxxx1010	CG RAM (3)		*	:	J	Z	j	z			エ	コ	ハ	レ	i	♀
xxxx1011	CG RAM (4)		+	;	K	C	k	<			オ	ウ	ヒ	ロ	*	π
xxxx1100	CG RAM (5)		,	<	L	≠	l	l			ハ	シ	フ	ワ	0	π
xxxx1101	CG RAM (6)		-	=	M	J	m	>			ユ	ズ	ハ	ン	レ	÷
xxxx1110	CG RAM (7)		.	>	N	^	n	→			ヨ	セ	ホ	レ	ñ	
xxxx1111	CG RAM (8)		/	?	O	_	o	←			ウ	ソ	マ	°	0	■

Table 4 Relationship between Character Codes and Character Pattern (ROM Code: A01)

Lower Bits \ Upper Bits	0000	0001	0010	0011	0100	0101	0110	0111	1000	1001	1010	1011	1100	1101	1110	1111
xxxx0000	CG RAM (1)	á	â	ã	ä	å	æ	ç	è	é	ê	ë	ì	í	î	ï
xxxx0001	CG RAM (2)	í	! 1	â	Q	a	9	û	æ	»	7	* 4	日	7		
xxxx0010	CG RAM (3)	ó	" 2	B	R	b	r	é	ê	ë	í	ú	×	分	ウ	
xxxx0011	CG RAM (4)	ú	# 3	C	S	c	s	â	ô	¸	ウ	て	モ	用	て	
xxxx0100	CG RAM (5)	ñ	\$ 4	D	T	d	t	ä	ö	¸	工	ト	ト	ト	ト	
xxxx0101	CG RAM (6)	ñ	% 5	E	U	e	u	à	ò	¸	オ	カ	コ	コ	コ	
xxxx0110	CG RAM (7)	ä	& 6	F	V	f	v	â	ô	¸	カ	ニ	コ	カ	カ	
xxxx0111	CG RAM (8)	ö	' 7	G	W	w	ç	ù	7	¸	又	又	又	又	又	
xxxx1000	CG RAM (1)	¿	( 8	H	X	h	x	ê	ô	¸	ウ	カ	リ	ウ	ウ	
xxxx1001	CG RAM (2)	ß	) 9	I	Y	i	y	è	ö	¸	ウ	ル	ウ	ル	ル	
xxxx1010	CG RAM (3)	M	* :	J	Z	j	z	è	ü	¸	コ	ロ	コ	ロ	ロ	
xxxx1011	CG RAM (4)	ø	+ ;	K	[	k	(	i	ト	¸	オ	サ	ヒ	ロ	サ	ヒ
xxxx1100	CG RAM (5)	é	, <	L	¥	l	l	î	金	¸	フ	フ	フ	フ	フ	
xxxx1101	CG RAM (6)	ì	- =	M	]	m	)	î	木	¸	ズ	ソ	ズ	ソ	ソ	
xxxx1110	CG RAM (7)	¸	, >	N	^	n	→	â	*	¸	ヨ	ト	ヨ	ト	ト	
xxxx1111	CG RAM (8)	¸	/ ?	O	_	o	←	â	火	¸	ソ	マ	ソ	マ	マ	

Table 5 Relationship between Character Codes and Character Patterns (ROM Code: A02)

Lower Bits \ Upper Bits	0000	0001	0010	0011	0100	0101	0110	0111	1000	1001	1010	1011	1100	1101	1110	1111
xxxx0000	CG RAM (1)	<b>!</b>	<b>0</b>	<b>1</b>	<b>2</b>	<b>3</b>	<b>4</b>	<b>5</b>	<b>6</b>	<b>7</b>	<b>8</b>	<b>9</b>	<b>A</b>	<b>B</b>	<b>C</b>	<b>D</b>
xxxx0001	CG RAM (2)	<b>E</b>	<b>F</b>	<b>G</b>	<b>H</b>	<b>I</b>	<b>J</b>	<b>K</b>	<b>L</b>	<b>M</b>	<b>N</b>	<b>O</b>	<b>P</b>	<b>Q</b>	<b>R</b>	<b>S</b>
xxxx0010	CG RAM (3)	<b>T</b>	<b>U</b>	<b>V</b>	<b>W</b>	<b>X</b>	<b>Y</b>	<b>Z</b>	<b>[</b>	<b>\</b>	<b>]</b>	<b>^</b>	<b>_</b>	<b>0</b>	<b>1</b>	<b>2</b>
xxxx0011	CG RAM (4)	<b>3</b>	<b>4</b>	<b>5</b>	<b>6</b>	<b>7</b>	<b>8</b>	<b>9</b>	<b>A</b>	<b>B</b>	<b>C</b>	<b>D</b>	<b>E</b>	<b>F</b>	<b>G</b>	<b>H</b>
xxxx0100	CG RAM (5)	<b>I</b>	<b>J</b>	<b>K</b>	<b>L</b>	<b>M</b>	<b>N</b>	<b>O</b>	<b>P</b>	<b>Q</b>	<b>R</b>	<b>S</b>	<b>T</b>	<b>U</b>	<b>V</b>	<b>W</b>
xxxx0101	CG RAM (6)	<b>X</b>	<b>Y</b>	<b>Z</b>	<b>[</b>	<b>\</b>	<b>]</b>	<b>^</b>	<b>_</b>	<b>0</b>	<b>1</b>	<b>2</b>	<b>3</b>	<b>4</b>	<b>5</b>	<b>6</b>
xxxx0110	CG RAM (7)	<b>7</b>	<b>8</b>	<b>9</b>	<b>A</b>	<b>B</b>	<b>C</b>	<b>D</b>	<b>E</b>	<b>F</b>	<b>G</b>	<b>H</b>	<b>I</b>	<b>J</b>	<b>K</b>	<b>L</b>
xxxx0111	CG RAM (8)	<b>M</b>	<b>N</b>	<b>O</b>	<b>P</b>	<b>Q</b>	<b>R</b>	<b>S</b>	<b>T</b>	<b>U</b>	<b>V</b>	<b>W</b>	<b>X</b>	<b>Y</b>	<b>Z</b>	<b>[</b>
xxxx1000	CG RAM (1)	<b>]</b>	<b>^</b>	<b>_</b>	<b>0</b>	<b>1</b>	<b>2</b>	<b>3</b>	<b>4</b>	<b>5</b>	<b>6</b>	<b>7</b>	<b>8</b>	<b>9</b>	<b>A</b>	<b>B</b>
xxxx1001	CG RAM (2)	<b>C</b>	<b>D</b>	<b>E</b>	<b>F</b>	<b>G</b>	<b>H</b>	<b>I</b>	<b>J</b>	<b>K</b>	<b>L</b>	<b>M</b>	<b>N</b>	<b>O</b>	<b>P</b>	<b>Q</b>
xxxx1010	CG RAM (3)	<b>R</b>	<b>S</b>	<b>T</b>	<b>U</b>	<b>V</b>	<b>W</b>	<b>X</b>	<b>Y</b>	<b>Z</b>	<b>[</b>	<b>\</b>	<b>]</b>	<b>^</b>	<b>_</b>	<b>0</b>
xxxx1011	CG RAM (4)	<b>1</b>	<b>2</b>	<b>3</b>	<b>4</b>	<b>5</b>	<b>6</b>	<b>7</b>	<b>8</b>	<b>9</b>	<b>A</b>	<b>B</b>	<b>C</b>	<b>D</b>	<b>E</b>	<b>F</b>
xxxx1100	CG RAM (5)	<b>G</b>	<b>H</b>	<b>I</b>	<b>J</b>	<b>K</b>	<b>L</b>	<b>M</b>	<b>N</b>	<b>O</b>	<b>P</b>	<b>Q</b>	<b>R</b>	<b>S</b>	<b>T</b>	<b>U</b>
xxxx1101	CG RAM (6)	<b>V</b>	<b>W</b>	<b>X</b>	<b>Y</b>	<b>Z</b>	<b>[</b>	<b>\</b>	<b>]</b>	<b>^</b>	<b>_</b>	<b>0</b>	<b>1</b>	<b>2</b>	<b>3</b>	<b>4</b>
xxxx1110	CG RAM (7)	<b>5</b>	<b>6</b>	<b>7</b>	<b>8</b>	<b>9</b>	<b>A</b>	<b>B</b>	<b>C</b>	<b>D</b>	<b>E</b>	<b>F</b>	<b>G</b>	<b>H</b>	<b>I</b>	<b>J</b>
xxxx1111	CG RAM (8)	<b>K</b>	<b>L</b>	<b>M</b>	<b>N</b>	<b>O</b>	<b>P</b>	<b>Q</b>	<b>R</b>	<b>S</b>	<b>T</b>	<b>U</b>	<b>V</b>	<b>W</b>	<b>X</b>	<b>Y</b>

Note: The character codes of the characters enclosed in the bold frame are the same as those of the first edition of the ISO8859 and the character code compatible.

Table 6 Relationship between Character Codes and Character Pattern (ROM Code: A03)

Lower Bits \ Upper Bits	0000	0001	0010	0011	0100	0101	0110	0111	1000	1001	1010	1011	1100	1101	1110	1111
xxxx0000	CG RAM (1)	ア		カ	キ	ク	ケ	コ	サ	シ	ス	セ	ソ	タ	チ	ツ
xxxx0001	CG RAM (2)	カ	!	1	ア	Q	a	9	U	æ	。	フ	チ	ク	ア	9
xxxx0010	CG RAM (3)	カ	"	2	E	R	b	r	é	E	!	ツ	×	β	θ	
xxxx0011	CG RAM (4)	カ	#	3	C	S	c	s	ä	ö	!	フ	テ	エ	。	
xxxx0100	CG RAM (5)	カ	\$	4	D	T	d	t	ä	ö	、	!	ト	ト	μ	Ω
xxxx0101	CG RAM (6)	カ	%	5	E	U	e	u	ä	ö	。	!	!	!	!	!
xxxx0110	CG RAM (7)	カ	&	6	F	U	f	v	ä	ö	!	!	!	!	!	!
xxxx0111	CG RAM (8)	カ	'	7	G	W	w	ç	ü	!	!	!	!	!	!	!
xxxx1000	CG RAM (1)	カ	(	8	H	X	h	x	é	ü	!	!	!	!	!	!
xxxx1001	CG RAM (2)	カ	)	9	I	Y	i	y	é	ö	!	!	!	!	!	!
xxxx1010	CG RAM (3)	カ	*	:	J	Z	j	z	è	ü	!	!	!	!	!	!
xxxx1011	CG RAM (4)	カ	+	;	K	L	k	l	!	!	!	!	!	!	!	!
xxxx1100	CG RAM (5)	カ	,	<	L	!	!	!	!	!	!	!	!	!	!	!
xxxx1101	CG RAM (6)	カ	-	=	M	I	m	)	!	!	!	!	!	!	!	!
xxxx1110	CG RAM (7)	カ	.	>	N	^	n	!	!	!	!	!	!	!	!	!
xxxx1111	CG RAM (8)	カ	/	?	O	_	o	!	!	!	!	!	!	!	!	!

**Table 7 Example of Relationships between Character Code (DDRAM) and Character Pattern(CGRAM Data)**

**a) When character pattern is 5 × 8 dots**

Character code (DDRAM data)								CGRAM address			MSB	CGRAM data								LSB		
D7	D6	D5	D4	D3	D2	D1	D0	A5	A4	A3	A2	A1	A0	O7	O6	O5	O4	O3	O2	O1	O0	
0	0	0	0	*	0	0	0	0	0	0	0	0	0	*	*	*	1	0	0	0	1	Character pattern (1)
																	1	0	0	0	1	
																	1	0	0	0	1	
																	0	1	0	1	0	
																	0	0	1	0	0	
																	0	0	1	0	0	
																	0	0	1	0	0	
																	0	0	1	0	0	
0	0	0	0	*	1	1	1	1	1	1	0	0	0	*	*	*	1	0	0	0	1	Character pattern (8)
																	1	0	0	0	1	
																	1	0	0	0	1	
																	0	1	0	1	0	
																	0	0	1	0	0	
																	0	0	1	0	0	
																	0	0	1	0	0	
																	0	0	1	0	0	

**a) When character pattern is 6 × 8 dots**

Character code (DDRAM data)								CGRAM address			MSB	CGRAM data								LSB			
D7	D6	D5	D4	D3	D2	D1	D0	A5	A4	A3	A2	A1	A0	O7	O6	O5	O4	O3	O2	O1	O0		
0	0	0	0	*	0	0	0	0	0	0	0	0	0	*	*	0	1	0	0	0	1	Character pattern (1)	
																	0	1	0	0	0		1
																	0	1	0	0	0		1
																	0	0	1	0	1		0
																	0	0	0	1	0		0
																	0	0	0	1	0		0
																	0	0	0	1	0		0
																	0	0	0	1	0		0
0	0	0	0	*	1	1	1	1	1	1	0	0	0	*	*	0	1	0	0	0	1	Character pattern (8)	
																	0	1	0	0	0		1
																	0	1	0	0	0		1
																	0	0	1	0	1		0
																	0	0	0	1	0		0
																	0	0	0	1	0		0
																	0	0	0	1	0		0
																	0	0	0	1	0		0

---

## HD66712U

---

- Notes:
1. Character code bits 0 to 2 correspond to CGRAM address bits 3 to 5 (3 bits: 8 types).
  2. CGRAM address bits 0 to 2 designate the character pattern line position. The 8th line is the cursor position and its display is formed by a logical OR with the cursor.
  3. The character data is stored with the rightmost character element in bit 0, as shown in the figure above. Characters of 5 dots in width (FW = 0) are stored in bits 0 to 4, and characters of 6 dots in width (FW = 1) are stored in bits 0 to 5.
  4. When the upper four bits (bits 7 to 4) of the character code are 0, CGRAM is selected.  
Bit 3 of the character code is invalid (\*). Therefore, for example, the character codes (00)H and (08)H correspond to the same CGRAM address.
  5. A set bit in the CGRAM data corresponds to display selection, and 0 to non-selection.
  6. When the BE bit of the function set register is 1, pattern blinking control of the lower six bits is controlled using the upper two bits (bits 7 and 6) in CGRAM.  
When bit 7 is 1, of the lower six bits, only those which are set are blinked on the display.  
When bit 6 is 1, a bit 4 pattern can be blinked as for a 5-dot font width, and a bit 5 pattern can be blinked as for a 6-dot font width.
- \* Indicates no effect.

**Table 8 Relationship between SEGRAM Addresses and Display Patterns**

SEGRAM address				SEGRAM data															
				a) 5-dot font width								b) 6-dot font width							
A3	A2	A1	A0	D7	D6	D5	D4	D3	D2	D1	D0	D7	D6	D5	D4	D3	D2	D1	D0
0	0	0	0	B1	B0	*	S1	S2	S3	S4	S5	B1	B0	S1	S2	S3	S4	S5	S6
0	0	0	1	B1	B0	*	S6	S7	S8	S9	S10	B1	B0	S7	S8	S9	S10	S11	S12
0	0	1	0	B1	B0	*	S11	S12	S13	S14	S15	B1	B0	S13	S14	S15	S16	S17	S18
0	0	1	1	B1	B0	*	S16	S17	S18	S19	S20	B1	B0	S19	S20	S21	S22	S23	S24
0	1	0	0	B1	B0	*	S21	S22	S23	S24	S25	B1	B0	S25	S26	S27	S28	S29	S30
0	1	0	1	B1	B0	*	S26	S27	S28	S29	S30	B1	B0	S31	S32	S33	S34	S35	S36
0	1	1	0	B1	B0	*	S31	S32	S33	S34	S35	B1	B0	S37	S38	S39	S40	S41	S42
0	1	1	1	B1	B0	*	S36	S37	S38	S39	S40	B1	B0	S43	S44	S45	S46	S47	S48
1	0	0	0	B1	B0	*	S41	S42	S43	S44	S45	B1	B0	S49	S50	S51	S52	S53	S54
1	0	0	1	B1	B0	*	S46	S47	S48	S49	S50	B1	B0	S55	S56	S57	S58	S59	S60
1	0	1	0	B1	B0	*	S51	S52	S53	S54	S55	B1	B0	S61	S62	S63	S64	S65	S66
1	0	1	1	B1	B0	*	S56	S57	S58	S59	S60	B1	B0	S67	S68	S69	S70	S71	S72
1	1	0	0	B1	B0	*	S61	S62	S63	S64	S65	B1	B0	S73	S74	S75	S76	S77	S78
1	1	0	1	B1	B0	*	S66	S67	S68	S69	S70	B1	B0	S79	S80	S81	S82	S83	S84
1	1	1	0	B1	B0	*	S71	S72	S73	S74	S75	B1	B0	S85	S86	S87	S88	S89	S90
1	1	1	1	B1	B0	*	S76	S77	S78	S79	S80	B1	B0	S91	S92	S93	S94	S95	S96

Blinking control
Pattern on/off
Blinking control
Pattern on/off

- Notes:
1. Data set to SEGRAM is output when COM0 and COM17 are selected, as for a 1-line display, and output when COM0 and COM33 are selected, as for a 2-line or a 4-line display. COM0 and COM17 for a 1-line display and COM0 and COM33 for a 2-line or a 4-line display are the same signals.
  2. S1 to S96 are pin numbers of the segment output driver. S1 is positioned to the left of the display. When the HD66712 is used by one chip, segments from S1 to S60 are displayed. An extension driver displays the segments after S61.
  3. After S80 output at 5-dot font and S96 output at 6-dot font, S1 output is repeated again.
  4. As for a 5-dot font width, lower five bits (D4 to D0) are display on.off information of each segment. For a 6-dot character width, the lower six bits (D5 to D0) are the display information for each segment.
  5. When the BE bit of the function set register is 1, pattern blinking of the lower six bits is controlled using the upper two bits (bits 7 and 6) in SEGRAM.  
 When bit 7 is 1, only a bit set to "1" of the lower six bits is blinked on the display.  
 When bit 6 is 1, only a bit 4 pattern can be blinked as for a 5-dot font width, and only a bit 5 pattern can be blinked as for 6-dot font width.
  6. Bit 5 (D5) is invalid for a 5-dot font width.
  7. Set bits in the SEGRAM data correspond to display selection, and zeros to non-selection.

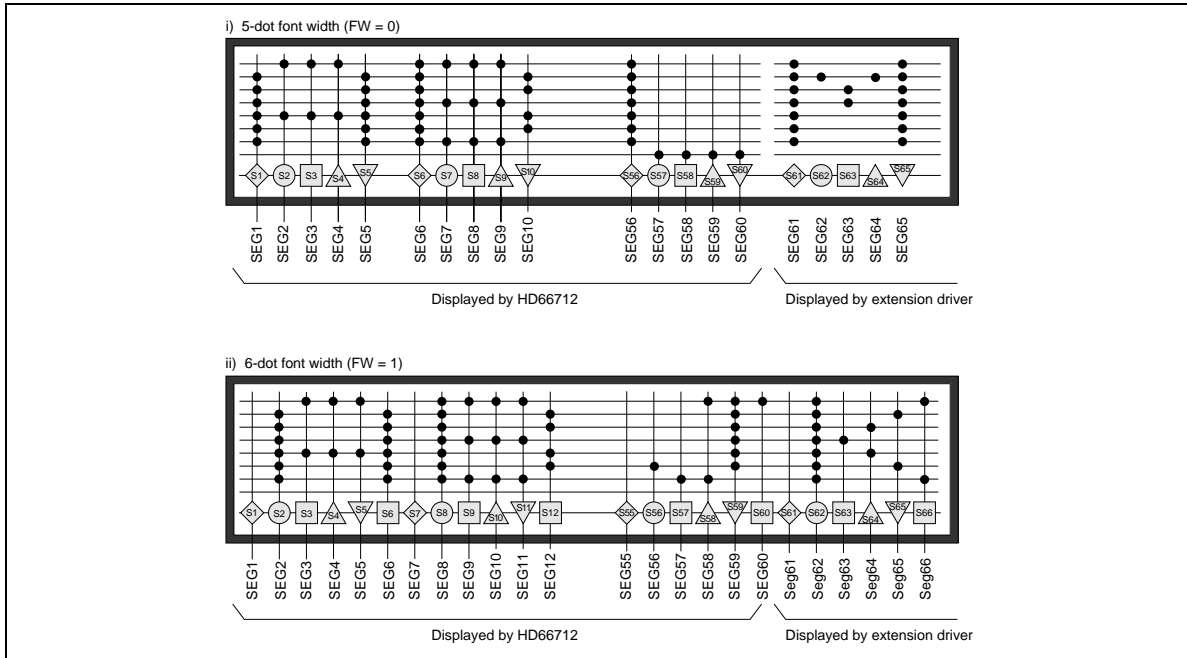


Figure 11 Correspondence between SEGRAM and Segment Display

### **Modifying Character Patterns**

- Character pattern development procedure

The following operations correspond to the numbers listed in Figure 12:

- a. Determine the correspondence between character codes and character patterns.
- b. Create a listing indicating the correspondence between EPROM addresses and data.
- c. Program the character patterns into an EPROM.
- d. Send the EPROM to Hitachi.
- e. Computer processing of the EPROM is performed at Hitachi to create a character pattern listing, which is sent to the user.
- f. If there are no problems within the character pattern listing, a trial LSI is created at Hitachi and samples are sent to the user for evaluation. When it is confirmed by the user that the character patterns are correctly written, mass production of the LSI will proceed at Hitachi.

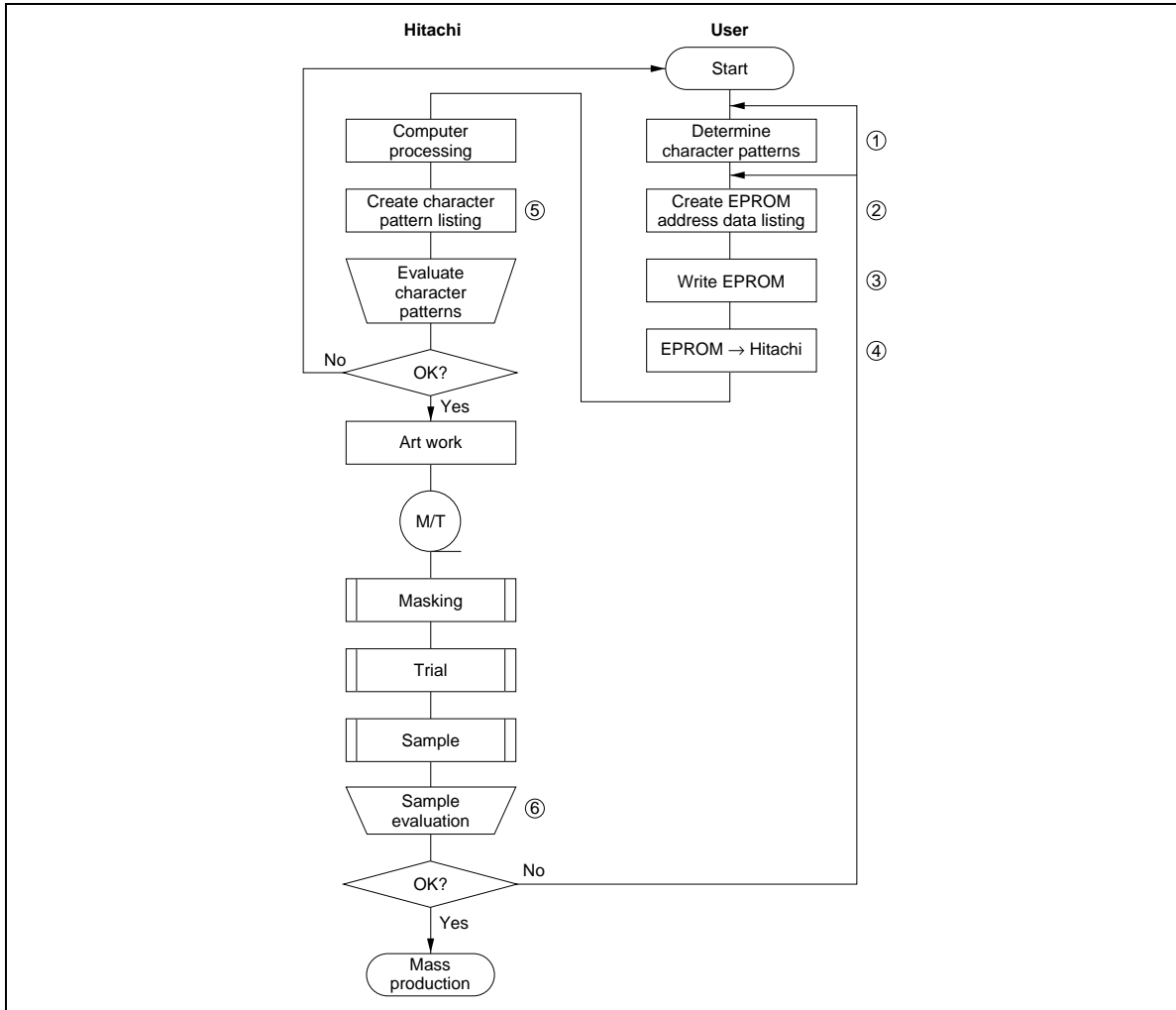


Figure 12 Character Pattern Development Procedure

**Programming Character Patterns**

This section explains the correspondence between addresses and data used to program character patterns in EPROM.

- Programming to EPROM

The HD66712 character generator ROM can generate 240 5 × 8 dot character patterns. Table 9 shows correspondence between the EPROM address data and the character pattern.

**Handling Unused Character Patterns**

1. EPROM data outside the character pattern area: This is ignored by the character generator ROM for display operation so any data is acceptable.
2. EPROM data in CGRAM area: Always fill with zeros.
3. Treatment of unused user patterns in the HD66712 EPROM: According to the user application, these are handled in either of two ways:
  - a. When unused character patterns are not programmed: If an unused character code is written into DDRAM, all its dots are lit, because the EPROM is filled with 1s after it is erased.
  - b. When unused character patterns are programmed as 0s: Nothing is displayed even if unused character codes are written into DDRAM. (This is equivalent to a space.)

**Table 9 Example of Correspondence between EPROM Address Data and Character Pattern (5 × 8 Dots)**

EPROM Address										Data						
A11	A10	A9	A8	A7	A6	A5	A4	A3	A2	A1	A0	MSB	Data			LSB
										O4	O3	O2	O1	O0		
0	1	0	1	1	0	0	1	0	0	0	0	1	0	0	0	1
								0	0	0	1	1	0	0	0	1
								0	0	1	0	1	0	0	0	1
								0	0	1	1	0	1	0	1	0
								0	1	0	0	0	0	1	0	0
								0	1	0	1	0	0	1	0	0
								0	1	1	0	0	0	1	0	0
								0	1	1	1	0	0	0	0	0

Character code
"0" Line position

- Notes:
1. EPROM addresses A11 to A4 correspond to a character code.
  2. EPROM addresses A2 to A0 specify the line position of the character pattern. EPROM address A3 should be set to "0."
  3. EPROM data O4 to O0 correspond to character pattern data.
  4. Areas which are lit (indicated by shading) are stored as "1," and unlit areas as "0."
  5. The eighth line is also stored in the CGROM, and should also be programmed. If the eighth line is used for a cursor, this data should all be set to zero.
  6. EPROM data bits O7 to O5 are invalid. 0 should be written in all bits.

## Reset Function

### Initializing by Internal Reset Circuit

An internal reset circuit automatically initializes the HD66712 when the power is turned on. The following instructions are executed during the initialization. The busy flag (BF) is kept in the busy state until the initialization ends (BF = 1). The busy state lasts for 15 ms after  $V_{CC}$  rises to 4.5V or 40 ms after the  $V_{CC}$  rises to 2.7V.

1. Display clear:  
(20)H to all DDRAM
2. Set functions:  
DL = 1: 8-bit interface data  
N = 1: 2-line display  
RE = 0: Extension register write disable  
BE = 0: CGRAM/SEGRAM blink off  
LP = 0: Not in low power mode
3. Control display on/off:  
D = 0: Display off  
C = 0: Cursor off  
B = 0: Blinking off
4. Set entry mode:  
I/D = 1: Increment by 1  
S = 0: No shift
5. Set extension function:  
FW = 0: 5-dot character width  
B/W = 0: Normal cursor (eighth line)  
NW = 0: 1- or 2-line display (depending on N)
6. Enable scroll:  
HSE = 0000: Scroll unable
7. Set scroll amount:  
HDS = 000000: Not scroll

Note: If the electrical characteristics conditions listed under the Table Power Supply Conditions Using Internal Reset Circuit are not met, the internal reset circuit will not operate normally and will fail to initialize the HD66712.

### Initializing by Hardware Reset Input

The HD66712 also has a reset input pin: RESET\*. If this pin is made low during operation, an internal reset and initialization is performed. This pin is ignored, however, during the internal reset period at power-on.

### Interfacing to the MPU

The HD66712 can send data in either two 4-bit operations or one 8-bit operation, thus allowing interfacing with 4- or 8-bit MPUs.

- For 4-bit interface data, only four bus lines (DB4 to DB7) are used for transfer. Bus lines DB0 to DB3 are disabled. The data transfer between the HD66712 and the MPU is completed after the 4-bit data has been transferred twice. As for the order of data transfer, the four high order bits (for 8-bit operation, DB4 to DB7) are transferred before the four low order bits (for 8-bit operation, DB0 to DB3).

The busy flag must be checked (one instruction) after the 4-bit data has been transferred twice. Two more 4-bit operations then transfer the busy flag and address counter data.

- For 8-bit interface data, all eight bus lines (DB0 to DB7) are used.
- When the IM pin is low, the HD66712 uses a serial interface. See “Transferring Serial Data.”

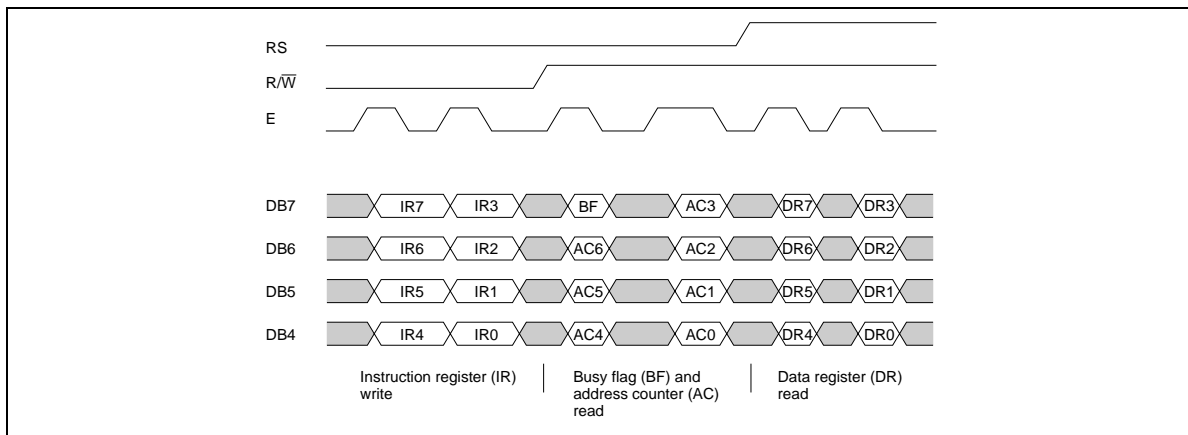


Figure 13 4-Bit Transfer Example

---

## HD66712U

---

### Transferring Serial Data

When the IM pin (interface mode) is low, the HD66712 enters serial interface mode. A three-line clock-synchronous transfer method is used. The HD66712 receives serial input data (SID) and transmits serial output data (SOD) by synchronizing with a transfer clock (SCLK) sent from the master side.

When the HD66712 interfaces with several chips, chip select pin (CS\*) must be used. The transfer clock (SCLK) input is activated by making chip select (CS\*) low. In addition, the transfer counter of the HD66712 can be reset and serial transfer synchronized by making chip select (CS\*) high.

Here, since the data which was being sent at reset is cleared, restart the transfer from the first bit of this data. In the case of a minimum 1 to 1 transfer system with the HD66712 used as a receiver only, an interface can be established by the transfer clock (SCLK) and serial input data (SID). In this case, chip select (CS\*) should be fixed to low.

The transfer clock (SCLK) is independent from operational clock (CLK) of the HD66712. However, when several instructions are continuously transferred, the instruction execution time determined by the operational clock (CLK) (see continuous transfer) must be considered since the HD66712 does not have an internal transmit/receive buffer.

To begin with, transfer the start byte. By receiving five consecutive bits (synchronizing bit string) at the beginning of the start byte, the transfer counter of the HD66712 is reset and serial transfer is synchronized. The 2 bits following the synchronizing bit string (5 bits) specify transfer direction ( $R/\overline{W}$  bit) and register select (RS bit). Be sure to transfer 0 in the 8th bit.

After receiving the start byte, instructions are received and the data/busy flag is transmitted. When the transfer direction and register select remain the same, data can be continuously transmitted or received.

The transfer protocol is described in detail below.

- Receiving (write)

After receiving the start synchronization bits, the  $R/\overline{W}$  bit (= 0), and the RS bit with the start byte, an 8-bit instruction is received in 2 bytes: the lower 4 bits of the instruction are placed in the LSB of the first byte, and the higher 4 bits of the instruction are placed in the LSB of the second byte. Be sure to transfer 0 in the following 4 bits of each byte. When instructions are continuously received with  $R/\overline{W}$  bit and RS bit unchanged, continuous transfer is possible (see “Continuous Transfer” below).

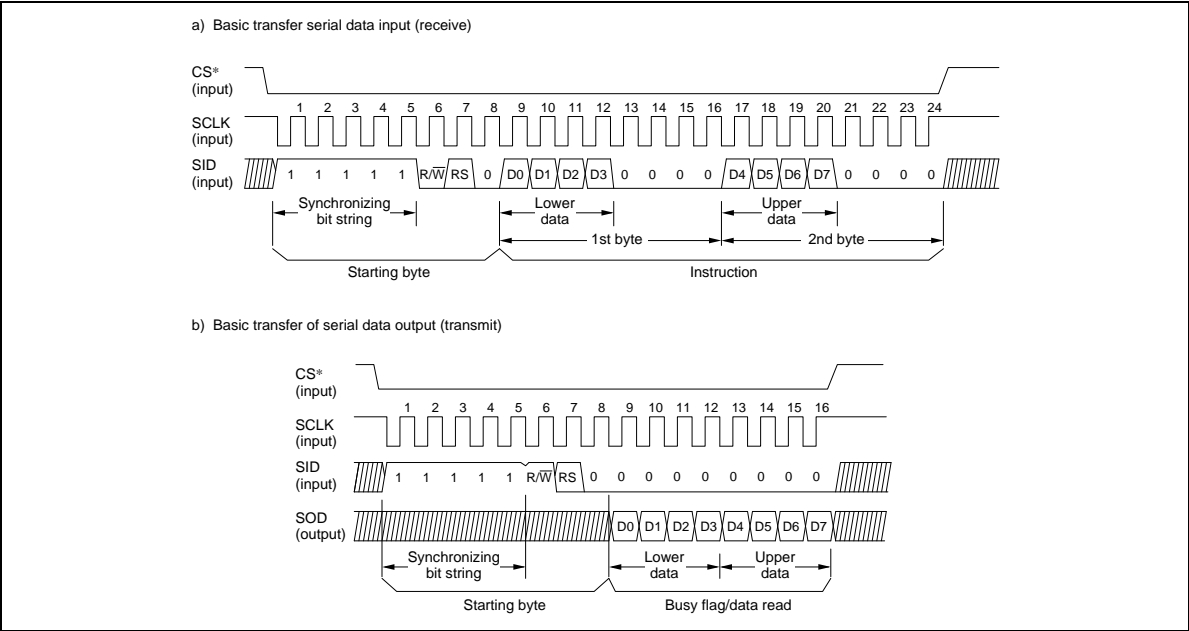


Figure 14 Basic Procedure for Transferring Serial Data

---

## HD66712U

---

- Transmitting (read)

After receiving the start synchronization bits, the  $R/\overline{W}$  bit (= 1), and the RS bit with the start byte, 8-bit read data is transmitted in the same way as receiving. When read data is continuously transmitted with  $R/\overline{W}$  bit and RS bit unchanged, continuous transfer is possible (see “Continuous Transfer” below).

Even at the time of the transmission (the data output), since the HD66712 monitors the start synchronization bit string (“11111”) by the SID input, the HD66712 receives the R/W bit and RS bit after detecting the start synchronization. Therefore, in the case of a continuous transfer, fix the SID input “0.”

- Continuous transfer

When instructions are continuously received with the  $R/\overline{W}$  bit and RS bit unchanged, continuous receive is possible without inserting a start byte between instructions.

After receiving the last bit (the 8th bit in the 2nd byte) of an instruction, the system begins to execute it.

To execute the next instruction, the instruction execution time of the HD66712 must be considered. If the last bit (the 8th bit in the 2nd byte) of the next instruction is received during execution of the previous instruction, the instruction will be ignored.

In addition, if the next unit of data is read before read execution of previous data is completed for busy flag/address counter/RAM data, normal data is not sent. To transfer data normally, the busy flag must be checked. However, it is possible to transfer without reading the busy flag if wiring for transmission (SOD pin) needs to be reduced or if the burden of polling on the MPU needs to be removed. In this case, insert a transfer wait so that the current instruction first completes execution during instruction transfer.

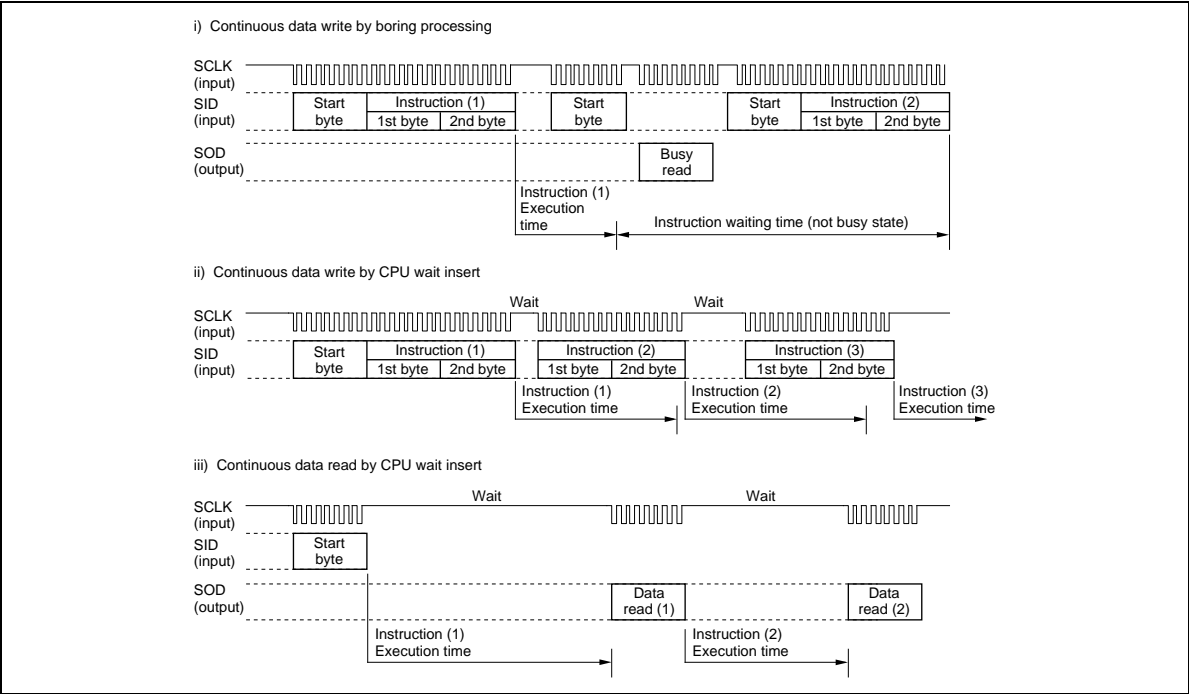


Figure 15 Procedure for Continuous Data Transfer

### Instructions

#### Outline

Only the instruction register (IR) and the data register (DR) of the HD66712 can be controlled by the MPU. Before starting internal operation of the HD66712, control information is temporarily stored in these registers to allow interfacing with various MPUs, which operate at different speeds, or various peripheral control devices. The internal operation of the HD66712 is determined by signals sent from the MPU. These signals, which include register selection (RS), read/write ( $R/\overline{W}$ ), and the data bus (DB0 to DB7), make up the HD66712 instructions (Table 12). There are four categories of instructions that:

- Designate HD66712 functions, such as display format, data length, etc.
- Set internal RAM addresses
- Perform data transfer with internal RAM
- Perform miscellaneous functions

Normally, instructions that perform data transfer with internal RAM are used the most. However, auto-incrementation by 1 (or auto-decrementation by 1) of internal HD66712 RAM addresses after each data write can lighten the program load of the MPU. Since the display shift instruction (Table 10) can perform concurrently with display data write, the user can minimize system development time with maximum programming efficiency.

When an instruction is being executed for internal operation, no instruction other than the busy flag/address read instruction can be executed.

Because the busy flag is set to 1 while an instruction is being executed, check it to make sure it is 0 before sending another instruction from the MPU.

Note: Be sure the HD66712 is not in the busy state ( $BF = 1$ ) before sending an instruction from the MPU to the HD66712. If an instruction is sent without checking the busy flag, the time between the first instruction and next instruction will take much longer than the instruction time itself. Refer to Table 12 for the list of each instruction execution time.

## **Instruction Description**

### **Clear Display**

Clear display writes space code (20)H (character pattern for character code (20)H must be a blank pattern) into all DDRAM addresses. It then sets DDRAM address 0 into the address counter, and returns the display to its original status if it was shifted. In other words, the display disappears and the cursor or blinking goes to the left edge of the display (in the first line if 2 lines are displayed). It also sets I/D to 1 (increment mode) in entry mode. S of entry mode does not change.

### **Return Home**

Return home sets DDRAM address 0 into the address counter, and returns the display to its original status if it was shifted. The DDRAM contents do not change.

The cursor or blinking goes to the left edge of the display (in the first line if 2 lines are displayed). In addition, flicker may occur in a moment at the time of this instruction issue.

### **Entry Mode Set**

I/D: Increments (I/D = 1) or decrements (I/D = 0) the DDRAM address by 1 when a character code is written into or read from DDRAM.

The cursor or blinking moves to the right when incremented by 1 and to the left when decremented by 1. The same applies to writing and reading of CGRAM and SEGRAM.

S: Shifts the entire display either to the right (I/D = 0) or to the left (I/D = 1) when S is 1 during DDRAM write. The display does not shift if S is 0.

If S is 1, it will seem as if the cursor does not move but the display does. The display does not shift when reading from DDRAM. Also, writing into or reading out from CGRAM and SEGRAM does not shift the display. In a low power mode (LP = 1), do not set S = 1 because the whole display does not normally shift.

### **Display On/Off Control**

When extension register enable bit (RE) is 0, bits D, C, and B are accessed.

**D:** The display is on when D is 1 and off when D is 0. When off, the display data remains in DDRAM, but can be displayed instantly by setting D to 1.

**C:** The cursor is displayed when C is 1 and not displayed when C is 0. Even if the cursor disappears, the function of I/D or other specifications will not change during display data write. The cursor is displayed using 5 dots in the 8th line for 5 × 8 dot character font.

## HD66712U

**B:** The character indicated by the cursor blinks when B is 1. The blinking is displayed as switching between all blank dots and displayed characters at a speed of 370-ms intervals when  $f_{cp}$  or  $f_{osc}$  is 270 kHz. The cursor and blinking can be set to display simultaneously. (The blinking frequency changes according to  $f_{osc}$  or the reciprocal of  $f_{cp}$ . For example, when  $f_{cp}$  is 300 kHz,  $370 \times 270/300 = 333$  ms.)

### Extended Function Set

When the extended register enable bit (RE) is 1, FW, B/W, and NW bit shown below are accessed. Once these registers are accessed, the set values are held even if the RE bit is set to zero.

**FW:** When FW is 1, each displayed character is controlled with a 6-dot width. The user font in CGRAM is displayed with a 6-bit character width from bits 5 to 0. As for fonts stored in CGROM, no display area is assigned to the left most bit, and the font is displayed with a 5-bit character width. If the FW bit is changed, data in DDRAM and CGRAM SEGRAM is destroyed. Therefore, set FW before data is written to RAM. When font width is set to 6 dots, the frame frequency decreases to 5/6 compared to 5-dot time. See "Oscillator Circuit" for details.

**B/W:** When B/W is 1, the character at the cursor position is cyclically displayed with black-white inversion. At this time, bits C and B in display on/off control register are "Don't care." When  $f_{cp}$  or  $f_{osc}$  is 270 kHz, display is changed by switching every 370 ms.

**NW:** When NW is 1, 4-line display is performed. At this time, bit N in the function set register is "Don't care."

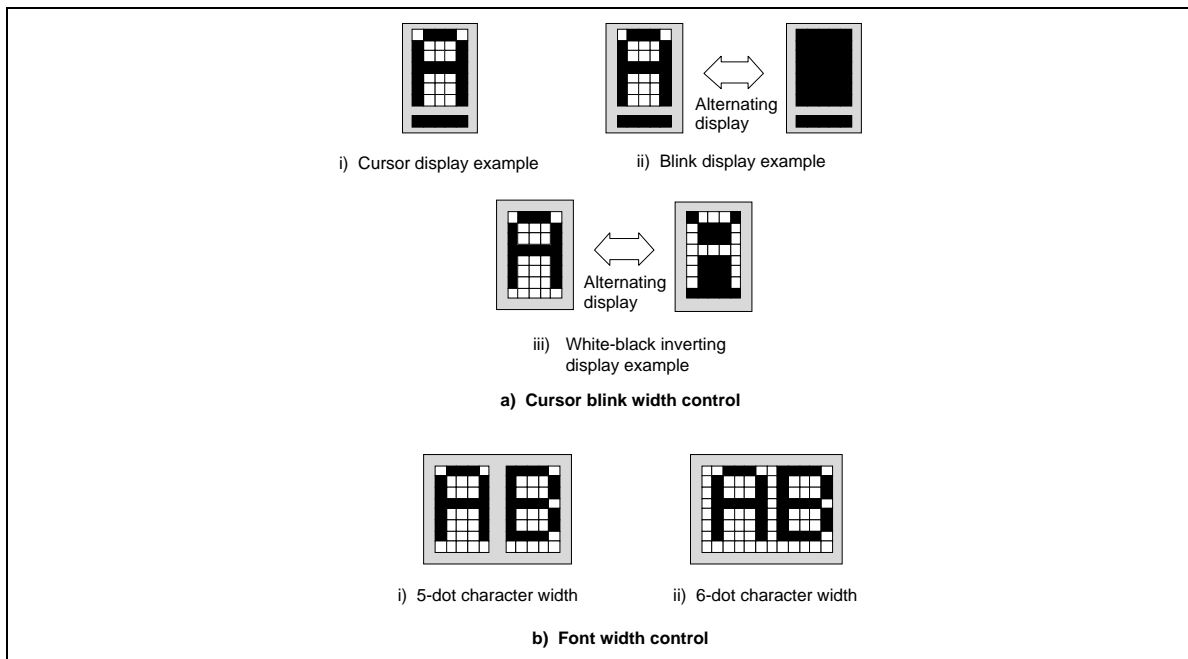


Figure 16 Example of Display Control

### **Cursor or Display Shift**

Cursor or display shift shifts the cursor position or display to the right or left without writing or reading display data (Table 10). This function is used to correct or search the display. In a 2-line display, the cursor moves to the second line when it passes the 40th digit of the first line. In a 4-line display, the cursor moves to the second line when it passes the 20th character of the line. Note that, all line displays will shift at the same time. When the displayed data is shifted repeatedly each line moves only horizontally. The second line display does not shift into the first line position. When this instruction is executed, extended register enable bit (RE) is reset.

The address counter (AC) contents will not change if the only action performed is a display shift. In low power mode (LP = 1), whole-display shift cannot be normally performed.

### **Scroll Enable**

When extended register enable bit (RE) is 1, scroll enable bits can be set.

This HSE register specifies scrolled line with the scroll quantity register. This register consists of 4 bits for each display line, so a specified line can be shifted by dot unit. When the bit 0 of HSE is 1 in four line mode (NW = 1), the first line can be shifted, and the bit 1 is specified to shift the second line, the bit 2 is specified for the third line, and bit 3 is specified for the fourth line. When it shifts the first line in two line mode (N = 1, NW = 0), both the bit 0 and bit 1 should be set to 1. The bit 2 and bit 3 is specified for the second line.

In 1 line mode (N = 0, NW = 0), the bit 0 and bit 1 should be specified.

### **Function Set**

Only when the extended register enable bit (RE) is 1, the BE and the LP bits shown below can be accessed. Bits DL and N can be accessed regardless of RE.

**DL:** Sets the interface data length. Data is sent or received in 8-bit lengths (DB7 to DB0) when DL is 1, and in 4-bit lengths (DB7 to DB4) when DL is 0. When 4-bit length is selected, data must be sent or received twice.

**N:** When bit NW in the extended function set is 0, a 1- or a 2-line display is set. When N is 0, 1-line display is selected; when N is 1, 2-line display is selected. When NW is 1, a 4-line display is set. At this time, N is "Don't care."

Note: After changing the N or NW or LP bit, please issue the Return Home or Clear Display instruction to cancel to shift display.

---

## HD66712U

---

**RE:** When bit RE is 1, bit BE in the extended function set register, the SEGRAM address set register, and the function set register can be accessed. When bit RE is 0, the registers described above cannot be accessed, and the data in these registers is held.

To maintain compatibility with the HD44780, the RE bit should be fixed to 0.

**Table 10 Shift Function**

S/C	R/L	
0	0	Shifts the cursor position to the left. (AC is decremented by one.)
0	1	Shifts the cursor position to the right. (AC is incremented by one.)
1	0	Shifts the entire display to the left. The cursor follows the display shift.
1	1	Shifts the entire display to the right. The cursor follows the display shift.

**BE:** When the RE bit is 1, this bit can be rewritten. When this bit is 1, the user font in CGRAM and the segment in SEGRAM can be blinked according to the upper two bits of CGRAM and SEGRAM.

**LP:** When bit RE is 1, this bit can be rewritten. When LP is set to 1 and the EXT pin is low (without an extended driver), the HD66712 operates in low power mode. In 1-line display mode, the HD66712 operates on a 4-division clock, and in a 2-line or a 4-line display mode, the HD66712 operates on a 2-division clock. According to these operations, instruction execution takes four times or twice as long. Note that in low power mode, display shift cannot be performed. The frame frequency is reduced to 5/6 that of normal operation. See "Oscillator Circuit" for details.

Note: Perform the DL, N, NW, and FW functions at the head of the program before executing any instructions (except for the read busy flag and address instruction). From this point, if bits N, NW, or FW are changed after other instructions are executed, RAM contents may be broken.

### Set CGRAM Address

A CGRAM address can be set while the RE bit is cleared to 0.

Set CGRAM address into the address counter displayed by binary AAAAAA. After this address set, data is written to or read from the MPU for CGRAM.

### Set SEGRAM Address

Only when the extended register enable (RE) bit is 1, HS2 to HS0 and the SEGRAM address can be set.

The SEGRAM address in the binary form AAAA is set to the address counter. After this address set, SEGRAM can be written to or read from by the MPU.

### **Set DDRAM Address**

A DDRAM address can be set while the RE bit is cleared to 0. Set DDRAM address sets the DDRAM address binary AAAAAAA into the address counter.

After this address set, data is written to or read from the MPU for DDRAM.

However, when N and NW is 0 (1-line display), AAAAAAA can be (00)H to (4F)H. When N is 1 and NW is 0 (2-line display), AAAAAAA is (00)H to (27)H for the first line, and (40)H to (67)H for the second line. When NW is 1 (4-line display), AAAAAAA is (00)H to (13)H for the first line, (20)H to (33)H for the second line, (40)H to (53)H for the third line, and (60)H to (73)H for the fourth line.

### **Set Scroll Quantity**

When extended register enable bit (RE) is 1, HDS5 to HDS0 can be set.

HDS5 to HDS0 specifies horizontal scroll quantity to the left of the display in dot units. The HD66712 uses the unused DDRAM area to execute a desired horizontal smooth scroll from 1 to 48 dots.

Note: When performing a horizontal scroll as described above by connecting an extended driver, the maximum number of characters per line decreases by the quantity set by the above horizontal scroll. For example, when the maximum 24-dot scroll quantity (4 characters) is used with 6-dot font width and 4-line display, the maximum numbers of characters is  $20 - 4 = 16$ . Notice that in low power mode (LP = 1), display shift and scroll cannot be performed.

### **Read Busy Flag and Address**

Read busy flag and address reads the busy flag (BF) indicating that the system is now internally operating on a previously received instruction. If BF is 1, the internal operation is in progress. The next instruction will not be accepted until BF is reset to 0. Check the BF status before the next write operation. At the same time, the value of the address counter in binary AAAAAAA is read out. This address counter is used by both CG, DD, and SEGRAM addresses, and its value is determined by the previous instruction. The address contents are the same as for CGRAM, DDRAM, and SEGRAM address set instructions.

### **Write Data to CG, DD, or SEGRAM**

This instruction writes 8-bit binary data DDDDDDDD to CG, DD or SEGRAM. CG, DD or SEGRAM is selected by the previous specification of the address set instruction (CGRAM address set / DDRAM address set / SEGRAM address set). After a write, the address is automatically incremented or decremented by 1 according to the entry mode. The entry mode also determines the display shift direction.

---

## HD66712U

---

### Read Data from CG, DD, or SEG RAM

This instruction reads 8-bit binary data DDDDDDDD from CG, DD, or SEGRAM. CG, DD or SEGRAM is selected by the previous specification of the address set instruction. If no address is specified, the first data read will be invalid. When executing serial read instructions, the next address is normally read from the next address. An address set instruction need not be executed just before this read instruction when shifting the cursor by a cursor shift instruction (when reading from DDRAM). A cursor shift instruction is the same as a set DDRAM address instruction.

After a read, the entry mode automatically increases or decreases the address by 1. However, a display shift is not executed regardless of the entry mode.

Note: The address counter (AC) is automatically incremented or decremented after write instructions to CG, DD or SEGRAM. The RAM data selected by the AC cannot be read out at this time even if read instructions are executed. Therefore, to read data correctly, execute either an address set instruction or a cursor shift instruction (only with DDRAM), or alternatively, execute a preliminary read instruction to ensure the address is correctly set up before accessing the data.

**Table 11 HS5 to HS0 Settings**

HDS5	HDS4	HDS3	HDS2	HDS1	HDS0	Description
0	0	0	0	0	0	No shift
0	0	0	0	0	1	Shift the display position to the left by one dot.
0	0	0	0	1	0	Shift the display position to the left by two dots.
0	0	0	0	1	1	Shift the display position to the left by three dots.
			.	.	.	
1	0	1	1	1	1	Shift the display position to the left by forty-seven dots.
1	1	*	*	*	*	Shift the display position to the left by forty-eight dots.

**Table 12 Instructions**

Instruction	RE	Code										Description	Execution Time (max) (when $f_{cp}$ or $f_{osc}$ is 270 kHz)	
	Bit	RS	R/W	DB7	DB6	DB5	DB4	DB3	DB2	DB1	DB0			
Clear display	0/1	0	0	0	0	0	0	0	0	0	0	1	Clears entire display and sets DDRAM address 0 in address counter.	1.52 ms
Return home	0/1	0	0	0	0	0	0	0	0	0	1	—	Sets DDRAM address 0 IN address counter. Also returns display from being shifted to original position. DDRAM contents remain unchanged.	1.52 ms
Entry mode set	0/1	0	0	0	0	0	0	0	0	1	I/D	S	Sets cursor move direction and specifies display shift. These operations are performed during data write and read.	37 $\mu$ s
Display on/off control	0	0	0	0	0	0	0	0	1	D	C	B	Sets entire display (D) on/off, cursor on/off (C), and blinking of cursor position character (B).	37 $\mu$ s
Extension function set	1	0	0	0	0	0	0	0	1	FW	B/W	NW	Sets a font width, a black-white inverting cursor (B/W), and a 4-line display (NW).	37 $\mu$ s
Cursor or display shift	0	0	0	0	0	0	0	1	S/C	R/L	—	—	Moves cursor and shifts display without changing DDRAM contents.	37 $\mu$ s
Scroll enable	1	0	0	0	0	0	0	1	HSE	HSE	HSE	HSE	Specifies which display lines to undergo horizontal smooth scroll.	37 $\mu$ s
Function set	0	0	0	0	0	0	1	DL	N	RE	—	—	Sets interface data length(DL), number of display lines (L), and extension register write enable (RE).	37 $\mu$ s
	1	0	0	0	0	0	1	DL	N	RE	BE	LP	Sets CGRAM/SEGRAM blinking enable (BE), and power-down mode (LP). LP is available when the EXT pin is low.	37 $\mu$ s
Set CGRAM address	0	0	0	0	0	1	ACG	ACG	ACG	ACG	ACG	Ay	Sets CGRAM address. CGRAM data is sent and received after this setting.	37 $\mu$ s
Set SEGRAM address set	1	0	0	0	0	1	*	*	ASEG	ASEG	ASEG	ASEG	Sets SEGRAM address. SEGRAM data is sent and received after this setting.	37 $\mu$ s

# HD66712U

**Table 12 Instructions (cont)**

Instruction	RE Bit	Code										Description	Execution Time (max) (when $f_{cp}$ or $f_{osc}$ is 270 kHz)	
		RS	R/W	DB7	DB6	DB5	DB4	DB3	DB2	DB1	DB0			
Set DDRAM address	0	0	0	1	ADD	ADD	ADD	ADD	ADD	ADD	ADD	Sets DDRAM address. DDRAM data is sent and received after this setting.	37 $\mu$ s	
Set scroll quantity	1	0	0	1	*	HDS	HDS	HDS	HDS	HDS	HDS	Sets horizontal dot scroll quantity.	37 $\mu$ s	
Read busy flag & address	0/1	0	1	BF	AC	AC	AC	AC	AC	AC	AC	Reads busy flag (BF) indicating internal operation is being performed and reads address counter contents.	0 $\mu$ s	
Write data to RAM	0/1	1	0									Write data	Writes data into DDRAM, CGRAM, or SEGRAM.	7 $\mu$ s $t_{ADD} = 5.5 \mu\text{s}^*$
Read data from RAM	0/1	1	1									Read data	Reads data from DDRAM, CGRAM, or SEGRAM.	37 $\mu$ s $t_{ADD} = 5.5 \mu\text{s}^*$
I/D = 1: Increment I/D = 0: Decrement S = 1: Accompanies display shift D = 1: Display on C = 1: Cursor on B = 1: Blink on FW = 1: 6-dot font width B/W = 1: Black-white inverting cursor on NW = 1: Four lines NW = 0: One or two lines S/C = 1: Display shift S/C = 0: Cursor move R/L = 1: Shift to the right R/L = 0: Shift to the left DL = 1: 8 bits, DL = 0: 4 bits N = 1: 2 lines, N = 0: 1 line RE = 1: Extension register access enable BE = 1: CGRAM/SEGRAM blinking enable LP = 1: Low-power mode BF = 1: Internally operating BF = 0: Instructions acceptable												DDRAM: Display data RAM ADD: DDRAM address (corresponds to cursor address) CGRAM: Character generator RAM ACG: CGRAM address SEGRAM: Segment RAM ASEG: Segment RAM address HSE: Specifies horizontal scroll lines HDS: Horizontal dot scroll quantity AC: Address counter used for both DD, CG, and SEGRAM addresses.		

Note: 1. — indicates no effect.

- \* After execution of the CGRAM/DDRAM data write or read instruction, the RAM address counter is incremented or decremented by 1. The RAM address counter is updated after the busy flag turns off. In Figure 17,  $t_{ADD}$  is the time elapsed after the busy flag turns off until the address counter is updated.
- 2. Extension time changes as frequency changes. For example, when  $f$  is 300 kHz, the execution time is:  $37 \mu\text{s} \times 270/300 = 33 \mu\text{s}$ .
- 3. Execution time in a low-power mode (LP = 1 and EXT = low) becomes four times for a 1-line mode, and twice for a 2- or 4-line mode.

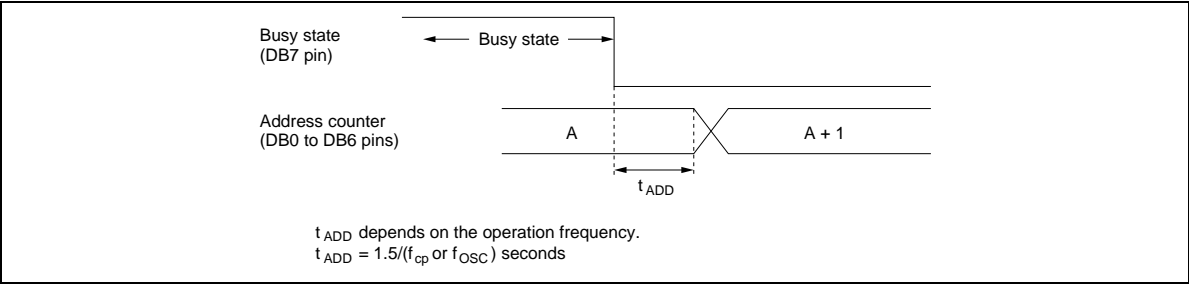


Figure 17 Address Counter Update

---

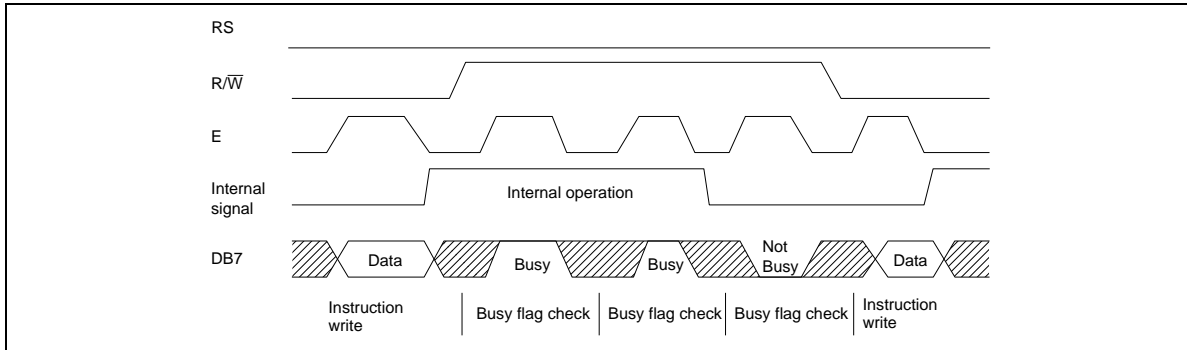
## HD66712U

---

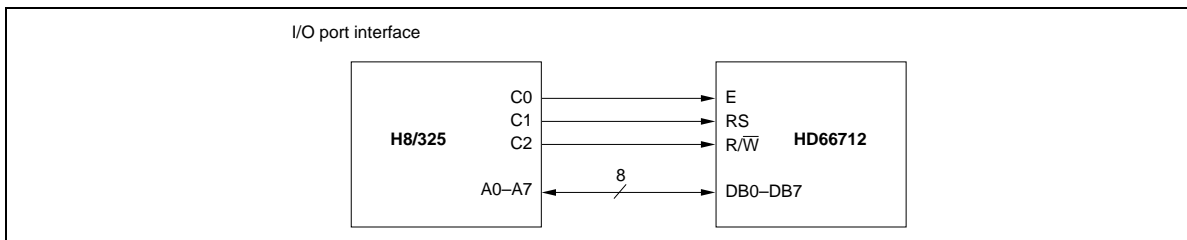
### Interfacing the HD66712

**Interface with 8-Bit MPUs:** The HD66712 can interface directly with an 8-bit MPU using the E clock, or with an 8-bit MCU through an I/O port.

When the number of I/O ports in the MCU, or the interfacing bus width, is limited, a 4-bit interface function is used.



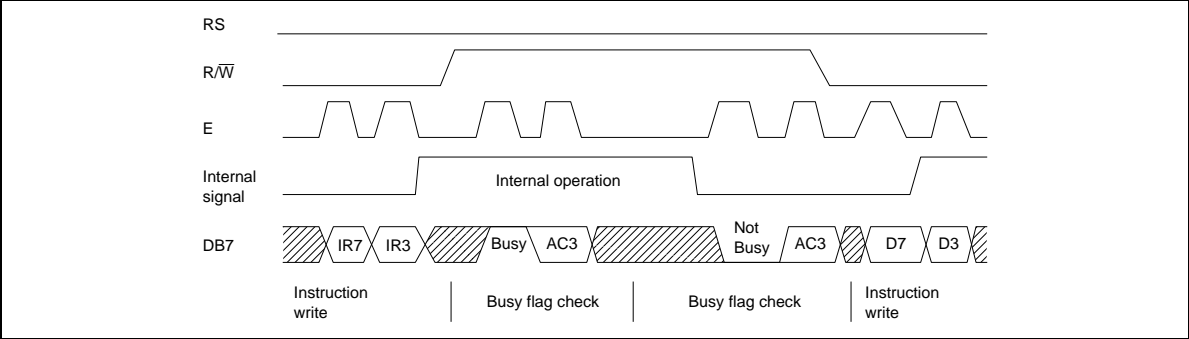
**Figure 18 Example of 8-Bit Data Transfer Timing Sequence**



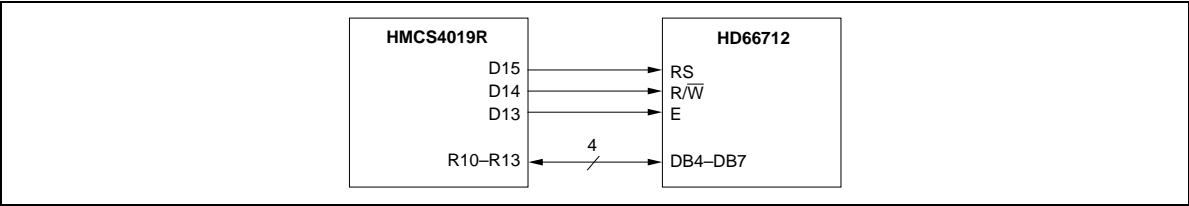
**Figure 19 8-Bit MPU Interface**

**Interface with 4-Bit MPUs:** The HD66712 can interface with a 4-bit MCU through an I/O port. 4-bit data representing high and low order bits must be transferred sequentially.

The DL bit in function-set selects 4-bit or 8-bit interface data length.

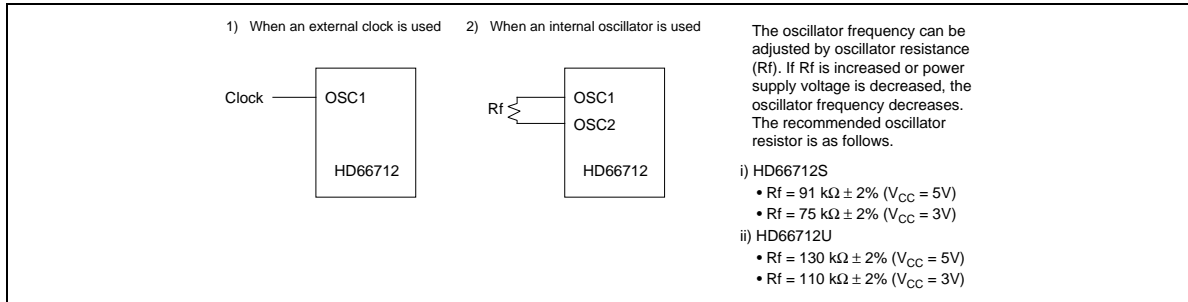


**Figure 20 Example of 4-Bit Data Transfer Timing Sequence**

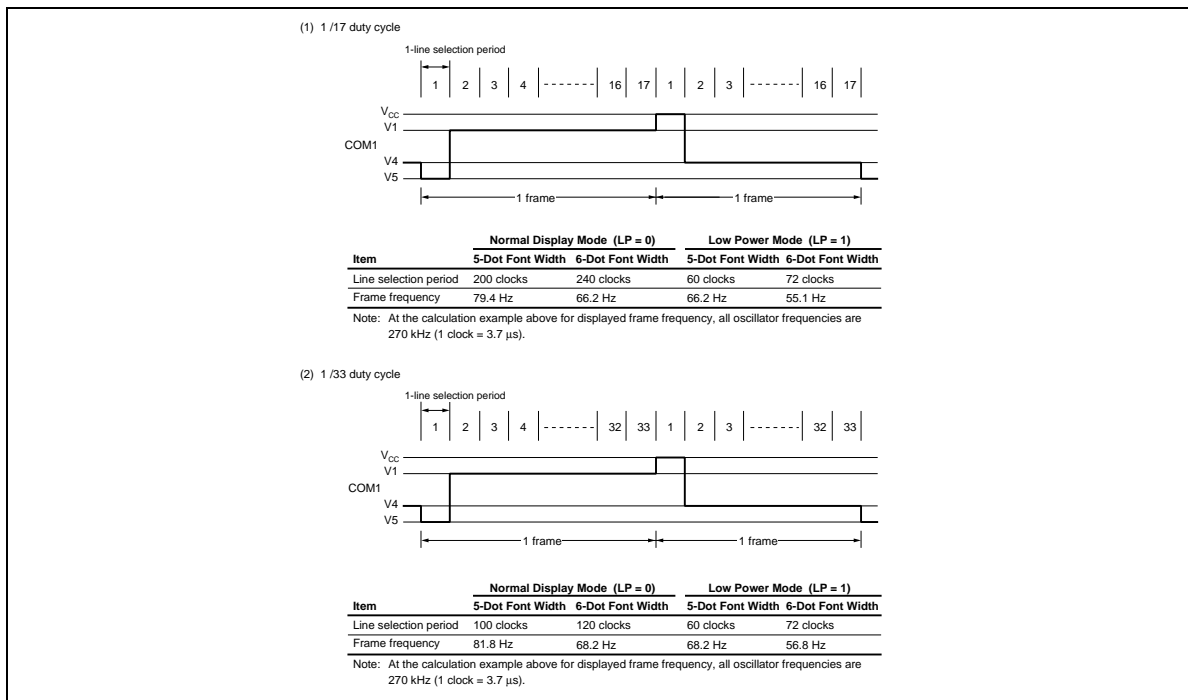


**Figure 21 4-bit MPU Interface**

## Oscillator Circuit



**Figure 22 Oscillator Circuit**

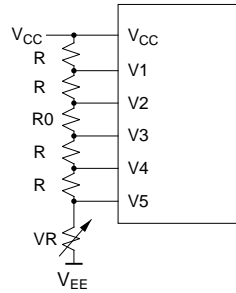


(2) 1/33 duty cycle

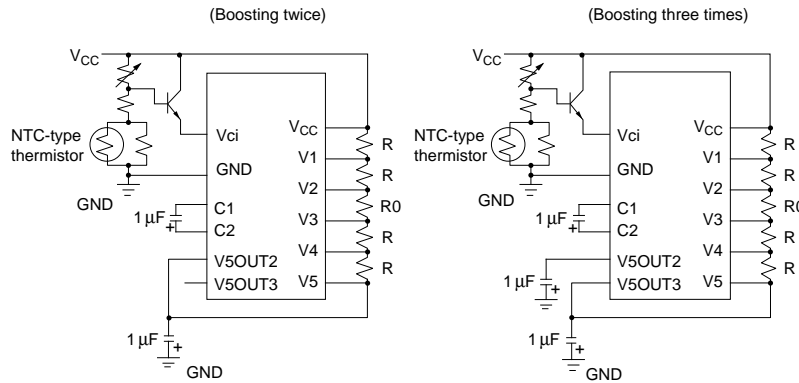
**Figure 23 Frame Frequency**

## Power Supply for Liquid Crystal Display Drive

1) When an external power supply is used



2) When an internal booster is used



- Notes:
1. Boosting output voltage should not exceed the power supply voltage (2) (13V max.) in the absolute maximum ratings. Especially, voltage of over 4.3V should not be input to the reference voltage (Vci) when boosting three times.
  2. Vci input terminal is used for reference voltage and power supply for the internal booster. Input current into the Vci pin needs three times or more of load current through the bleeder resistor for LCD. So, when it adjusts LCD driving voltage (Vlcd), input voltage should be controlled with transistor to supply LCD load current. Please notice connection (+/-) when it uses capacitors with polar.
  3. The Vci must be set below the power supply (VCC).

---

## HD66712U

---

**Table 13 Duty Factor and Power Supply for Liquid Crystal Display Drive**

Item	Data		
Number of Lines	1	2, 4	
Duty factor	1/17	1/33	
Bias	1/5	1/6.7	
Divided resistance	R	R	R
	R0	R	2.7R

Note: R changes depending on the size of liquid crystal panel. Normally, R must be 4.7 kΩ to 20 kΩ.

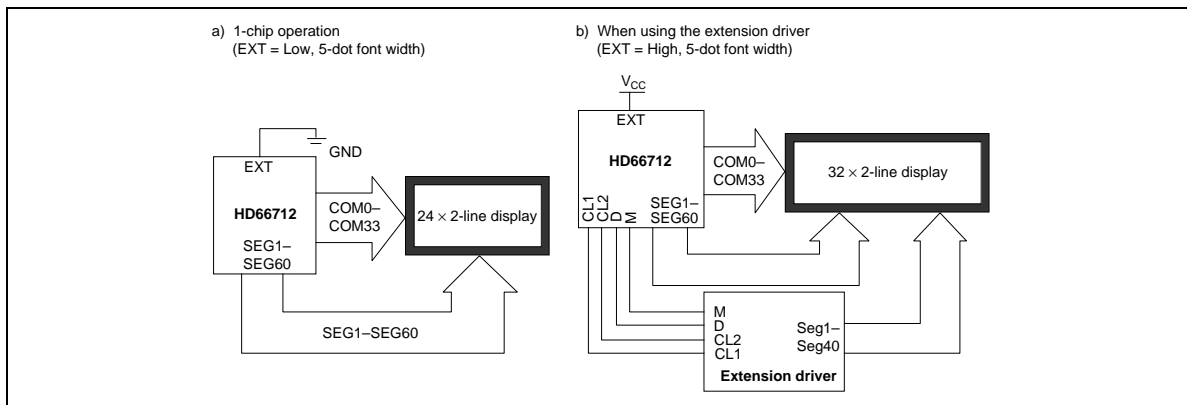
**Extension Driver LSI Interface**

By bringing the EXT pin high, extended driver interface signals (CL1, CL2, D, and M) are output.

**Table 14 Relationships between the Number of Display Lines and 40-Output Extension Driver**

Display Lines	Controller					
	HD66712		HD66710		HD44780	HD66702
	5-Dot Width	6-Dot Width	5-Dot Width	6-Dot Width	5-Dot Width	5-Dot Width
16 × 2 lines	Not required	Not required	Not required	1	1	Not required
20 × 2 lines	Not required	Not required	1	1	2	Not required
24 × 2 lines	Not required	1	1	2	2	1
40 × 2 lines	Disabled	Disabled	Disabled	Disabled	4	3
12 × 4 lines	Not required	1	1	1	Disabled	Disabled
16 × 4 lines	1	1	1	2	Disabled	Disabled
20 × 4 lines	1	2	2	3	Disabled	Disabled

Note: The number of display lines can be extended to 32 × 2 lines or 20 × 4 lines in the LCD-II/F12.  
 The number of display lines can be extended to 30 × 2 lines or 20 × 4 lines in the LCD-II/F8.



**Figure 24 HD66712 and the Extension Driver Connection**

## HD66712U

**Table 15 Display Start Address in Each Mode**

Output	Number of Lines				
	1-Line Mode		2-Line Mode		4-Line Mode
	5 Dot	6 Dot	5 Dot	6 Dot	5 Dot/6 Dot
COM1–COM8	D00±1	D00±1	D00±1	D00±1	D00±1
COM9–COM16	D0C±1	D0A±1	D0C±1	D0A±1	D20±1
COM17–COM24	—	—	D40±1	D40±1	D40±1
COM25–COM32	—	—	D4C±1	D4A±1	D60±1
COM0/COM17	S00	S00	—	—	—
COM0/COM33	—	—	S00	S00	S00

- Notes:
1. The number of display lines is determined by setting the N/NW bit. The font width is determined by the FW bit.
  2. D\*\* is the start address of display data RAM (DDRAM).
  3. S\*\* is the start address of segment RAM (SEGRAM).
  4. ±1 following D\*\* indicates increment or decrement at display shift.

Interface to Liquid Crystal Display

- Example of 5-dot font width connection

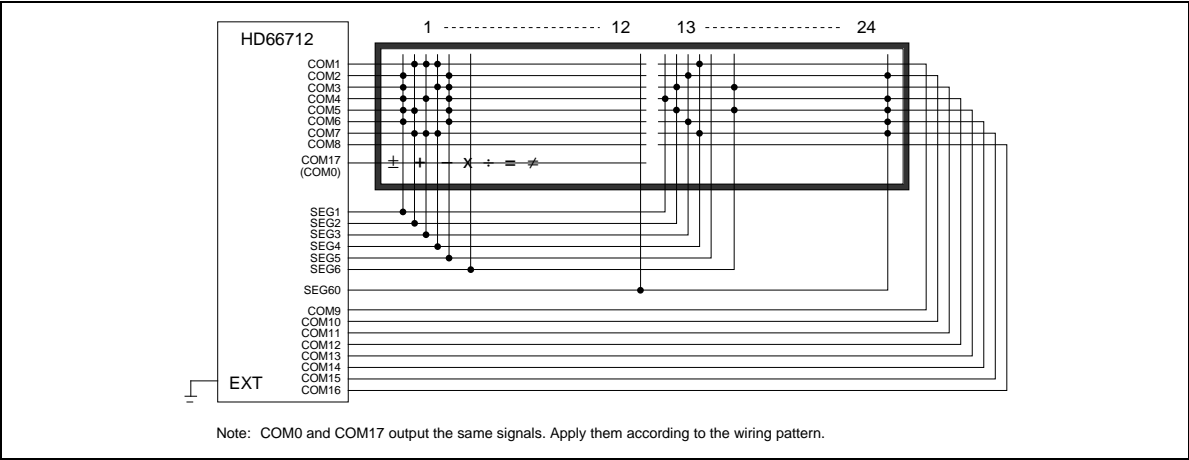


Figure 25 24 × 1-Line + 60-Segment Display (5-Dot Font, 1/17 Duty)

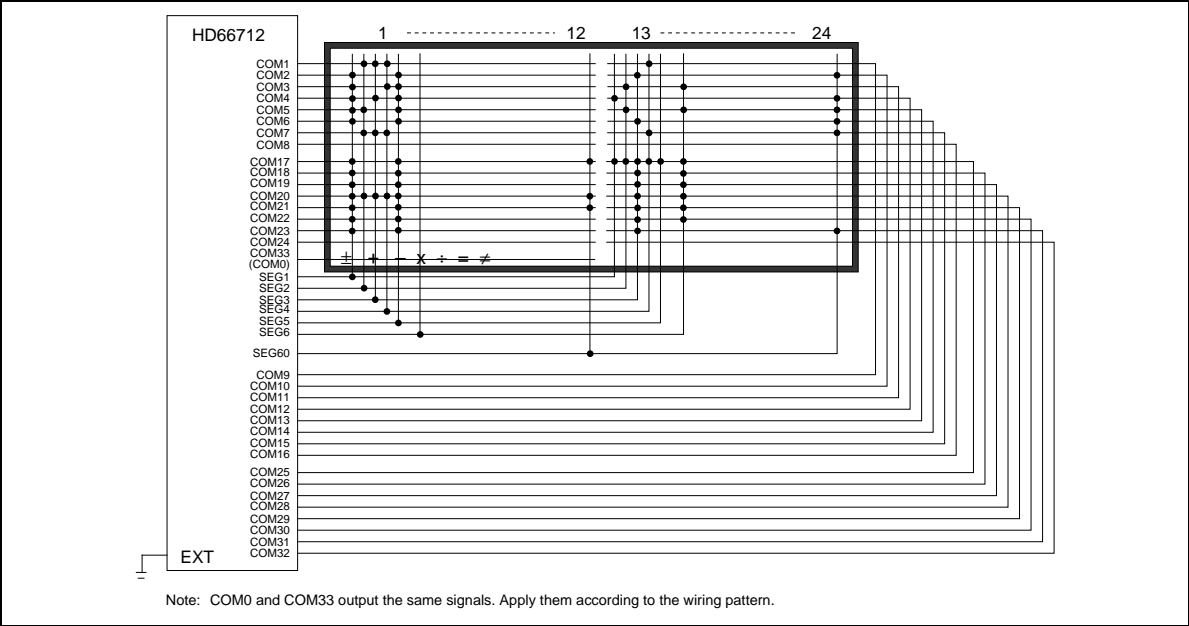


Figure 26 24 × 1-Line + 60-Segment Display (5-Dot Font, 1/33 Duty)

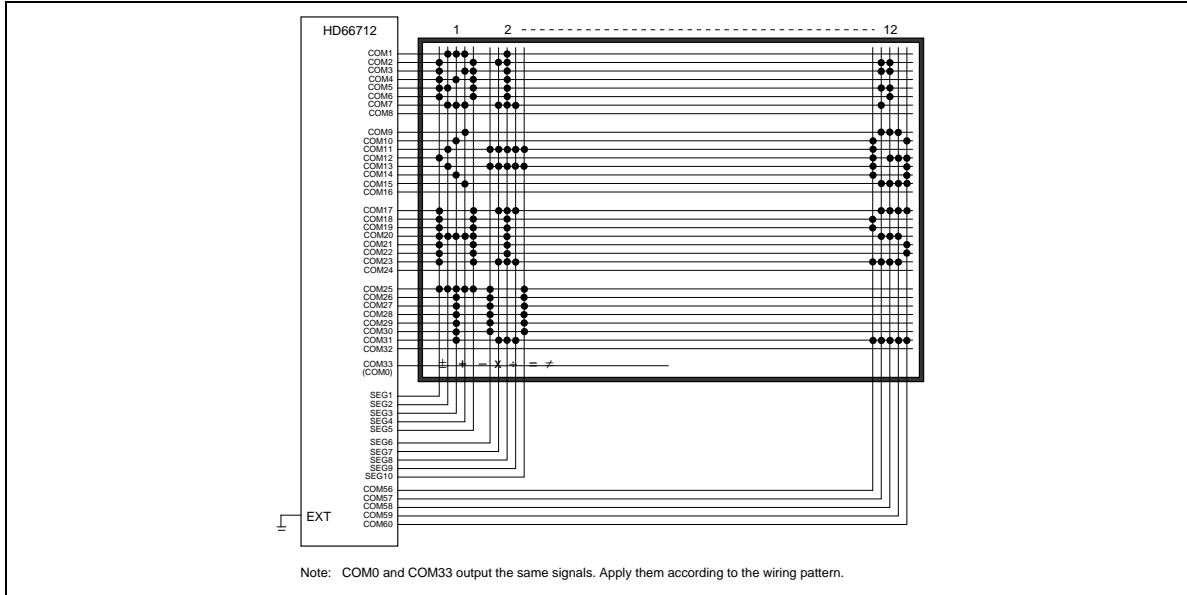


Figure 27 12 × 4-Line + 60 Segment Display (5-Dot Font, 1/33 Duty)

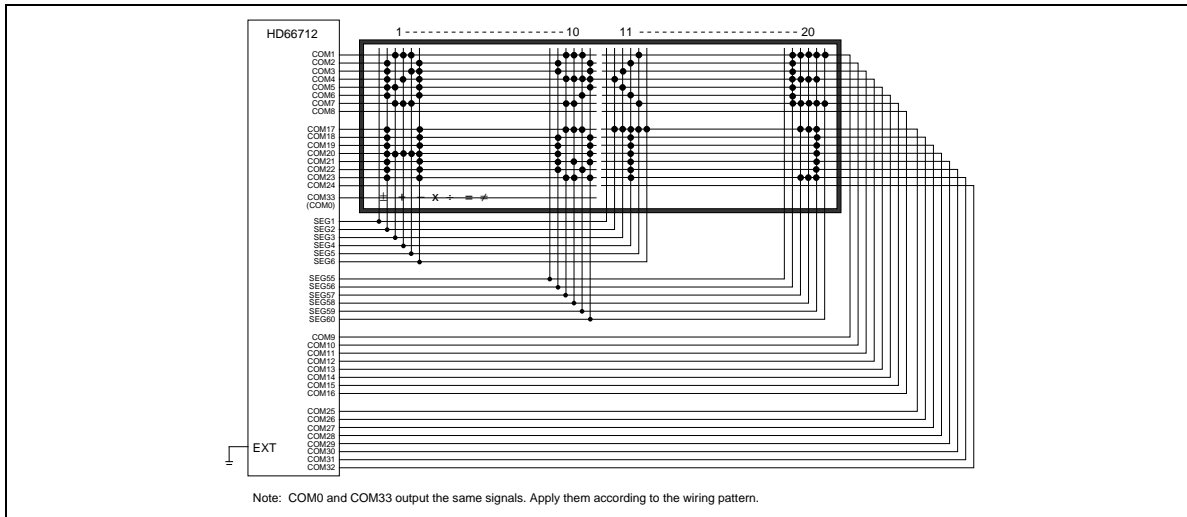


Figure 28 20 × 2-Line + 60 Segment Display (6-Dot Font, 1/33 Duty)

## **Instruction and Display Correspondence**

- 8-bit operation, 24-digit × 1-line display with internal reset  
Refer to Table 16 for an example of an 24-digit × 1-line display in 8-bit operation. The HD66712 functions must be set by the function set instruction prior to the display. Since the display data RAM can store data for 80 characters, a character unit scroll can be performed by a display shift instruction. A dot unit smooth scroll can also be performed by a horizontal scroll instruction. Since data of display RAM (DDRAM) is not changed by a display shift instruction, the display can be returned to the first set display when the return home operation is performed.
- 4-bit operation, 24-digit × 1-line display with internal reset  
The program must set all functions prior to the 4-bit operation (see Table 17.) When the power is turned on, 8-bit operation is automatically selected and the first write is performed as an 8-bit operation. Since DB0 to DB3 are not connected, a rewrite is then required. However, since one operation is completed in two accesses for 4-bit operation, a rewrite is needed to set the functions. Thus, DB4 to DB7 of the function set instruction is written twice.
- 8-bit operation, 24-digit × 2-line display with internal reset  
For a 2-line display, the cursor automatically moves from the first to the second line after the 40th digit of the first line has been written. Thus, if there are only 16 characters in the first line, the DDRAM address must be again set after the 16th character is completed. (See Table 18.)  
The display shift is performed for the first and second lines. If the shift is repeated, the display of the second line will not move to the first line. The same display will only shift within its own line for the number of times the shift is repeated.
- 8-bit operation, 12-digit × 4-line display with internal reset  
The RE bit must be set by the function set instruction and then the NW bit must be set by an extension function set instruction. In this case, 4-line display is always performed regardless of the N bit setting (see Table 19).  
In a 4-line display, the cursor automatically moves from the first to the second line after the 20th digit of the first line has been written. Thus, if there are only 8 characters in the first line, the DDRAM address must be set again after the 8th character is completed. Display shifts are performed on all lines simultaneously.

Note: When using the internal reset, the electrical characteristics in the Power Supply Conditions Using Internal Reset Circuit Table must be satisfied. If not, the HD66712 must be initialized by instructions. See the section, Initializing by Instruction.

# HD66712U

**Table 16 8-Bit Operation, 24-Digit × 1-Line Display Example with Internal Reset**

Step	Instruction										Display	Operation
No.	RS	R/W	DB7	DB6	DB5	DB4	DB3	DB2	DB1	DB0		
1	Power supply on (the HD66712 is initialized by the internal reset circuit)										<input type="text"/>	Initialized. No display.
2	Function set 0 0 0 0 1 1 0 0 * *										<input type="text"/>	Sets to 8-bit operation and selects 1-line display. Bit 2 must always be cleared.
3	Return home 0 0 0 0 0 0 0 0 1 0										<input type="text"/>	Return both display and cursor to the original position(address 0).
4	Display on/off control 0 0 0 0 0 0 1 1 1 0										<input type="text"/>	Turns on display and cursor. Entire display is in space mode because of initialization.
5	Entry mode set 0 0 0 0 0 0 0 1 1 0										<input type="text"/>	Sets mode to increment the address by one and to shift the cursor to the right at the time of write to the RAM. Display is not shifted.
6	Write data to CGRAM/DDRAM 1 0 0 1 0 0 1 0 0 0										<input type="text" value="H_"/>	Writes H. DDRAM has already been selected by initialization when the power was turned on.
7	Write data to CGRAM/DDRAM 1 0 0 1 0 0 1 0 0 1										<input type="text" value="HI_"/>	Writes I.
8											<input type="text"/>	
9	Write data to CGRAM/DDRAM 1 0 0 1 0 0 1 0 0 1										<input type="text" value="HITACHI_"/>	Writes I.
10	Entry mode set 0 0 0 0 0 0 0 1 1 1										<input type="text" value="HITACHI_"/>	Sets mode to shift display at the time of write.
11	Write data to CGRAM/DDRAM 1 0 0 0 1 0 0 0 0 0										<input type="text" value="ITACHI _"/>	Writes a space.

Table 16 8-Bit Operation, 24-Digit × 1-Line Display Example with Internal Reset (cont)

Step	Instruction										Display	Operation
No.	RS	R/W	DB7	DB6	DB5	DB4	DB3	DB2	DB1	DB0		
12	Write data to CGRAM/DDRAM										TACHI M_	Writes M.
	1	0	0	1	0	0	1	1	0	1		
13												.
												.
												.
												.
14	Write data to CGRAM/DDRAM										MICROKO_	Writes O.
	1	0	0	1	0	0	1	1	1	1		
15	Cursor or display shift										MICROKO	Shifts only the cursor position to the left.
	0	0	0	0	0	1	0	0	*	*		
16	Cursor or display shift0										MICROKO	Shifts only the cursor position to the left.
	0	0	0	0	1	0	0	*	*			
17	Write data to CGRAM/DDRAM										ICROCO	Writes C over K. The display moves to the left.
	1	0	0	1	0	0	0	0	1	1		
18	Cursor or display shift										MICROCO	Shifts the display and cursor position to the right.
	0	0	0	0	0	1	1	1	*	*		
19	Cursor or display shift										MICROCO_	Shifts the display and cursor position to the right.
	0	0	0	0	0	1	0	1	*	*		
20	Write data to CGRAM/DDRAM										ICROCOM_	Writes M.
	1	0	0	1	0	0	1	1	0	1		
21												.
												.
												.
												.
												.
22	Return home										HITACHI	Returns both display and cursor to the original position (address 0).
	0	0	0	0	0	0	0	0	1	0		

# HD66712U

**Table 17 4-Bit Operation, 24-Digit × 1-Line Display Example with Internal Reset**

Step No.	Instruction										Display	Operation
	RS	R/W	DB7	DB6	DB5	DB4	DB3	DB2	DB1	DB0		
1	Power supply on (the HD66712 is initialized by the internal reset circuit)										<input type="text"/>	Initialized. No display.
2	Function set 0 0 0 0 1 0 — — — — — — — — — — — — — —										<input type="text"/>	Sets to 4-bit operation. Clear bit 2. In this case, operation is handled as 8 bits by initialization. *1
3	Function set 0 0 0 0 1 0 — — — — 0 0 0 1 0 0 — — — —										<input type="text"/>	Sets 4-bit operation and selects 1-line display. Clear BE, LP bits. 4-bit operation starts from this step.
4	Function set 0 0 0 0 1 0 — — — — 0 0 0 0 * * — — — —										<input type="text"/>	Sets 4-bit operation and selects 1 line display. Clear bit 2 (RE).
5	Return home 0 0 0 0 0 0 — — — — 0 0 0 0 1 0 — — — —										<input type="text"/>	Returns both display and cursor to the original position (address 0).
6	Display on/off control 0 0 0 0 0 0 — — — — 0 0 1 1 1 0 — — — —										<input type="text"/>	Turns on display and cursor. Entire display is in space mode because of initialization.
7	Entry mode set 0 0 0 0 0 0 — — — — 0 0 0 1 1 0 — — — —										<input type="text"/>	Sets mode to increment the address by one and to shift the cursor to the right at the time of write to the DD/CGRAM. Display is not shifted.
8	Write data to CGRAM/DDRAM 1 0 0 1 0 0 — — — — 1 0 1 0 0 0 — — — —										<input type="text" value="H"/>	Writes H. DDRAM has already been selected by initialization.
9											<input type="text"/>	Based on 8-bit operation after this instruction

Note: The control is the same as for 8-bit operation beyond step #8.

1. When DB3 to DB0 pins are open in 4-bit mode, the RE, BE, LP bits are set to "1" at step #2. So, these bits are clear to "0" at step #3.

**Table 18 8-Bit Operation, 24-Digit × 2-Line Display Example with Internal Reset**

Step No.	RS	R/W	DB7	DB6	DB5	DB4	DB3	DB2	DB1	DB0	Display	Operation
1												Initialized. No display.
2	0	0	0	0	1	1	1	0	*	*		Sets to 8-bit operation and selects 2-line display. Clear bit 2.
3	0	0	0	0	0	0	1	1	1	0		Turns on display and cursor. All display is in space mode because of initialization.
4	0	0	0	0	0	0	0	1	1	0		Sets mode to increment the address by one and to shift the cursor to the right at the time of write to the RAM. Display is not shifted.
5	1	0	0	1	0	0	1	0	0	0		Writes "H." DDRAM has already been selected by initialization at power-on.
6					.	.	.	.	.	.		
7	1	0	0	1	0	0	1	0	0	1		Writes I.
8	0	0	1	1	0	0	0	0	0	0		Sets DDRAM address so that the cursor is positioned at the head of the second line.

# HD66712U

**Table 18 8-Bit Operation, 24-Digit × 2-Line Display Example with Internal Reset (cont)**

Step No.	RS	R/W	DB7	DB6	DB5	DB4	DB3	DB2	DB1	DB0	Display	Operation
9	1	0	0	1	0	0	1	1	0	1	HITACHI M_	Writes a space.
10											.	.
											.	.
											.	.
											.	.
11	1	0	0	1	0	0	1	1	1	1	HITACHI MICROCO_	Writes O.
12	0	0	0	0	0	0	0	1	1	1	HITACHI MICROCO_	Sets mode to shift display at the time of write.
13	1	0	0	1	0	0	1	1	0	1	ITACHI ICROCOM_	Writes M.
14											.	.
											.	.
											.	.
											.	.
17	0	0	0	0	0	0	0	0	1	0	HITACHI MICROCOM	Returns both display and cursor to the original position (address 0).

**Table 19 8-Bit Operation, 12-Digit × 4-Line Display Example with Internal Reset**

Step No.	Instruction										Display	Operation
	RS	R/W	DB7	DB6	DB5	DB4	DB3	DB2	DB1	DB0		
1	Power supply on (the HD66712 is initialized by the internal reset circuit)											Initialized. No display.
2	0	0	0	0	1	1	1	1	*	*		Sets 8-bit operation and enables write to the extension register.
3	0	0	0	0	0	0	1	0	0	1		Sets 4-line operation.
4	Function set Inhibit write to extension register											Inhibits write to extension register. Invalidates selection of 1-line/2-line by bit 3.
5	Display on/off control											Turns on display and cursor. Entire display is cleared because of initialization.
6	Entry mode set											Sets mode to increment the address by one and to shift the cursor to the right when writing to RAM. Display is not shifted.
7	Write data to CGRAM/DDRAM											Writes H. DDRAM has already been selected by initialization.
8					.							.
					.							.
					.							.
					.							.
					.							.

# HD66712U

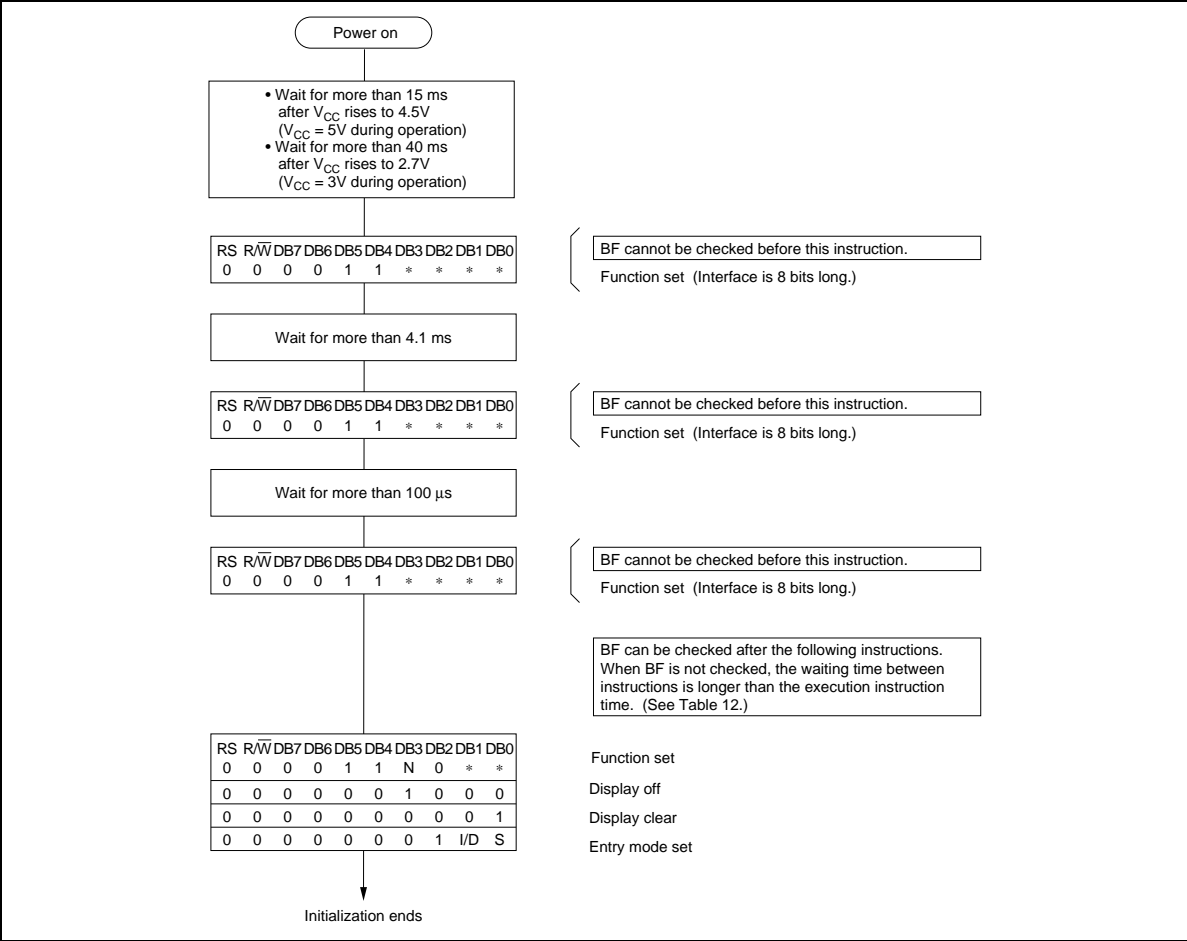
**Table 19 8-Bit Operation, 12-Digit × 4-Line Display Example with Internal Reset (cont)**

Step		Instruction									Display	Operation	
No.	RS	R/W	DB7	DB6	DB5	DB4	DB3	DB2	DB1	DB0			
9	Write data to CGRAM/DDRAM	1	0	0	1	0	0	1	0	0	1	<div style="border: 1px solid black; padding: 2px;">HITACHI_</div> <div style="border: 1px solid black; padding: 2px;"> </div> <div style="border: 1px solid black; padding: 2px;"> </div> <div style="border: 1px solid black; padding: 2px;"> </div>	Writes I.
10	Set DDRAM address	0	0	1	0	1	0	0	0	0	0	<div style="border: 1px solid black; padding: 2px;">HITACHI</div> <div style="border: 1px solid black; padding: 2px;">_</div> <div style="border: 1px solid black; padding: 2px;"> </div> <div style="border: 1px solid black; padding: 2px;"> </div>	Sets DDRAM address to (20)H so that the cursor is positioned at the beginning of the second line.
11	Write data to CGRAM	1	0	0	0	1	1	0	0	0	0	<div style="border: 1px solid black; padding: 2px;">HITACHI</div> <div style="border: 1px solid black; padding: 2px;">0_</div> <div style="border: 1px solid black; padding: 2px;"> </div> <div style="border: 1px solid black; padding: 2px;"> </div>	Writes 0.

**Initializing by Instruction**

If the power supply conditions for correctly operating the internal reset circuit are not met, initialization by instructions becomes necessary.

- Initializing when a length of interface is 8-bit system. (See Figure 29.)
- Initializing when a length of interface is 4-bit system. (See Figure 30.)



**Figure 29 Initializing Flow of 8-Bit Interface**

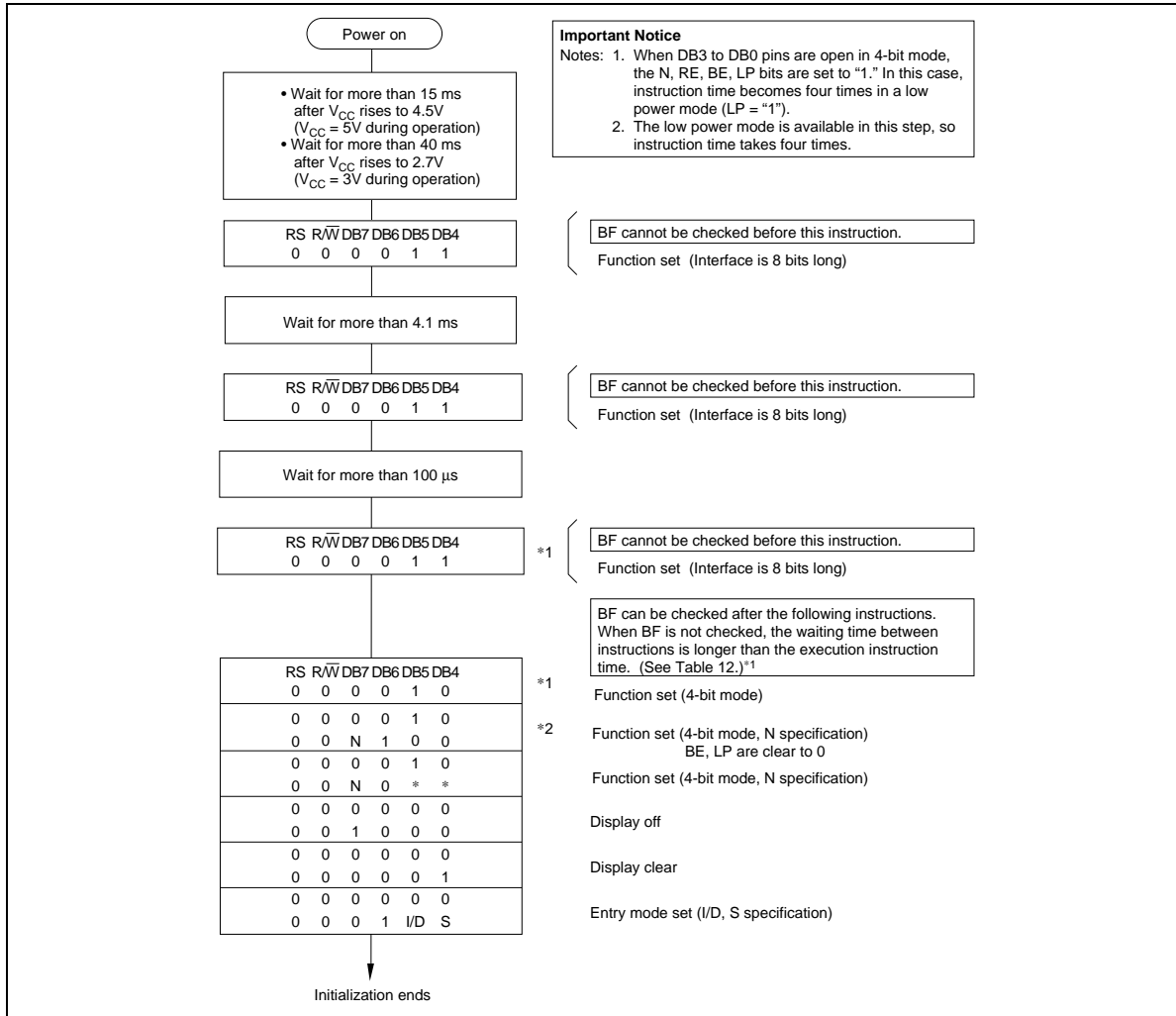


Figure 30 Initializing Flow of 4-Bit Interface

### Horizontal Dot Scroll

Dot unit scrolls are performed by setting the horizontal dot scroll quantity register (HDS) when the extension register is enabled (RE = "1"). And the shifted line can be selected with the scroll enable register (HDE). So, it can control dot unit shifts by each display line.

To scroll smoothly, HD66712 supports 6 dots-font width mode (FW = 1). The below figures are examples of scroll display.

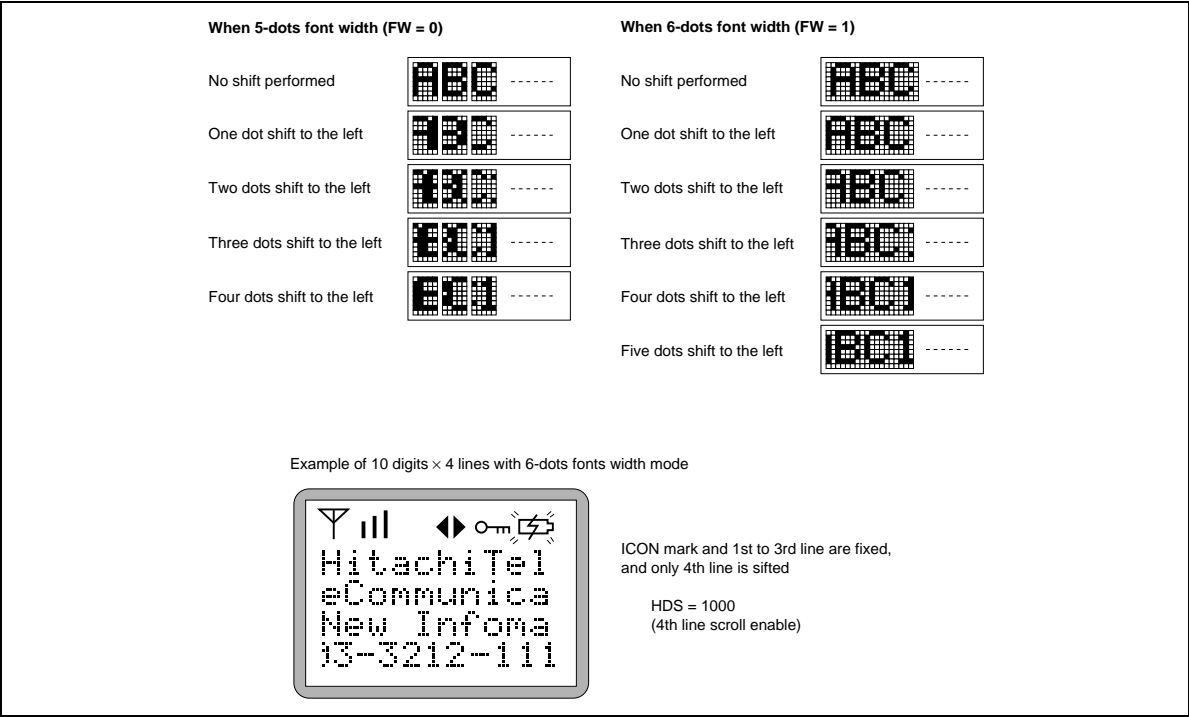


Figure 31 Example of Dot Scroll Display

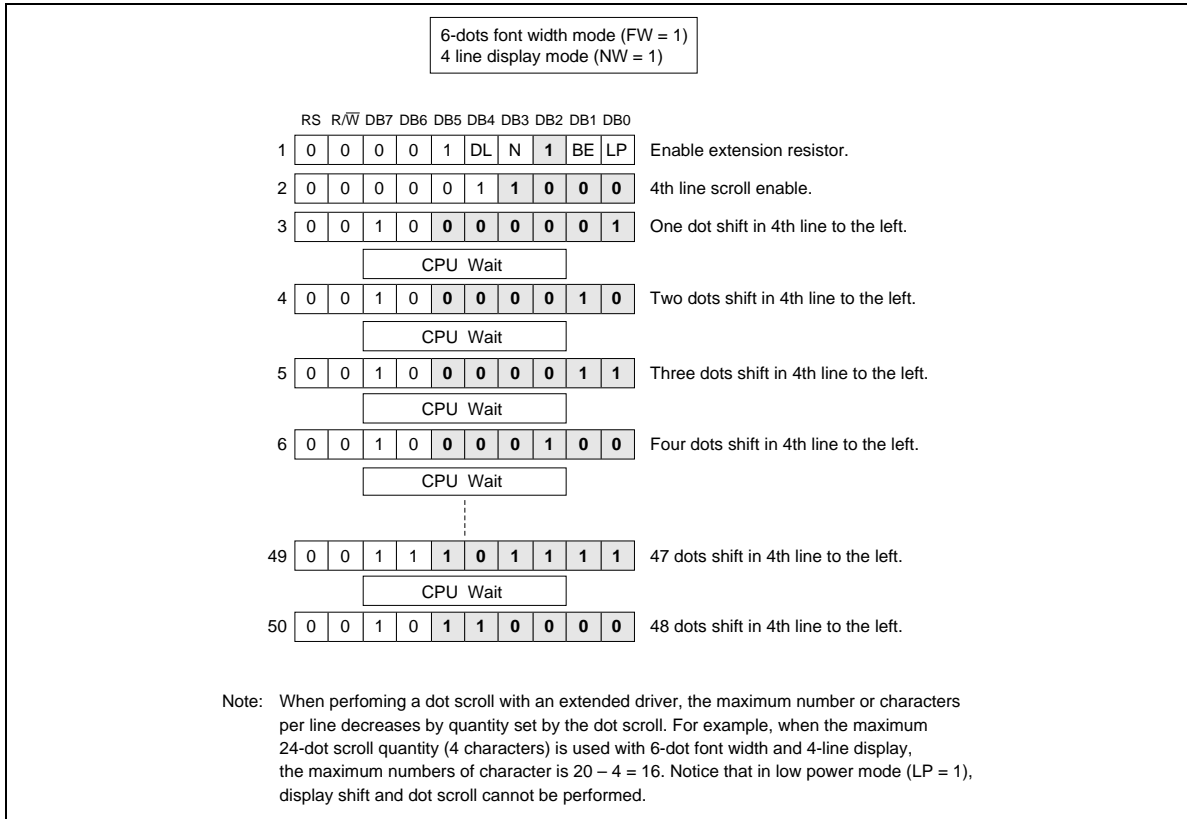
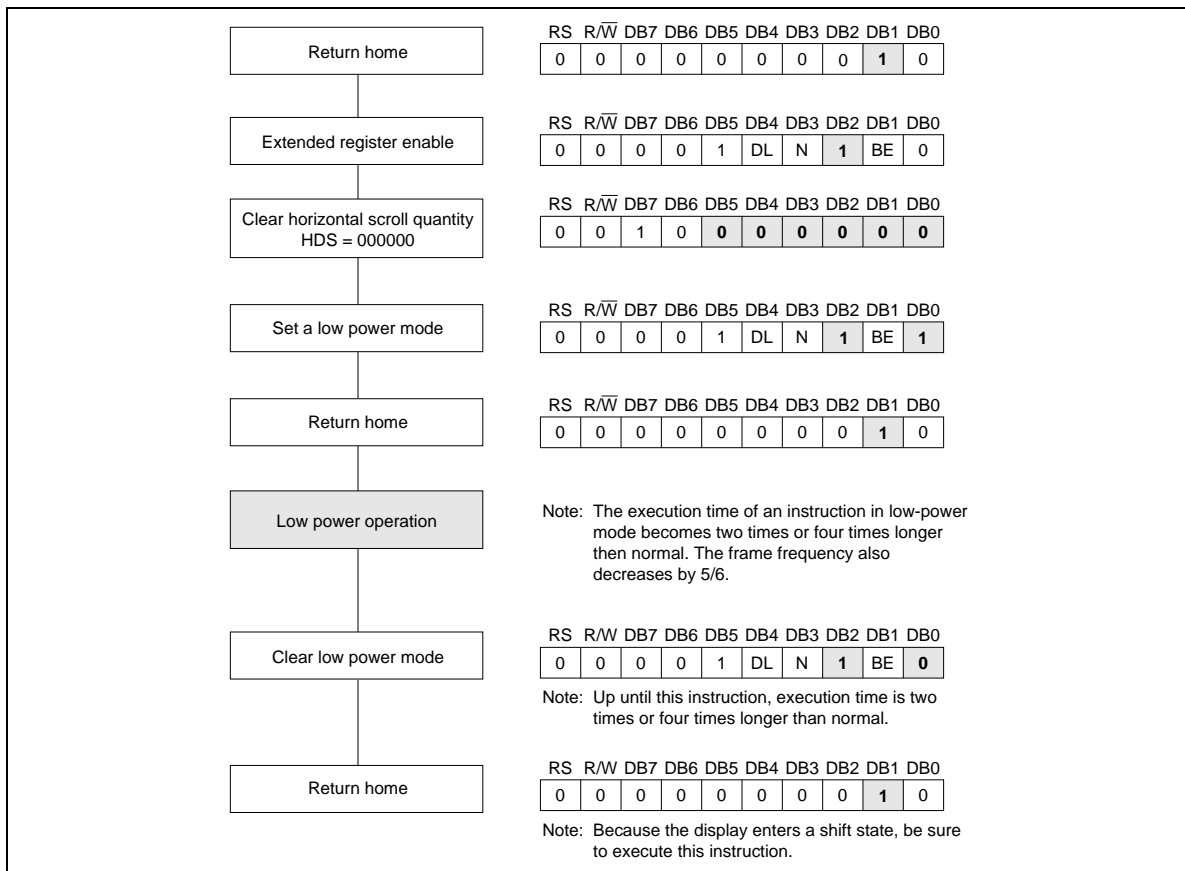


Figure 32 Method of Smooth Scroll Display

**Low Power Mode**

When the extension driver is not used (EXT = Low) with extension register enabled (RE = 1), the HD66712 enters low power mode by setting the low-power mode bit (LP) to 1. During low-power mode, as the internal operation clock is divided by 2 (2-line/4-line display mode) or by 4 (1-line display mode), the execution time of each instruction becomes two times or four times longer than normal. In addition, as the frame frequency decreases to 5/6, display quality might be affected.

In addition, since the display is not shifted in low power mode, display shift must be cleared with the return home instruction before setting low power mode. The amount of horizontal scroll must also be cleared (HDS = 000000). Moreover, because the display enters a shift state after clearing low-power mode, the home return instruction must be used to clear display shift at that time.



**Figure 33 Usage of Low Power Mode**

---

## HD66712U

---

### Absolute Maximum Ratings\*

Item	Symbol	Unit	Value	Notes
Power supply voltage (1)	$V_{CC}$	V	-0.3 to +7.0	1
Power supply voltage (2)	$V_{CC}-V_5$	V	-0.3 to +13.0	1, 2
Input voltage	$V_t$	V	-0.3 to $V_{CC} + 0.3$	1
Operating temperature	$T_{opr}$	°C	-20 to +75	
Storage temperature	$T_{stg}$	°C	-55 to +125	4

Note: \* If the LSI is used above these absolute maximum ratings, it may become permanently damaged. Using the LSI within the following electrical characteristic limits is strongly recommended for normal operation. If these electrical characteristic conditions are also exceeded, the LSI will malfunction and cause poor reliability.

**DC Characteristics ( $V_{CC} = 2.7V$  to  $5.5V$ ,  $T_a = -20$  to  $+75^\circ C^{*3}$ )**

Item	Symbol	Min	Typ	Max	Unit	Test Condition	Notes*	
Input high voltage (1) (except OSC1)	VIH1	$0.7V_{CC}$	—	$V_{CC}$	V		6	
Input low voltage (1) (except OSC1)	VIL1	-0.3	—	$0.2V_{CC}$	V	$V_{CC} = 2.7$ to $3.0V$	6	
		-0.3	—	0.6	V	$V_{CC} = 3.0$ to $4.5V$		
Input high voltage (2) (OSC1)	VIH2	$0.7V_{CC}$	—	$V_{CC}$	V		15	
Input low voltage (2) (OSC1)	VIL2	—	—	$0.2V_{CC}$	V		15	
Output high voltage (1) (D0–D7)	VOH1	$0.75V_{CC}$	—	—	V	$-I_{OH} = 0.1$ mA	7	
Output low voltage (1) (D0–D7)	VOL1	—	—	$0.2V_{CC}$	V	$I_{OL} = 0.1$ mA	7	
Output high voltage (2) (except D0–D7)	VOH2	$0.8V_{CC}$	—	—	V	$-I_{OH} = 0.04$ mA	8	
Output low voltage (2) (except D0–D7)	VOL2	—	—	$0.2V_{CC}$	V	$I_{OL} = 0.04$ mA	8	
Driver ON resistance (COM)	$R_{COM}$	—	2	20	k $\Omega$	$\pm I_d = 0.05$ mA (COM) VLCD = 4V	13	
Driver ON resistance (SEG)	$R_{SEG}$	—	2	30	k $\Omega$	$\pm I_d = 0.05$ mA (SEG) VLCD = 4V	13	
I/O leakage current	$I_{LI}$	-1	—	1	$\mu A$	$V_{IN} = 0$ to $V_{CC}$	9	
Pull-up MOS current (D0–D7, RESET* pin)	-I <sub>p</sub>	10	50	120	$\mu A$	$V_{CC} = 3V$ $V_{IN} = 0V$		
Current consumption (HD66712U)	Normal display	$I_{CC}$	—	130	300	$\mu A$	$R_f$ oscillation external clock	10, 14
	LP mode1 (1/33duty)	$I_{LP1}$	—	90	—	$\mu A$	$V_{CC} = 3V$ $f_{osc} = 270$ kHz	
	LP mode2 (1/17duty)	$I_{LP2}$	—	65	—	$\mu A$		
LCD voltage	VLCD1	2.7	—	11.0	V	$V_{CC} - V_5$ , 1/5 bias	16	
	VLCD2	2.7	—	11.0	V	$V_{CC} - V_5$ , 1/6.7 bias	16	

Note: \* Refer to Electrical Characteristics Notes following these tables.

## HD66712U

### Booster Characteristics

Item	Symbol	Min	Typ	Max	Unit	Test Condition	Notes*
Output voltage (V5OUT2 pin)	VUP2	7.5	8.7	—	V	V <sub>ci</sub> = 4.5V, I <sub>o</sub> = 0.25 mA, C = 1 μF, f <sub>osc</sub> = 270 kHz T <sub>a</sub> = 25°C	18, 19
Output voltage (V5OUT3 pin)	VUP3	7.0	7.7	—	V	V <sub>ci</sub> = 2.7V, I <sub>o</sub> = 0.25 mA, C = 1 μF, f <sub>osc</sub> = 270 kHz T <sub>a</sub> = 25°C	18, 19
Input voltage	V <sub>ci</sub>	1.0	—	5.0	V	V <sub>ci</sub> ≤ V <sub>cc</sub> T <sub>a</sub> = 25°C	18, 19

Note: \* Refer to Electrical Characteristics Notes following these tables.

### AC Characteristics (V<sub>cc</sub> = 2.7V to 5.5V, T<sub>a</sub> = -20 to +75°C\*<sup>3</sup>)

#### Clock Characteristics (V<sub>cc</sub> = 2.7V to 5.5V, T<sub>a</sub> = -20 to +75°C\*<sup>3</sup>)

Item		Symbol	Min	Typ	Max	Unit	Test Condition	Notes*
External clock operation	External clock frequency	f <sub>cp</sub>	125	270	410	kHz		11
	External clock duty	Duty	45	50	55	%		
	External clock rise time	t <sub>rcp</sub>	—	—	0.2	μs		
	External clock fall time	t <sub>rcp</sub>	—	—	0.2	μs		
R <sub>i</sub> oscillation	Clock oscillation frequency	f <sub>osc</sub>	190	270	350	kHz	R <sub>i</sub> = 130 kΩ, V <sub>cc</sub> = 5V	HD66712U 12

Note: \* Refer to the Electrical Characteristics Notes section following these tables.

**System Interface Timing Characteristics (1) ( $V_{CC} = 2.7V$  to  $4.5V$ ,  $T_a = -20$  to  $+75^{\circ}C^{*3}$ )**
**Bus Write Operation**

Item	Symbol	Min	Typ	Max	Unit	Test Condition
Enable cycle time	$t_{cycE}$	1000	—	—	ns	Figure 34
Enable pulse width (high level)	$PW_{EH}$	450	—	—		
Enable rise/fall time	$t_{Er}$ , $t_{Ef}$	—	—	25		
Address set-up time (RS, R/W to E)	$t_{AS}$	60	—	—		
Address hold time	$t_{AH}$	20	—	—		
Data set-up time	$t_{DSW}$	195	—	—		
Data hold time	$t_H$	10	—	—		

**Bus Read Operation**

Item	Symbol	Min	Typ	Max	Unit	Test Condition
Enable cycle time	$t_{cycE}$	1000	—	—	ns	Figure 35
Enable pulse width (high level)	$PW_{EH}$	450	—	—		
Enable rise/fall time	$t_{Er}$ , $t_{Ef}$	—	—	25		
Address set-up time (RS, R/W to E)	$t_{AS}$	60	—	—		
Address hold time	$t_{AH}$	20	—	—		
Data delay time	$t_{DDR}$	—	—	360		
Data hold time	$t_{DHR}$	5	—	—		

---

## HD66712U

---

### Serial Interface Operation

Item	Symbol	Min	Typ	Max	Unit	Test Condition
Serial clock cycle time	$t_{SCYC}$	1	—	20	$\mu$ s	Figure 36
Serial clock (high level width)	$t_{SCH}$	400	—	—	ns	
Serial clock (low level width)	$t_{SCL}$	400	—	—		
Serial clock rise/fall time	$t_{SCr}, t_{SCf}$	—	—	50		
Chip select set-up time	$t_{CSU}$	60	—	—		
Chip select hold time	$t_{CH}$	200	—	—		
Serial input data set-up time	$t_{SISU}$	200	—	—		
Serial input data hold time	$t_{SIH}$	200	—	—		
Serial output data delay time	$t_{SOD}$	—	—	360		
Serial output data hold time	$t_{SOH}$	0	—	—		

---

**System Interface Timing Characteristics (2) ( $V_{CC} = 4.5V$  to  $5.5V$ ,  $T_a = -20$  to  $+75^{\circ}C^{*3}$ )**
**Bus Write Operation**

Item	Symbol	Min	Typ	Max	Unit	Test Condition
Enable cycle time	$t_{cycE}$	500	—	—	ns	Figure 34
Enable pulse width (high level)	$PW_{EH}$	230	—	—		
Enable rise/fall time	$t_{Er}, t_{Ef}$	—	—	20		
Address set-up time (RS, R/W to E)	$t_{AS}$	40	—	—		
Address hold time	$t_{AH}$	10	—	—		
Data set-up time	$t_{DSW}$	80	—	—		
Data hold time	$t_H$	10	—	—		

**Bus Read Operation**

Item	Symbol	Min	Typ	Max	Unit	Test Condition
Enable cycle time	$t_{cycE}$	500	—	—	ns	Figure 35
Enable pulse width (high level)	$PW_{EH}$	230	—	—		
Enable rise/fall time	$t_{Er}, t_{Ef}$	—	—	20		
Address set-up time (RS, R/W to E)	$t_{AS}$	40	—	—		
Address hold time	$t_{AH}$	10	—	—		
Data delay time	$t_{DDR}$	—	—	160		
Data hold time	$t_{DHR}$	5	—	—		

## HD66712U

### Serial Interface Sequence

Item	Symbol	Min	Typ	Max	Unit	Test Condition
Serial clock cycle time	$t_{SCYC}$	0.5	—	20	$\mu$ s	Figure 36
Serial clock (high level width)	$t_{SCH}$	200	—	—	ns	
Serial clock (low level width)	$t_{SCL}$	200	—	—		
Serial clock rise/fall time	$t_{SCr}, t_{SCf}$	—	—	50		
Chip select set-up time	$t_{CSU}$	60	—	—		
Chip select hold time	$t_{CH}$	100	—	—		
Serial input data set-up time	$t_{SISU}$	100	—	—		
Serial input data hold time	$t_{SIH}$	100	—	—		
Serial output data delay time	$t_{SOD}$	—	—	160		
Serial output data hold time	$t_{SOH}$	0	—	—		

### Segment Extension Signal Timing ( $V_{CC} = 2.7V$ to $5.5V$ , $T_a = -20$ to $+75^\circ C^{*3}$ )

Item		Symbol	Min	Typ	Max	Unit	Test Condition
Clock pulse width	High level	$t_{CWH}$	800	—	—	ns	Figure 37
	Low level	$t_{CWL}$	800	—	—		
Clock set-up time		$t_{CSU}$	500	—	—		
Data set-up time		$t_{SU}$	300	—	—		
Data hold time		$t_{DH}$	300	—	—		
M delay time		$t_{DM}$	-1000	—	1000		
Clock rise/fall time		$t_{ct}$	—	—	100		

### Reset Timing ( $V_{CC} = 2.7V$ to $5.5V$ , $T_a = -20$ to $+75^\circ C^{*3}$ )

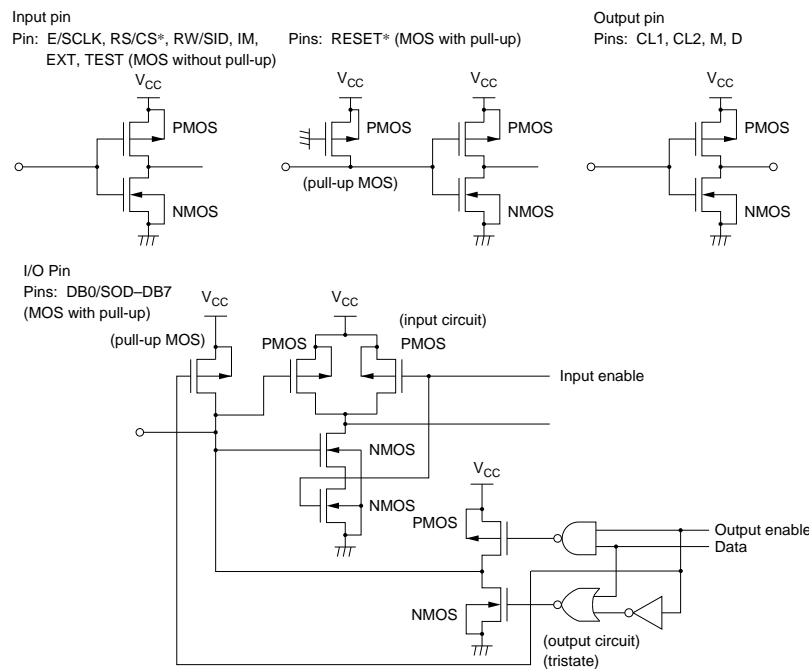
Item	Symbol	Min	Typ	Max	Unit	Test Condition
Reset low-level width	$t_{RES}$	10	—	—	ms	Figure 38

### Power Supply Conditions Using Internal Reset Circuit

Item	Symbol	Min	Typ	Max	Unit	Test Condition
Power supply rise time	$t_{rCC}$	0.1	—	10	ms	Figure 39
Power supply off time	$t_{OFF}$	1	—	—		

**Electrical Characteristics Notes**

1. All voltage values are referred to GND = 0V. If the LSI is used above the absolute maximum ratings, it may become permanently damaged. Using the LSI within the following electrical characteristic is strongly recommended to ensure normal operation. If these electrical characteristic are also exceeded, the LSI may malfunction or exhibit poor reliability.
2.  $V_{CC} \geq V1 \geq V2 \geq V3 \geq V4 \geq V5$  must be maintained.
3. For die products, specified up to 75°C.
4. For die products, specified by the die shipment specification.
5. The following four circuits are I/O pin configurations except for liquid crystal display output.

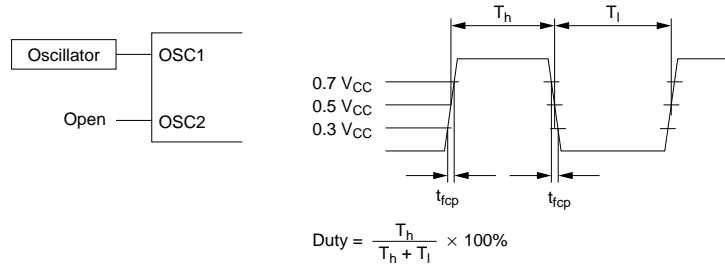


6. Applies to input pins and I/O pins, excluding the OSC1 pin.
7. Applies to I/O pins.
8. Applies to output pins.
9. Current flowing through pull-up MOSs, excluding output drive MOSs.

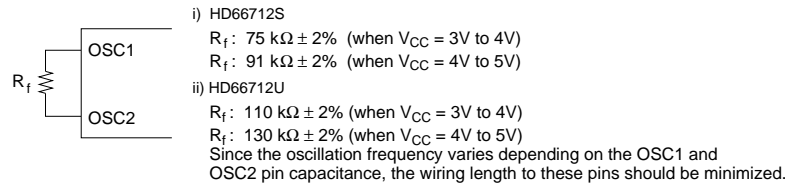
# HD66712U

10. Input/output current is excluded. When input is at an intermediate level with CMOS, the excessive current flows through the input circuit to the power supply. To avoid this from happening, the input level must be fixed high or low.

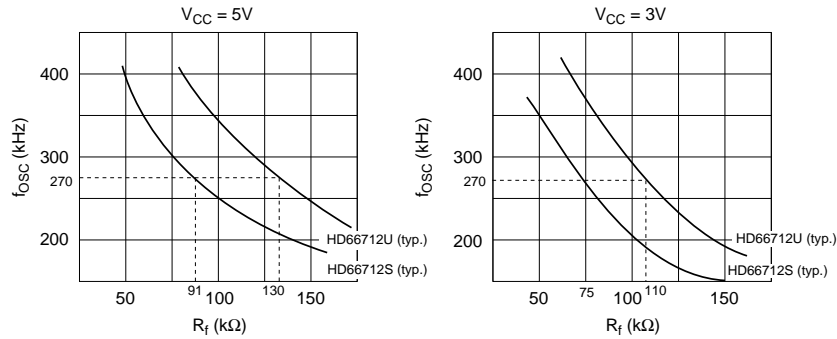
11. Applies only to external clock operation.



12. Applies only to the internal oscillator operation using oscillation resistor  $R_f$ .



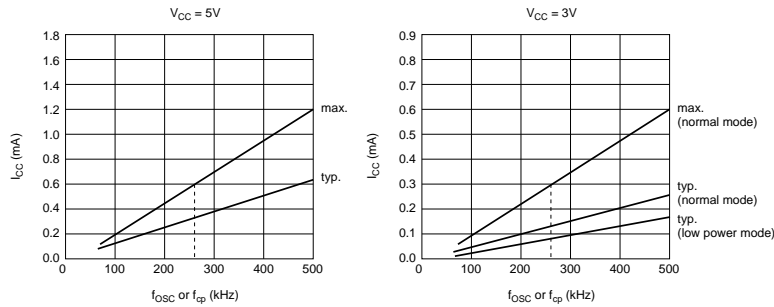
Referential data



13.  $R_{COM}$  is the resistance between the power supply pins ( $V_{CC}$ , V1, V4, V5) and each common signal pin (COM0 to COM33).

$R_{SEG}$  is the resistance between the power supply pins ( $V_{CC}$ , V2, V3, V5) and each segment signal pin (SEG1 to SEG60).

14. The following graphs show the relationship between operation frequency and current consumption.

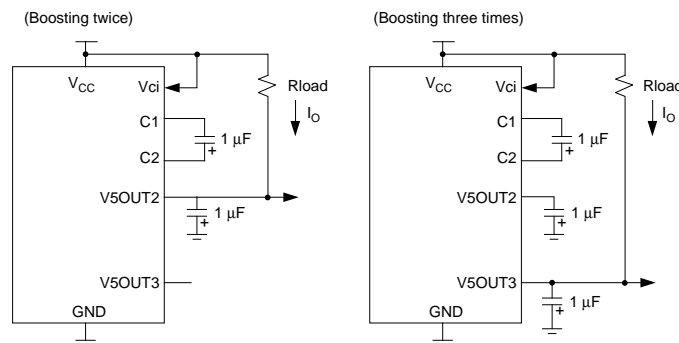


15. Applies to the OSC1 pin.

16. Each COM and SEG output voltage is within  $\pm 0.15V$  of the LCD voltage ( $V_{CC}$ , V1, V2, V3, V4, V5) when there is no load.

17. The TEST pin must be fixed to ground, and the IM or EXT pin must also be connected to  $V_{CC}$  or ground.

18. Booster characteristics test circuits are shown below.



# HD66712U

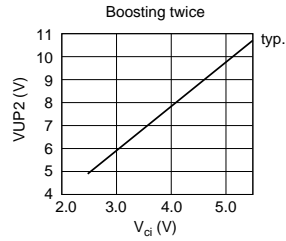
## 19. Reference data

The following graphs show the liquid crystal voltage booster characteristics.

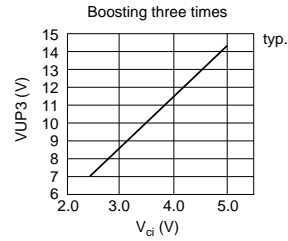
$$VUP2 = V_{CC} - V5OUT2$$

$$VUP3 = V_{CC} - V5OUT3$$

(1) VUP2, VUP3 vs V<sub>ci</sub>

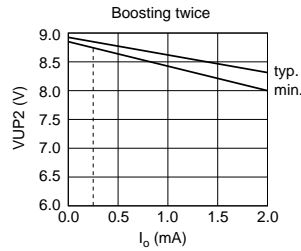


Test condition: V<sub>ci</sub> = V<sub>CC</sub>, f<sub>cp</sub> = 270 kHz,  
T<sub>a</sub> = 25°C, R<sub>load</sub> = 25 kΩ

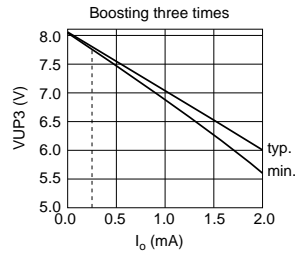


Test condition: V<sub>ci</sub> = V<sub>CC</sub>, f<sub>cp</sub> = 270 kHz,  
T<sub>a</sub> = 25°C, R<sub>load</sub> = 25 kΩ

(2) VUP2, VUP3 vs I<sub>o</sub>

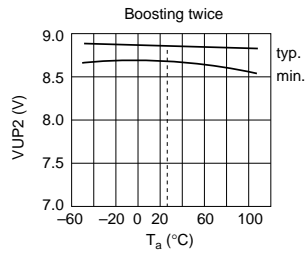


Test condition: V<sub>ci</sub> = V<sub>CC</sub> = 4.5V,  
R<sub>f</sub> = 91 kΩ, T<sub>a</sub> = 25°C

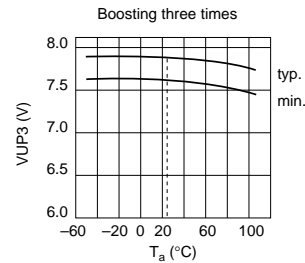


Test condition: V<sub>ci</sub> = V<sub>CC</sub> = 2.7V,  
R<sub>f</sub> = 75 kΩ, T<sub>a</sub> = 25°C

(3) VUP2, VUP3 vs T<sub>a</sub>

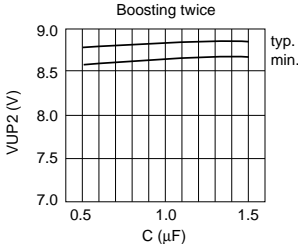


Test condition: V<sub>ci</sub> = V<sub>CC</sub> = 4.5V,  
R<sub>f</sub> = 91 kΩ, I<sub>o</sub> = 0.25 mA

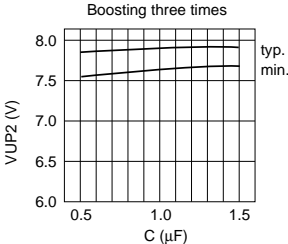


Test condition: V<sub>ci</sub> = V<sub>CC</sub> = 2.7V,  
R<sub>f</sub> = 75 kΩ, I<sub>o</sub> = 0.25 mA

(4) VUP2, VUP3 vs capacitance



Test condition:  $V_{ci} = V_{CC} = 4.5V$ ,  
 $R_f = 91\text{ k}\Omega$ ,  $I_o = 0.25\text{ mA}$



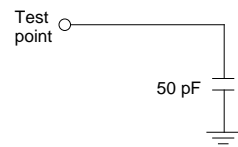
Test condition:  $V_{ci} = V_{CC} = 2.7V$ ,  
 $R_f = 75\text{ k}\Omega$ ,  $I_o = 0.25\text{ mA}$

20. Must maintain (“High”)  $V_{CC} \geq V_{ci}$  (“Low”).

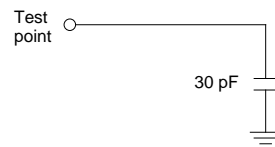
## Load Circuits

### AC Characteristics Test Load Circuits

Data bus: DB0-DB7, SOD



Segment extension signals: CL1, CL2, D, M



Timing Characteristics

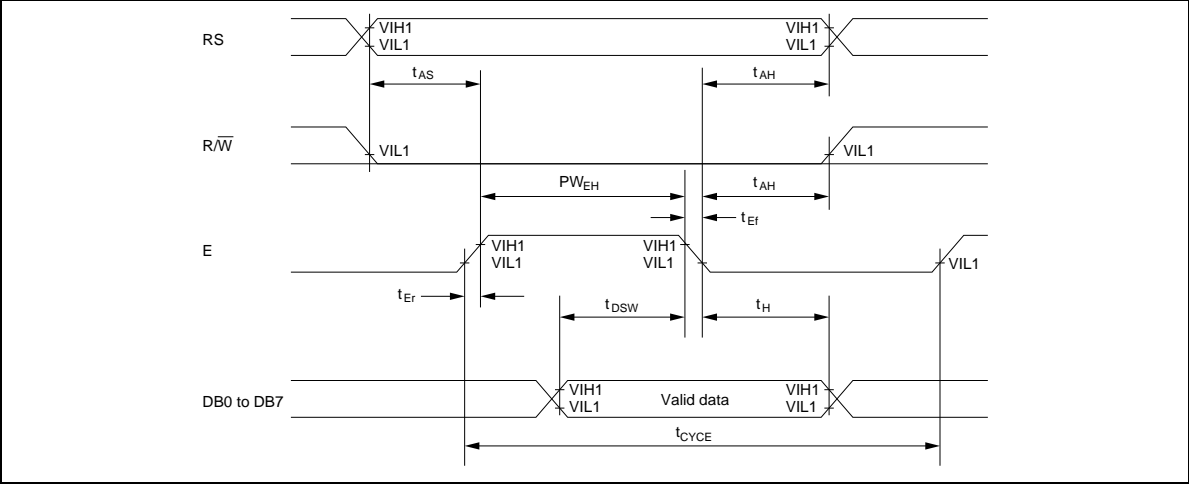


Figure 34 Bus Write Operation

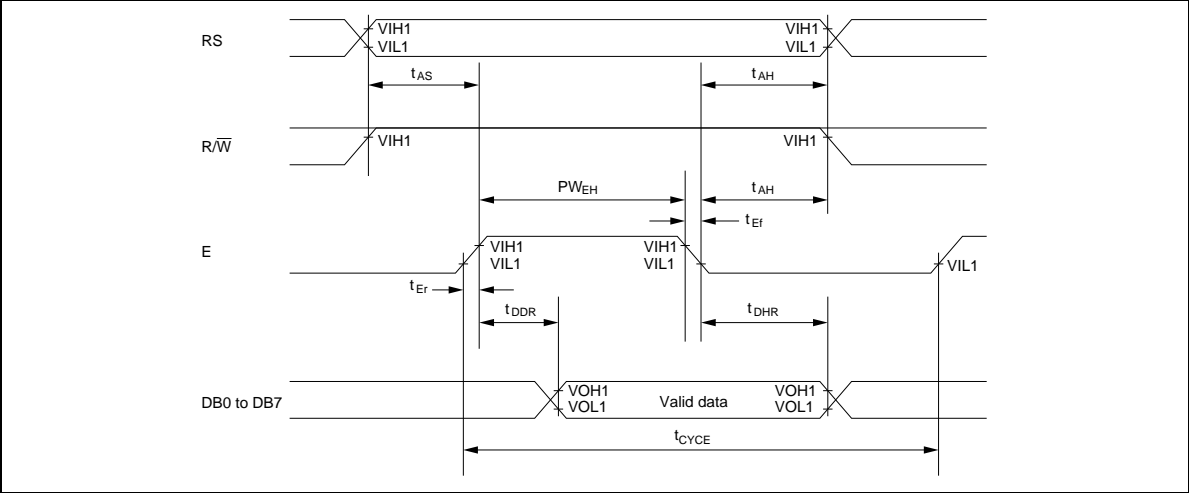


Figure 35 Bus Read Operation

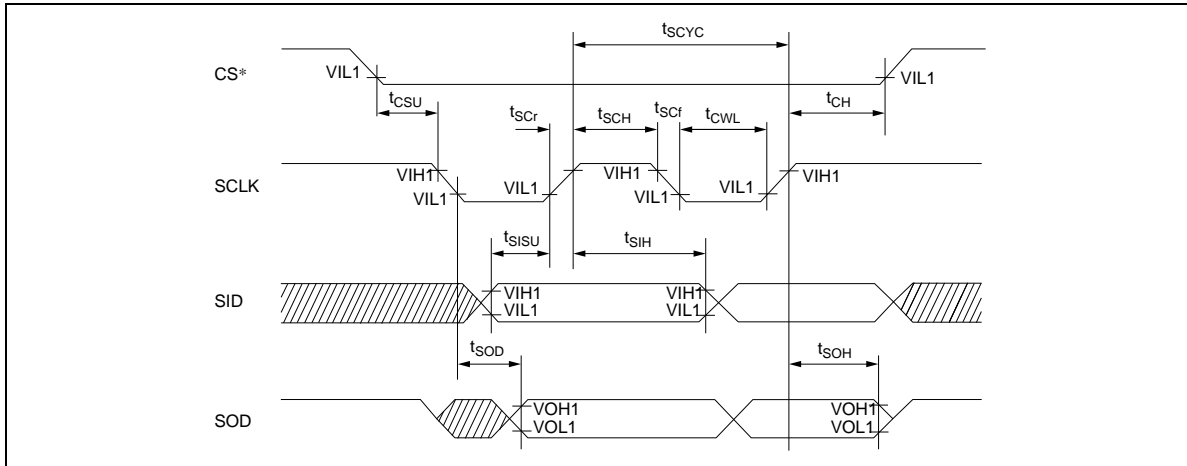


Figure 36 Serial Interface Timing

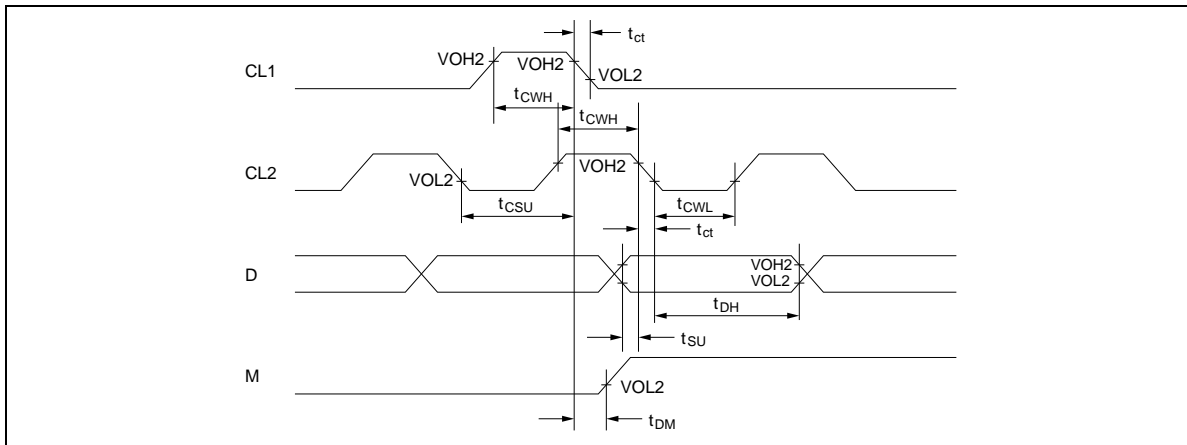


Figure 37 Interface Timing with Extension Driver

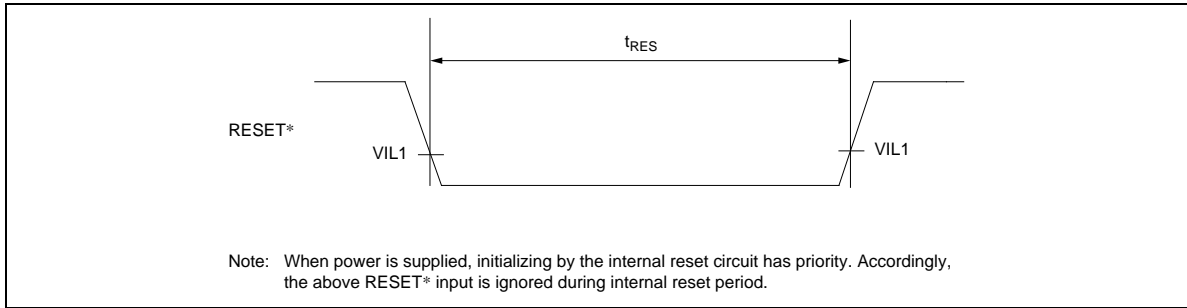


Figure 38 Reset Timing

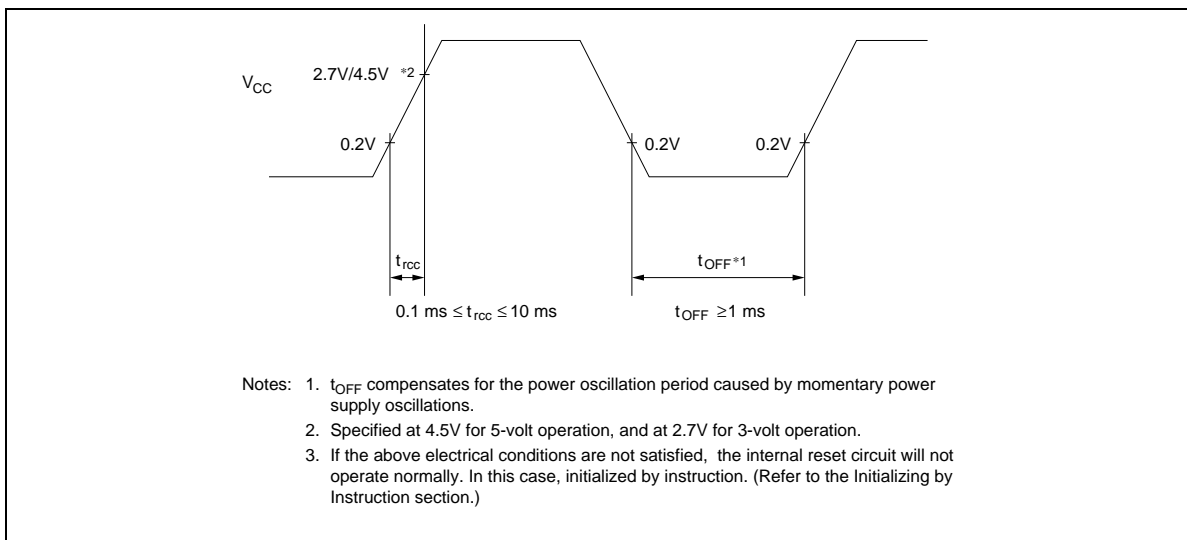


Figure 39 Power Supply Sequence