

SPECIFICATION FOR APPROVAL

Product Name	TOROIDAL INDUCTOR	Page	1
Tai-tech Part No.	TC0806 Series	Rev. No.	0

1. CONFIGURATION & DIMENSIONS :

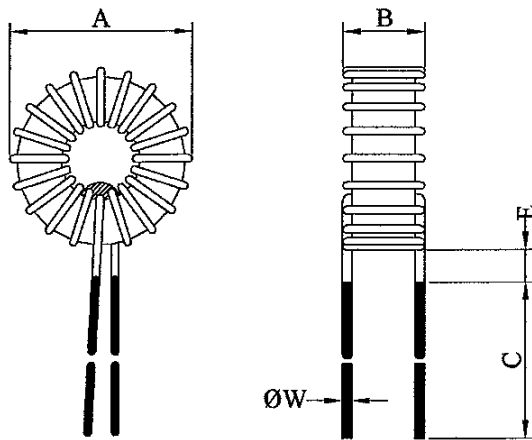

A	:	8.50 MAX	m/m
B	:	6.00 MAX	m/m
C	:	10.00±3.0	m/m
E	:	1.00 MAX	m/m
ØW	:	0.40 REF	m/m

2. SCHEMATIC DIAGRAM :

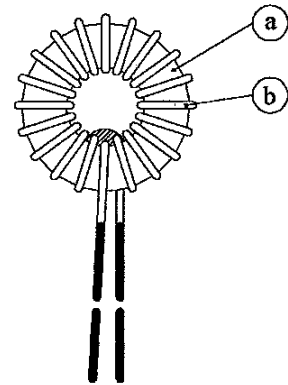
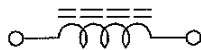

3. MATERIALS :

NO.	DESCRIPTION	SPECIFICATION	REMARK
a.	CORE	IRON POWDER CORE	
b.	WIRE	ENAMELLED COPPER WIRE	

4. GENERAL SPECIFICATION :

- a. TEMP. RISE : 40°C MAX AT I_{rms}.
- b. STORAGE TEMP. : -40°C ---- +125°C
- c. OPERATING TEMP. : -25°C---- +105°C



TAI-TECH ADVANCED ELECTRONICS (S) PTE LTD

SPECIFICATION FOR APPROVAL

Product Name	TOROIDAL INDUCTOR	Page	2
Tai-tech Part No.	TC0806 Series	Rev. No.	0

5. ELECTRICAL CHARACTERISTICS & MECHANICAL DIMENSIONS :

PART No.	L (μ H) $\pm 20\%$	RDC (m Ω) MAX.	I _{rms} (A)	I _{sat} (A)
TC0806-120M-26	12.5	35	3.0	1.50
TC0806-120M-52	12.5	35	3.0	1.80

