

SERIES RIM8500

NorthStar™ brand

Bearingless Encoder

Key Features

- Compact, Bearingless Design Mounts to 180-C Face Motors
- Sensor Modules are Removable On-The-Fly and Require No Gapping
- Stainless Steel and Ductile Cast Iron Construction for Harsh Mill Environments
- Magneto-Resistive Technology Resists Dust, Dirt, Oil, Water and Other Common Contaminants

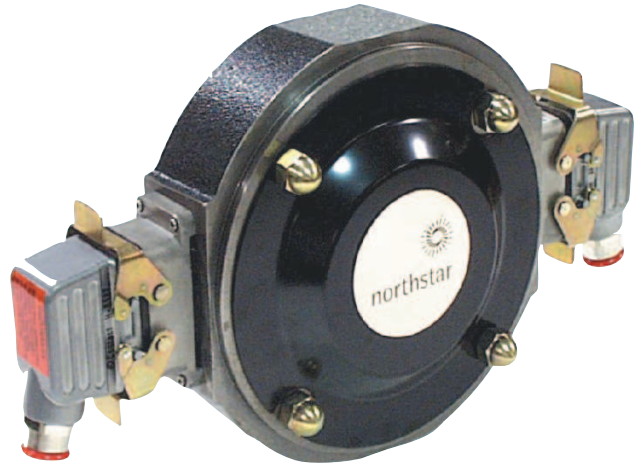

SPECIFICATIONS

STANDARD OPERATING CHARACTERISTICS

Code: Incremental
Pulses per Revolution: 60-1200
Phasing Sense: A leads B for Counter-Clockwise rotation (CCW) viewing encoder-mounted end
Quadrature Phasing: $90^\circ \pm 22^\circ$
Symmetry: $180^\circ \pm 54^\circ$
Index: 270° , ungated (optional gated to falling B edge)

ELECTRICAL

Input Power Requirements: 5-15 Volts DC, 45 mA typical per sensor module plus line driver load
Output Signals: Line Driver, 150mA source/sink
Frequency Response: 0 - 120kHz Data & Index
Electrical Immunity: 2kV ESD, Reverse Polarity, Short Circuit
Connector: 10 pin industrial duty latching, sealed NEMA 4 & 12, IP65

MECHANICAL

Shaft Speed: 7,000 RPM
Mounting Configuration: 8.5" 180C face mount for NEMA MG1 standards
Housing Material: Cast Iron/Stainless Steel
Acceleration Rate: 3600 rpm/sec max
Shaft Length Required: 2.5" min
Allowable Shaft End-Play: $\pm 0.050"$
Allowable Shaft Runout: 0.003" TIR

ENVIRONMENTAL

Operating Temperature Range:
 Standard: -40°C to $+90^\circ\text{C}$
 Extended: -40°C to $+100^\circ\text{C}$
Storage Temperature Range: -40°C to $+120^\circ\text{C}$
Humidity: to 98% RH (non-condensing)
Shock (Sensor Module): 1 meter drop test, 30 G's Min
Vibration: 18 G's @ 5-2000 Hz spectrum

ELECTRICAL CONNECTIONS

Signal	Connector Pin	Pigtail Cable	MS 3102E18-IT#
Common	1	Black	A
B	2	Green	E
A	3	Blue	D
Z *	4	Violet	C
No Connection	5	—	—
Vcc (5-15 VDC)	6	Red	B
B̄	7	Yellow	H
Ā	8	Gray	G
Z *	9	Orange	I
Shield	10	Braid	J

* Index (Z) optional. See Ordering Information

Ordering Information

To order, complete the model number with code numbers from the table below:

Code 1: Model	Code 2: PPR	Code 3: Index	Code 4: Wheel Bore	Code 5: Output	Code 6: Electrical	Code 7: Termination
R8	<input type="checkbox"/> <input type="checkbox"/> <input type="checkbox"/> <input type="checkbox"/>	<input type="checkbox"/>	<input type="checkbox"/> <input type="checkbox"/> <input type="checkbox"/>	<input type="checkbox"/>	<input type="checkbox"/>	<input type="checkbox"/>

Ordering Information

R8 Motor Mount Ring, for Nema 8 1/2" C-Face Motors (180C)	0060	0300	L No Index Available when Code 2 is 0480, 0512, 0600, 0960 1024 or 1200 G Gated Index (Z, Z̄) Z Differential Index (Z, Z̄)	J04 5/8" bore	1 Single 2 Dual (Isolated) Differential, bidirectional signals (A, Ā, B, B̄)	L 5-15V in, 5-15V Line Driver (4428) out H Same as L with extended temp. to 100°C R 15-26V in, 15V Line Driver (4428) out 5 5-15V in, 5V Line Driver (4428) out	C Latching Industrial Connector with 1/2" NPT M 10 pin MS Connector P 18" Pigtail Q Latching industrial connector on 18" cable
	0064	0480		J05 7/8" bore			
	0075	0512		J06 1.00" bore			
	0120	0600		J07 1-1/8" bore			
	0128	0960		K09 1-3/8" bore			
	0128	0960		K10 1-1/2" bore			
	0150	1024		K11 1-5/8" bore			
	0240	1200		K12 1-3/4" bore			
	0256			K13 1-7/8" bore			
				K14 2" bore			
				K15 2-1/8" bore			
				K16 2-1/4" bore			
				K17 2-3/8" bore			
				K18 2-1/2" bore			
				K19 2-7/8" bore			
				Additional Shaft Sizes Available Up to 3.75" Maximum			
				End of shaft mounting for GE & Emerson Motors			
				E01 1.125" EOS			
				E06 2.125" EOS			
				E08 2.375" EOS			
				E10 2.875" EOS			

Note: See ACCESSORIES Section For Connectors, Spare Parts and Pulse Wheels

DIMENSIONS ^{inch} [mm]

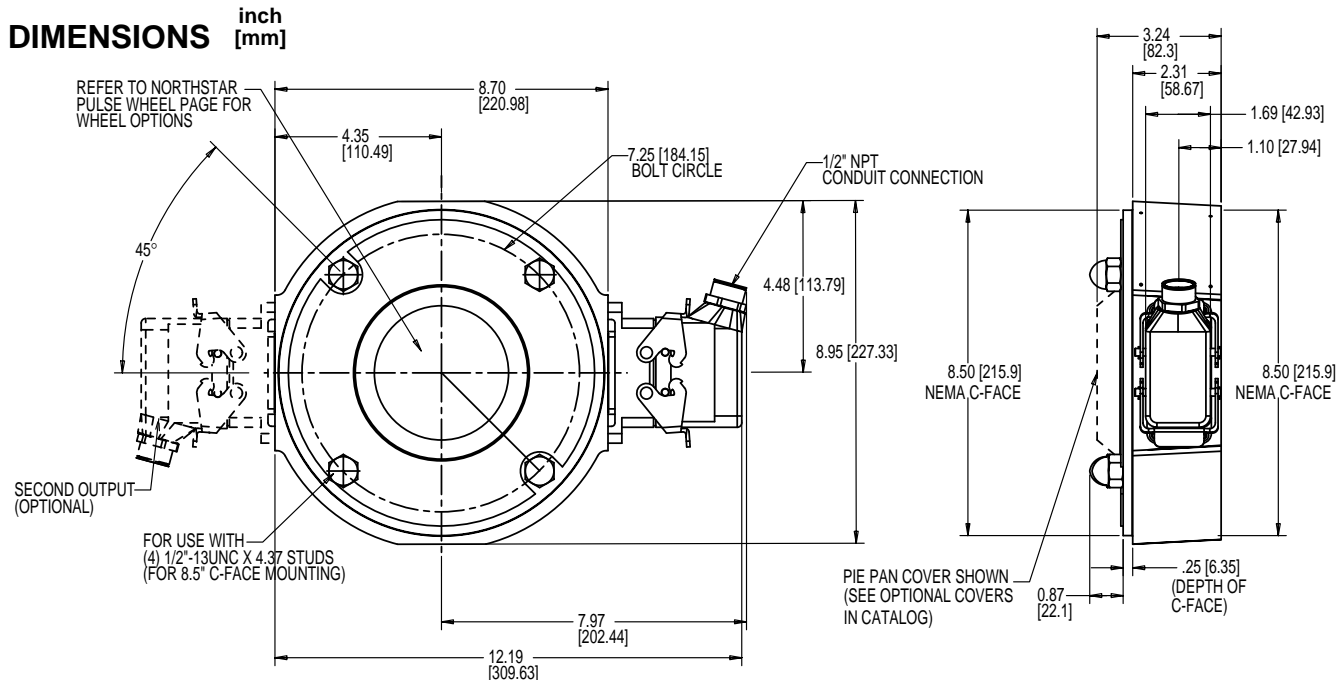

Worldwide Brands: NorthStar™ • Acuro™ • Dynapar™ • Hengstler™ • Harowe™

DYNAPAR
INNOVATION - CUSTOMIZATION - DELIVERY
WWW.DYNAPAR.COM

Headquarters: 1675 Delany Road • Gurnee, IL 60031-1282 • USA

Customer Service:
Tel.: +1.800.873.8731
Fax: +1.847.662.4150
custserv@dynapar.com

Technical Support
Tel.: +1.800.234.8731
Fax: +1.847.662.4150
northstar.techsupport@dynapar.com

European Sales Representative
Hengstler GmbH
Uhlandstrasse 49, 78554 Aldingen
Germany
www.hengstler.com