

SERIES M15

Dynapar™ brand

For Stepper & Small Servo Motors

Key Features

- **Modular Encoder with Easy Installation Requiring No Special Gapping Tools or Parts**
- **Phased Array Sensor Technology Allowing .030" Axial Shaft Play**
- **Wide -20 to 120C Operating Temperature Range**

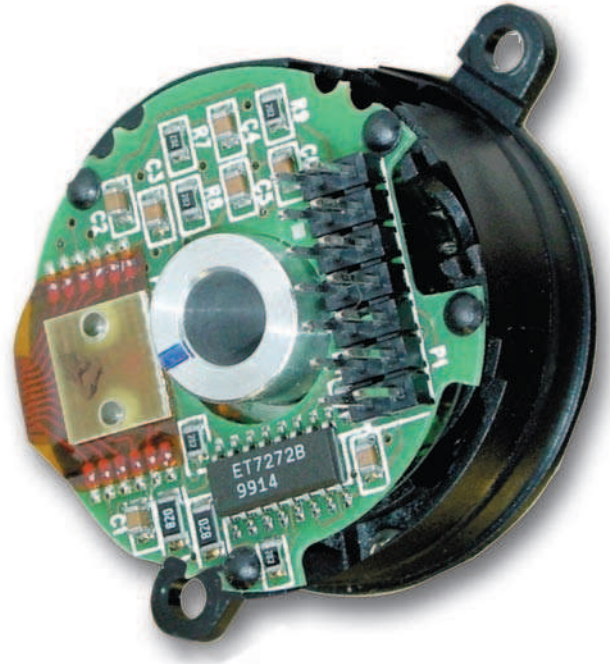

SPECIFICATIONS

STANDARD OPERATING CHARACTERISTICS

Code: Incremental

Resolution: (pulses/revolution)

Incremental: 200 to 1024 PPR;

Commutation: 4, 6, or 8 pole

Accuracy:

Incremental: ± 5 arc-mins. max. edge to edge;

Commutation: ± 6 arc-mins. max.

Sense: (viewing encoder mounting surface)

Incremental: A leads B by 90° for CCW rotation of motor shaft;

Commutation: U leads V, V leads W by 120° for CW rotation of motor shaft

Phasing:

Incremental: 90° $\pm 18^\circ$ electrical

Commutation: 8 Pole: 30°; 6 Pole: 40°; 4 Pole: 60° mechanical

Index to U Channel: $\pm 1^\circ$ mechanical - Index center to U channel edge

Symmetry:

Incremental: 180° $\pm 18^\circ$ electrical

Commutation: 8 Pole: 45°; 6 Pole: 60°; 4 Pole: 90° mechanical

Index Pulse Width: 180° $\pm 36^\circ$ electrical (Gated with B low) standard

ELECTRICAL

Input Power Requirements:

Incremental: 5 or 12 VDC $\pm 10\%$ at 100 mA max. (excluding output load);

Incremental w/Commutation: 5 or 12 VDC $\pm 10\%$ at 120 mA max. (excluding output load)

Output Signals:

7272 Line Driver: 40 mA sink/source max.;

Open Collector w/2.0 k Ω pull-ups: 16 mA sink max.

Frequency Response: 200 kHz min.

Termination:

Connector: PCB mounted dual row head with 0.1" x 0.1" pin spacing, 10 pins (incremental only), 14 pins (w/commutation);

Cable: conductors - 28 AWG, stranded (7/36), insulation - black, PVC; Shield: aluminum/polyester foil plus tinned, copper drain wire (28 AWG, 7/36)

Noise Immunity: Conforms to EN50082-1 Light Industrial for Electro-Static Discharge, Radio Frequency Interference, Electrical Fast Transients, and Magnetic Fields (for models or applications with shielded cable)

MECHANICAL

Weight:

Connector: 0.8 oz. (23 gm) typ.

Connector w/cover: 1.0 oz. (28 gm) typ.

Cable: 1.3 oz (37 gm) typ.

Cable w/cover: 1.5 oz. (43 gm) typ.

Dimensions:

Outside Diameter: 1.60" (40.7 mm) max. w/cover,

1.50" (38.2 mm) max. without cover;

Height: 1.27" (32.3 mm) max. (w/cover, excluding connector);

Emitter to Detector Gap: 0.070" (1.8 mm) min.

Material:

Base, Housing, & Cover: high temperature, glass filled polymer;

Hub: Aluminum; Disk: 0.030" thick glass

Finish:

Base & Housing: black;

Cover: RAL 7010 (dark grey)

Moment of Inertia: 3.40 x 10⁻⁵ in-oz sec.² (2.4 gm-

cm²)

Hub Diameters: 1/8", 1/4", 3/8", 3/16", 6 mm,

8 mm, 10 mm nominal

Hub Dia. Tolerance: +0.001"/-0.000" (+0.026 mm/-0.000 mm)

Mating Shaft Length: 0.45" (12 mm) min.; 0.85" (22 mm) max. inside cover

Mating Shaft Runout: 0.002" (0.05 mm) max.

(Includes shaft perpendicularity to mounting surface)

Mating Shaft Endplay: +0.015"/-0.015" (+0.38 mm/-0.38 mm) nominal ("+" indicates away from mounting face)

Mounting:

Base: (2) #4-40 (M2.5) #1 Phillips fillister head cap screw on 1.812" (46 mm) B.C., or (2) #2-56 (M2.0)

hex socket cap screw on 1.28" (32.5 mm) B.C.; 0.01" (0.254 mm) true position to shaft.

Shaft: split hub w/collar clamp, #2-56 hex socket cap screw (5/64" hex wrench included)

Electrical/Mechanical Alignment Range: $\pm 15^\circ$ mechanical

Acceleration: 100,000 rad/sec.² max.

Velocity: 12,000 RPM max.

ENVIRONMENTAL

Operating Temperature: 0° to 120°C

Storage Temperature: -40° to 85°C

Shock: 50 G's for 11 msec duration

Vibration: 2.5 G's at 5 to 2000 Hz

Relative Humidity: 90% non-condensing

Enclosure Rating: NEMA 1 / IP40 dirt-tight (for models with cover)



Satellite Locations:

- **North America:** North Carolina, South Carolina, Connecticut, Massachusetts, New York, Canada, British Virgin Islands
- **West Indies:** St. Kitts • **Europe:** United Kingdom, Italy, France, Germany, Spain, Slovakia
- **South America:** Brazil • **Asia:** China, Japan, Korea, Singapore

Worldwide Brands: NorthStar™ • Acuro™ • Dynapar™ • Hengstler™ • Harowe™

Headquarters: 1675 Delany Road • Gurnee, IL 60031-1282 • USA • Phone: 1.847.662.2666 • Fax: 1.847.662.6633

Customer Service:

Tel.: +1.800.873.8731

Fax: +1.847.662.4150

custserv@dynapar.com

Technical Support

Tel.: +1.800.234.8731

Fax: +1.847.782.5277

dynapar.techsupport@dynapar.com

Dynapar™ brand is a trademark of DYNAPAR. All rights reserved.
Specifications subject to change without notice.
Document No. 702164-0002, Rev.- ©2010 Dynapar

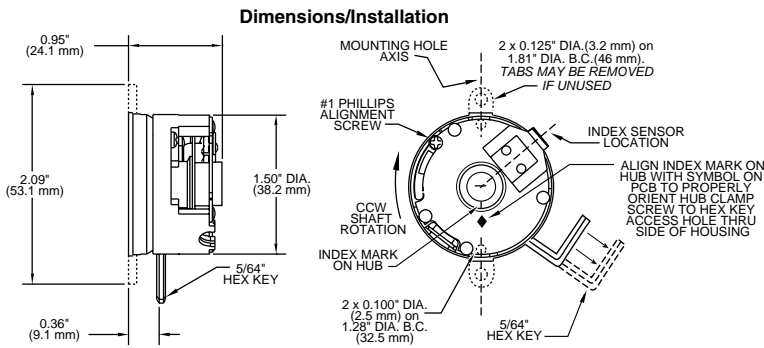

Output Waveforms (For clarity, compliments are not shown.)

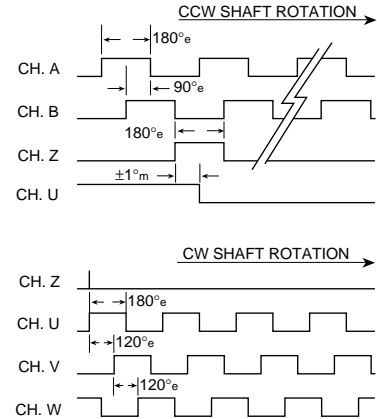

Installation Instructions:

Incremental only models: Drawing #200638-0001
Commutation models: Drawing #200638-0002

Code 6: Terminations (Not all signals present on all models)

Pin	10 Pin		14 Pin	
	O.C.	L.D.	O.C.	L.D.
1	A	—	Vcc	—
2	Vcc	Vcc	U	—
3	GND	GND	U'	—
4	—	—	V	—
5	—	A'	V'	—
6	—	A	W	—
7	—	B'	W'	—
8	B	B	A'	—
9	—	Z'	A	—
10	Z	Z	B	—
11	—	—	B'	—
12	—	—	Z	—
13	—	—	GND	—
14	—	—	Z'	—

Mating Cable Assembly:

10 pin, 109524-000x
14 pin, 110527-000x
x = length in feet

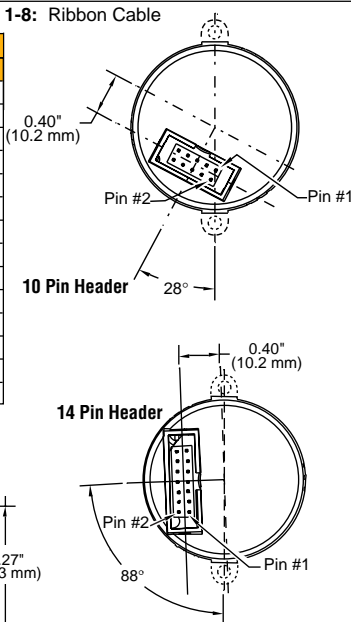
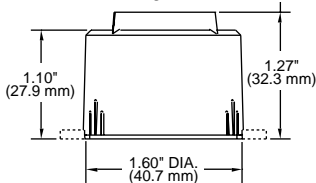

Function	Wire Color	
	Incr. Only	Incr. & Comm.
Vcc com	—	RED/WHT
Vcc Inc	RED	RED
GND Inc	BLK	BLK
GND com	—	BLK/WHT
A'	RED/BLK	BLU/BLK
A	GRN	BLU
B'	WHT/BLK	GRN/BLK
B	ORN	GRN
Z'	BLU	VIO/BLK
Z	WHT	VIO
U'	—	BRN/BLK
U	—	BRN
V'	—	GRY/BLK
V	—	GRY
W'	—	WHT/BLK
W	—	WHT

A-H: Shielded Cable

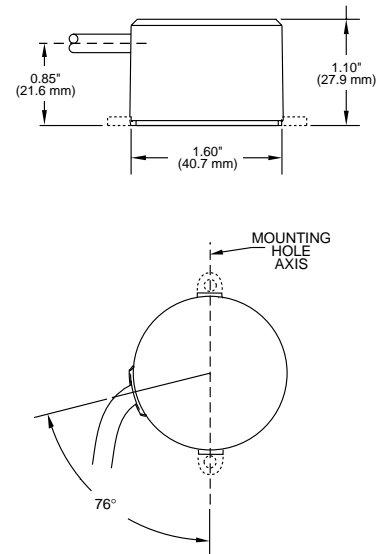

Ordering Information

To order, complete the model number with code numbers from the table below:

Code 1: Model	Code 2: PPR, Poles	Code 3: Cover	Code 4: Electrical	Code 5: Hub	Code 6: Termination
M15	<input type="checkbox"/> <input type="checkbox"/> <input type="checkbox"/> <input type="checkbox"/> / <input type="checkbox"/>	<input type="checkbox"/>	<input type="checkbox"/>	<input type="checkbox"/>	<input type="checkbox"/>

Ordering Information						
M15	Size 15 Commutating Modular	Incremental channels only	0 No cover 1 Enclosed, end-of-shaft mount 2 Through shaft	0 5V in, open collector out incremental only 1 12V in, open collector out incremental only 3 5V in, line driver out incremental only Available when Code 2 is XXXX/4, XXXX/6, or XXXX/8 6 5V in, line driver out incr.; 5V in, open collector out comm. 7 5V in, line driver out incr.; 12V in, open collector out comm. 9 5V in, line driver out incr.; 5V in, line driver out comm.	0 1/4 in. 1 3/8 in. 4 6 mm 5 8 mm 6 10 mm 8 3/16 in. 9 1/8 in.	Available when Code 4= 0,1,3,6 or 9
		Incremental plus Commutation channels				0200/0 1000/0 0400/0 1024/0 0500/0
		0500/6 1024/4 1000/4 1024/6 1000/6 1024/8 1000/8				Available when Code 4= 0 - 9
						A-H Shielded cable; A=1 ft., B=2 ft., etc.