

DZ2S68000L

Silicon epitaxial planar type

For ESD protection

■ Features

- High ESD
- Halogen-free / RoHS compliant
(EU RoHS / UL-94 V-0 / MSL:Level 1 compliant)

■ Marking Symbol: UG

■ Packaging

Embossed type (Thermo-compression sealing) 3 000 pcs / reel (standard)

■ Absolute Maximum Ratings Ta = 25 °C

Parameter	Symbol	Rating	Unit
Total power dissipation ^{*1}	PT	150	mW
Electrostatic discharge ^{*2}	ESD	±8	kV
Junction temperature	Tj	150	°C
Storage temperature	Tstg	-55 to +150	°C

Note) *1 Mounted on glass epoxy print board. (45 mm x 45 mm x 1 mm)

Soldering size : 0.8 x 0.6 mm

*2 Test method:IEC61000_4_2

(C = 150 pF , R = 330 Ω , Contact and Air discharge : 10 times)

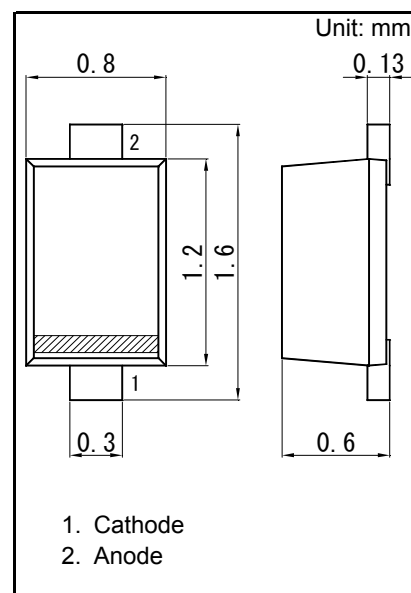

Panasonic	SSMini2-F5-B
JEITA	SC-79
Code	SOD-523

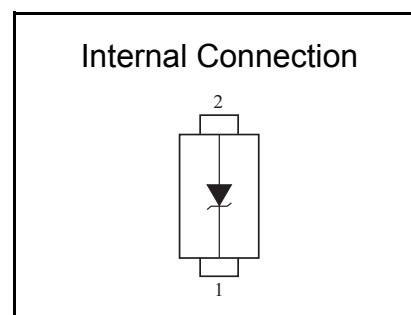

■ Electrical Characteristics Ta = 25 °C ± 3 °C

Parameter	Symbol	Conditions	Min	Typ	Max	Unit
Zener voltage ^{*1, *2}	VZ	IZ = 2 mA	63.0	68.0	73.0	V
Reverse current	IR	VR = 52 V			0.05	μA
Terminal capacitance	Ct	VR = 0 V, f = 1 MHz		13		pF
Temperature coefficient of zener voltage ^{*3}	SZ	IZ = 2 mA		45.0		mV/°C

Note) 1. Measuring methods are based on JAPANESE INDUSTRIAL STANDARD JIS C 7031 Measuring methods for Diodes.

2. Absolute frequency of input and output is 5 MHz.

3. *1 The temperature must be controlled 25 °C for VZ measurement.

VZ value measured at other temperature must be adjusted to VZ (25 °C)

*2 VZ guaranteed 20 ms after current flow.

*3 Tj = 25 °C to 150 °C