

SSI PROGRAMMABLE MULTITURN ABSOLUTE ENCODER, PHM9 RANGE



- Heavy Duty version, Ø 11 or 12 mm shaft diameter
- Robustness and excellent resistance to shocks / vibrations
- High protection level IP66
- High performances in temperature -20°C to +85°C
- Isolated SSI interface, clock from 100 to 500 kHz
- Universal electronic circuits from 5 to 30Vdc
- Protection against short-circuits and inversion of polarity
- High resolutions available : 8192 (13 bits) per turn
- Turn counting up to 65 536 (16 bits)
- 2 inputs : DIRECTION and RAZ
- Type choice of the wished limit value : position, rotation speed, temperature
- Diagnostic functions: temperature, rotation speed, position, input/output level
- Programming of the encoder with a serial transmission RS232 directly with the serial PC connection: resolution, number of turn, output code, parity, SSI frame bit number, reset value, functions of the 2 outputs: (OUT1 and OUT2): limit switch, incremental channels



RS232



PHM9_12 connection P6R (radial M23)

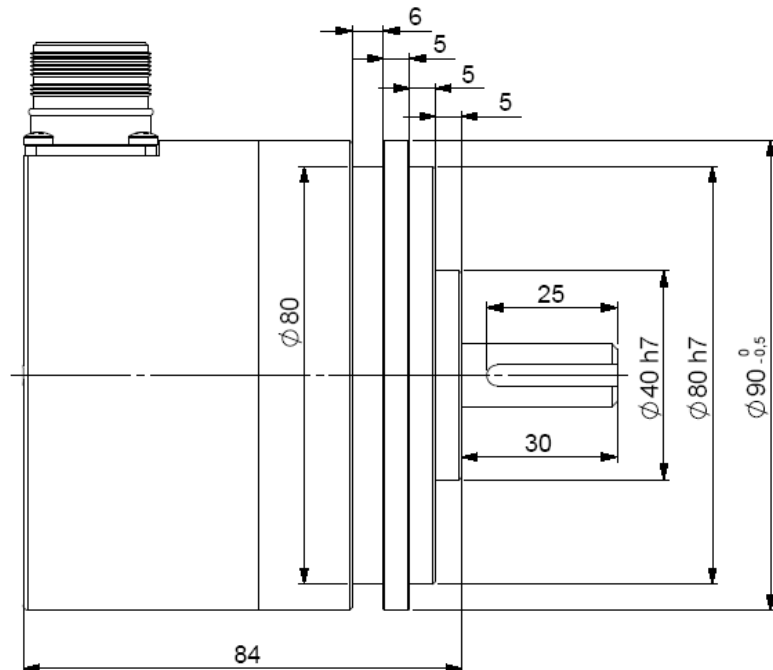
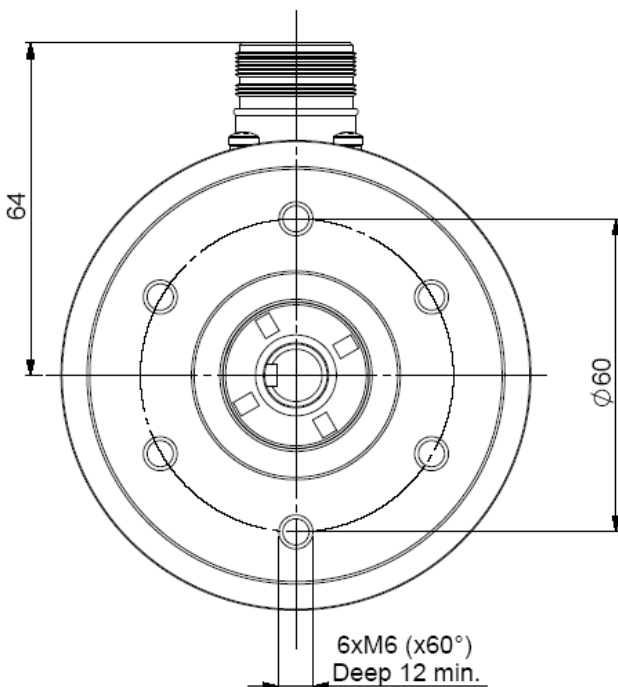

CHARACTERISTICS

Material	Cover: steel	Shocks (EN60068.2.27)	≤ 500m.s ² (during 6 ms)	
	Body: aluminium	Vibrations (EN60068.2.6)	≤ 100m.s ² (10 ... 2 000 Hz)	
Shaft	Stainless steel	EMC	EN 61000-6-4, EN 61000-6-2	
Bearings	6001 serie	Isolation	100V (1 min.)	
Maximal loads	Axial: 100 N	Encoder weight (approx.)	1,600 kg	
	Radial: 200 N	Operating temperature	- 20 ... + 85 °C (encoder T ^P)	
Shaft inertia	≤ 15.10 ⁻⁶ kg.m ²	Storage temperature	- 20 ... + 85 °C	
Torque	≤ 10.10 ⁻³ N.m	Protection (EN 60529)	IP 66	
Permissible max. speed	6 000 min ⁻¹	Theoretic al mechanical life time 10 ⁹ turns (F _{axial} / F _{radial})		
Continuous max. speed	6 000 min ⁻¹			
Shaft seal	Viton double lips	20 N / 30 N	50 N / 100 N	100 N / 200 N
		360	18	2,2

SSI PROGRAMMABLE MULTITURN ABSOLUTE ENCODER, PHM9 RANGE

In order to optimize the installation times of SSI encoders, BEI DEACOD has developed a friendly software, easy to use, with which it's possible to program your encoder under WINDOWS in only 2 minutes. With a simple connection to the serial connector of your PC, you can:

- configure : the number of points per revolution, the number of turns, the code type, SSI frame bit number, the parity, reset value
- read : type of selected encoder, the serial number of the encoder, the position of the encoder, the temperature, the speed of rotation, the level of the input/output
- save the chosen configuration, load saved configurations
- function of the outputs and limit value : position, speed of rotation, temperature, incremental channels 2048 ppr

ELECTRICAL CHARACTERISTIC

Input signal clock CLK	per opto-coupleur	Power supply	5 – 30Vdc
Output signal DATA	line - driver selon RS422	Introduction	< 1 s
Clock frequency CLK	100kHz – 500kHz	Cons. without load	< 100mA (typically 60-70mA at 24Vdc)
Precision	± ½ LSB (13 bits)	Position refresh	< 200µs

SSI TRANSMISSION

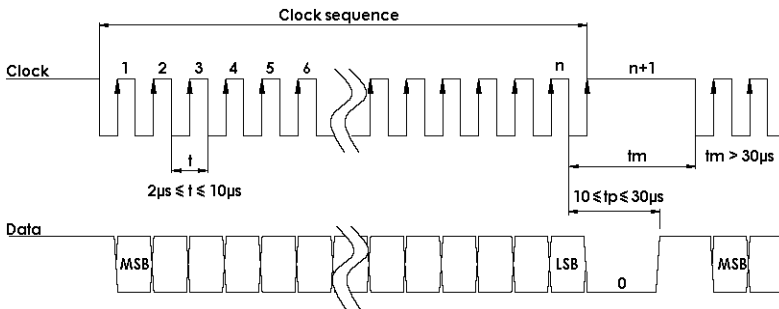

Transmission	Transmission up to 400m* at 100kHz in function of the cable characteristics
Cable	High security of transmission by using shielded cable and twisted pairs

* consult us for length > 100m

SSI CONNECTION

Type	Vcc	Gnd	Clk+	Data+	RAZ	Data-	Clk-	DIR	OUI1	OUI2	TXD Encoder RXD RS232	RXD Encoder TXD RS232
P6	1	2	3	4	5	6	7	9	10	11	8	12

The pinouts TXD and RXD entries used for the encoder programming
Connect the entry DIRECTION and RAZ to a potential (RAZ to the 0V if not used)

Data output RS422

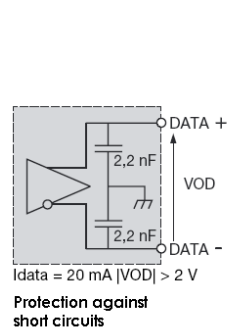

Isolated Clk input

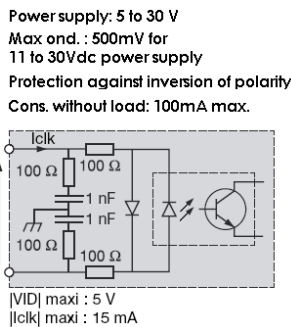

DIRECTION input

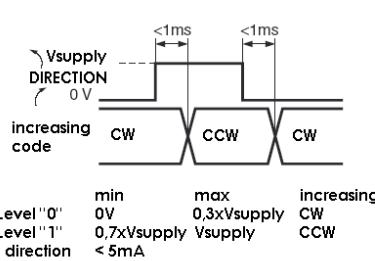

RAZ / RAX input

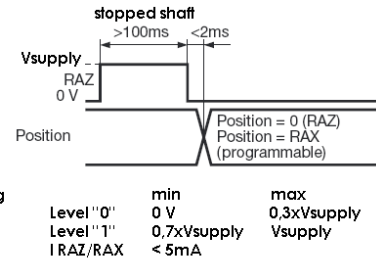

- Output :**
- Max current: 20mA
 - Level "0" max : 0.5V, Level "1" min : $V_{supply} - 2,5\text{V}$
 - Limit switch time answer : < 400µs
 - Incremental channels : 100kHz max

Programming cable : PC RS232

- Supply : 230Vac / 12Vdc
 - Cable Sub D9 (serial PC) / M23 12 pins (encoder)
- Reference : PRO-020S001**

ORDERING REFERENCE (Contact the factory for special versions, ex: special flanges, connections, electronic s...)

	Shaft Ø	Supply	Output stage	Code	Resolution			Connection	Orientation
PHM9_	11:11mm 12:12mm	P: 5 to 30Vdc	PX : SSI programmable Nota : without parity by default	G : Gray default	13 B12 D5			P6: M23 12pins CW for SSI transmission	R: radial
					Resolution	Nb of turn	Nb data		
					13: 13 bits default	B12: 12 bits default	D5: 25 bits default		
PHM9_	10 //	P	PX	G //	13	B12	D5 //	P6	R

SOFTWARE/ CONFIGURATION MANUAL : consult us

Made in FRANCE