

The HS22 series of hollow shaft incremental encoder offers application advantages over conventional optical encoders. This heavy duty unit is designed for ease of installation to a servo motor, the encoder's flexible coupling fits over the driven motor shaft to provide an accurate, backlash-free method of attachment.



The mounting method eliminates the need for couplings, sprockets, or gearing. The integral flex mount provides for a 20-degree angular adjustment. Through-shaft or blind shaft configurations of the HS22 encoder are available.

Through-shaft units allow for applications where the center of the encoder must be used for transmission of fluids, cabling, or optics. Blind shaft units are designed to mate with shaft lengths of 0.50 to 1.50 inch. Standard outputs for both configurations include: A and B in quadrature with index and optional commutation signals for brushless motor control.

## Mechanical Specifications

- Shaft Bore:** 0.500" (standard) 0.375", 0.250", 10mm, 8mm and 6mm available
- Allowable Misalignment:** 0.010 T.I.R. on mating shaft
- Bore Runout:** 0.001" T.I.R.
- Starting Torque at 25°C:** 5-in-oz (max)
- Bearings:** 52100 SAE high carbon steel
- Shaft Material:** 303 stainless steel
- Bearing Housing:** Die cast aluminum with protective finish
- Cover:** Drawn aluminum with protective finish
- Bearing Life:** 7.5 X 10<sup>9</sup> revs (50, 000 hrs at 2500 RPM)
- Maximum RPM:** 5,000 RPM
- Moment of Inertia:** 10 X 10<sup>-4</sup> oz-in-sec<sup>2</sup>
- Weight:** 10 oz (max)

## Electrical Specifications

- Code:** Incremental Output Format, 2 channels in quadrature, one cycle (nominal) ungated index (other index options and commutation channels available—consult factory).
- Cycles Per Shaft Turn:** 100 to 2540
- Supply Voltage:** 5, 12–15, 24–28 VDC
- Current Requirements:** 120 mA typical, 175 mA max
- Voltage/Output:** (see note 5)  
28V/V: Line Driver, 5–28 VDC in, V<sub>out</sub> = V<sub>in</sub>  
28V/5: Line Driver, 5–28 VDC in, V<sub>out</sub> = 5 VDC  
28V/OC: Open Collector, 5–28 VDC in, OC<sub>out</sub>
- Protection Level:** Output short circuit
- Frequency Response:**  
100kHz allowable operating speed (RPM) = (100kHz/Resolution) x 60
- Output Termination Pinouts:** See table 1, back page

## Environmental Specifications

- Enclosure Rating:** NEMA 5 (IP50) for through shaft versions (TS) and NEMA 12 (IP52) for blind shaft (BS) versions
- Temperature: Operating,** 0° to 70° C; extended temperature testing available, -40° to 85° ; storage, -20° to 90° C.
- Shock:** 50 g's for 11 msec duration
- Vibration:** 5 to 2000 Hz @ 10 g's
- Humidity:** 98% RH non-condensing

**NOTES AND TABLES:** All notes and tables referred to in the text can be found on the back page.

## HS22 Incremental Ordering Options FOR ASSISTANCE CALL 800-350-2727

Use this diagram, working from left to right to construct your model number (example: HS22F-50-R1-TS-256-ABZC-28V/V-SC18).

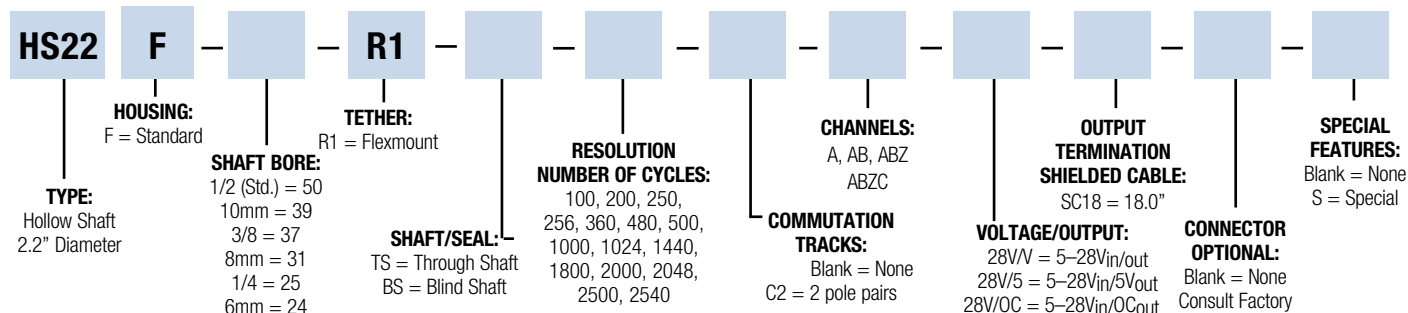

## Dimensions

HS22 Diagram

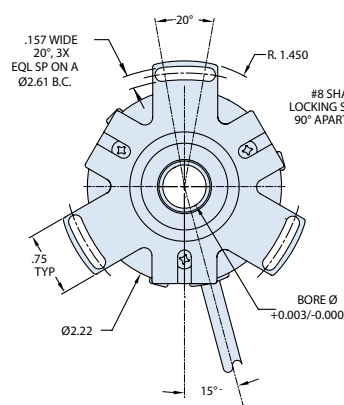

Thru Shaft

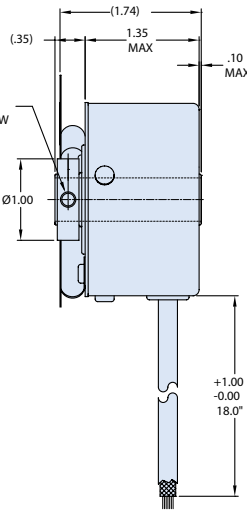

Blind Shaft

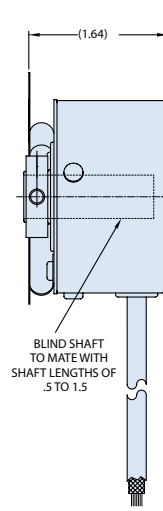
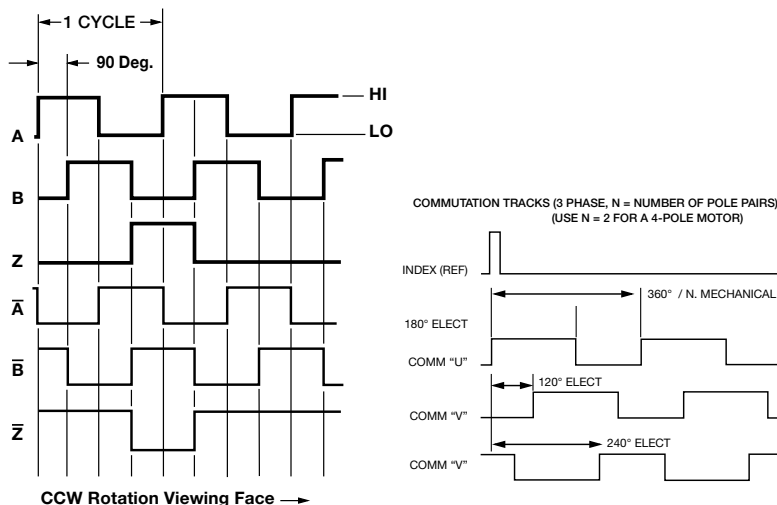

Table 1

### Output Termination Pinouts

STANDARD INCREMENTAL OUTPUTS		OPTION COMMUTATION OUTPUTS	
COLOR	FUNCTION	COLOR	FUNCTION
YEL	A	GRY	U
WHT/YEL	$\bar{A}$	WHT/YGRY	$\bar{U}$
BLU	B	BRN	V
WHT/BLU	$\bar{B}$	WHT/BRN	$\bar{V}$
ORN	Z	VIO	W
WHT/ORN	$\bar{Z}$	WHT/VIO	$\bar{W}$
RED	+V (SUPPLY)		
BLK	0 V (GROUND)		
GRN	CASE GROUND		

Figure 1 Output Waveform



## Notes

- Mounting is usually done either using the D-style square flange mount, E- or G-style servo mounts, or one of the standard face mounts, F1 for example. Consult factory for additional face mount options.
- The shaft seal is recommended in virtually all installations. The most common exceptions are applications requiring a very low starting torque or those requiring operation at both high temperature and high speed.
- Non-standard index widths and multiple indices are available by special order. Consult factory.
- Complementary outputs are recommended for use with line driver type (source/sink) outputs. When used with differential receivers, this combination provides a high degree of noise immunity.
- Output IC's:** Output IC's are available as either Line Driver (LD) or NPN Open Collector (OC) types. Open Collectors require pull-up resistors, resulting in higher output source impedance (sink impedance is similar to that of line drivers). In general, use of a Line Driver style output is recommended. Line Drivers source or sink current and their lower impedance mean better noise immunity and faster switching times. **Warning:** Do not connect any line driver outputs directly to circuit common/OV, which may damage the driver. Unused outputs should be isolated and left floating. Our applications specialists would be pleased to discuss your system requirements and the compatibility of your receiving electronics with Line Driver type outputs.
- 28V/V:** Multi-voltage Line Driver (7272\*): 100 mA source/sink. Input voltage 5 to 28 VDC +/- 5% standard (Note:  $V_{out} = V_{in}$ ). This driver is TTL compatible when used with 5 volt supply. Supply lines are protected against overvoltage to 60 volts and reverse voltage. Outputs are short circuit protected for one minute. Supply current is 120 mA typical (plus load current). This is the recommended replacement for 3904R and 7406R open collector outputs with internal pullup resistors. It is also a direct replacement for any 4469, 88C30, 8830 or 26LS31 line driver
- 28V/5:** Multi-voltage Line Driver (7272\*): 100 mA source/sink. Input voltage 5 to 28 VDC +/- 5% standard, internally regulated with 5V (TTL compatible) logic out. Supply lines are protected against overvoltage to 60 volts and reverse voltage. Outputs are short circuit protected for one minute. Supply current is 90 mA typical (plus load current).
- 15V/V:** Multi-voltage Line Driver (4469\*): 100 mA source/sink. Input voltage 5 to 15 VDC +/- 5% standard (Note:  $V_{out} = V_{in}$ ). TTL compatible when used with 5 volt supply. Supply lines are protected against overvoltage to 60 volts and reverse voltage. Outputs are short circuit protected for one minute. Supply current is 90 mA typical (plus load current). This is a direct replacement for the 4469 Line Driver.
- 28V/OC:** NPN Open Collector (3904\*, 7273\*). Current sink of 80 mA max. Current sourced by external pull-up resistor. Output can be pulled up to voltage other than supply voltage (30 V max). Input voltage 5 to 28 VDC +/- 5% standard. Supply current is 120 mA typical. This replaces prior IC's with designations of 3904, 7406, 3302, 681 and 689.
- 5V/OCR, 15V/OCR, 24V/OCR:** Open Collector (3904R\*, 7406R\*, 7273R\*): Current sink of 70 mA max. Includes internal pull-ups sized at approximately 100 ohms/volt. Max current source is 10 mA. Supply current is 100 mA typical, 120 mA with internal pull-ups. The 5V/OCR, 15V/OCR and 24V/OCR are often replaced by the 28V/V in system upgrades.
- 3904, 3904R, 4469, 5V/V, 5V/OC, 5V/OCR, 9V/OC:** Intrinsically safe line driver and open collector outputs. These drivers are specific to intrinsically safe encoders, and are installed per the appropriate control drawings listed in Table 2.1 on page 48 of the 2008 BEI Spec Guide.
- Special -S at the end of the model number is used to define a variety of non-standard features such as special shaft lengths, voltage options, or special testing. Please consult the factory to discuss your special requirements.
- Higher frequency response may be available. Please consult with the factory.
- Extended temperature ratings are available in the following ranges: -40 to 70°C, -40 to 85°C, -20 to 105°C and -40 to 105°C depending on the particular model. Some models can operate down to -55°C. Extended temperature ranges can affect other performance factors. Consult with factory for more specific information.
- Mating straight plug receptacles may be ordered from the factory: For M12 use MS3116F12-10S, For M14 use MS3106F14S-6S For M14/19 use MS3116J14-19S, For M16 use MS3106F16S-1S For M18 use MS3106F18-1S, For M20 use MS3106F20-29S