

# BEI SENSORS

## T-SERIES INDUSTRIAL INCLINOMETER

### CANopen INTERFACE



T-Series industrial inclinometers are compact high performance sensors used to determine inclination in roll and pitch axes with excellent precision and at a high value. Whether using a molded plastic housing or an AW6082-T6 aluminum alloy housing, both versions offer mechanical stability and an encapsulated sensor. Both have a high environmental protection rating making them ideal for measuring tilt in harsh industrial environments.

#### Main Features

- Dual Axis Measurement Range up to  $\pm 60^\circ$
- Option for a Single Axis Measurement Range of  $360^\circ$
- High Resolution:  $0.01^\circ$
- High Accuracy:  $0.1^\circ$
- Glass Fiber Reinforced Plastic Housing available
- Factory Calibrated Linearity
- Temperature Compensated for Bias and Sensitivity
- Interface: CANopen
- Highest Protection Class: IP69K, IP68

#### Programmable Parameters

- Resolution, Preset, Baud Rate, Software Filters

#### Electrical Features

- Latest MEMS Technology for High Precision and Dynamics
- Reverse Polarity Protection
- Over Voltage Peak Protection
- Termination Resistor

#### Applications

- Measurement of Inclination (pitch and roll) and Rotational Movements
- Cranes and Construction Machines
- Robotic Arms & Positioning Systems
- Mobile Platform stabilization
- Marine & Offshore Machinery

#### Model Ordering Options

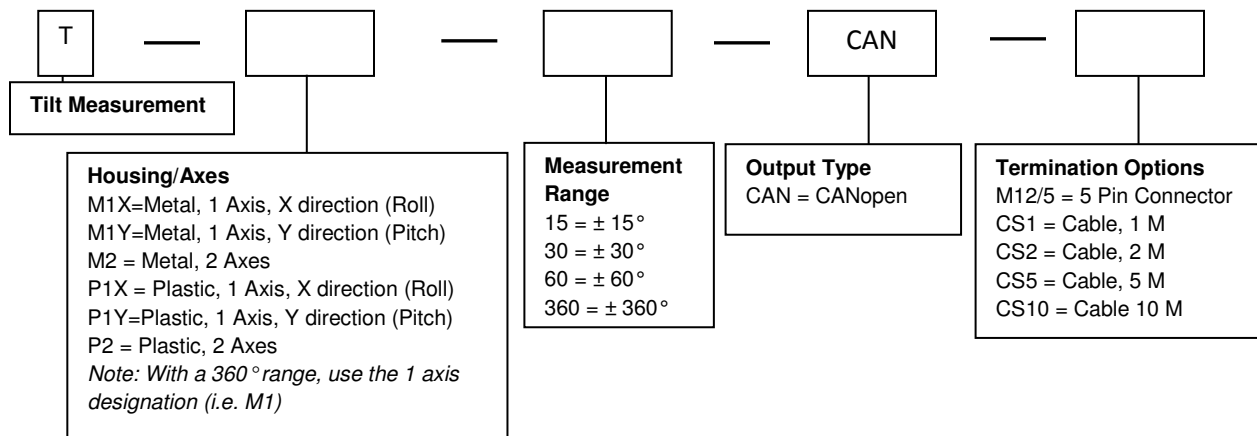

# BEI SENSORS

## Electrical Data

Model	T- M2 (or P2)- (Range)			T-M1 (or P1) - 360
	15	30	60	
<b>Measurement Range</b>	± 15°	± 30°	± 60	360°
<b>Number of Axes</b>	2 (Standard), 1 optional			1
<b>Resolution</b>	0.01°			
<b>Accuracy (T = -10 °C to +40 °C)</b>	0.1°			
<b>Sensor Response Time</b>	10 ms (Without Filter)			
<b>Recommended Measurement Rate</b>	Up to 10 Hz			
<b>Interface</b>	CANopen (In Conformance to DS410) Transceiver According ISO 11898, Galvanically Isolated by Opto-Couplers			
<b>Transmission Rate</b>	Adjustable: Max. 1 MBaud (Factory Setting : 125 kBaud)			
<b>Addressing</b>	Programmable Node-id from 1 to 127 (Factory Setting: 1)			
<b>Supply Voltage</b>	10 to 30 V DC (Absolute Maximum Ratings)			
<b>Current Consumption</b>	Max. 57 mA at 10 V DC; Max. 53 mA at 24 V DC			
<b>EMC</b>	Emitted Interference: EN 61000-6-4			
<b>Current Consumption</b>	Noise Immunity: EN 61000-6-2			
<b>Connection Connector</b> ACS- .... - PM	5 Pin M5 male (A-coded)			
<b>Connection Cable</b> ACS- .... – DW-...	Ø 7.1 mm [0.28 in] Polyurethane: 4 x 2 x 0.34 mm <sup>2</sup> [AWG 22]			

## Mechanical Data

<b>Housing Material (Plastic)</b>	Glass Fiber Reinforced PBT (Polybutylene Terephthalate)
<b>Housing Material (Metal)</b>	AW6082 Corrosion resistant Aluminum alloy, passivated
<b>Potting Material</b>	PUR (Polyurethane)
<b>Shock (EN 60068-2-27)</b>	≤ 100 g (half sine, 6 ms)
<b>Vibration (EN 60068-2-6)</b>	1.5mm (10 to 58 Hz) & ≤ 20 g (58 to 2000 Hz)
<b>Weight</b>	170 gm / 6 oz

## Environmental Conditions

<b>Operating Temperature</b>	-40 °C to +85 °C / -40 °F to 185 °F
<b>Humidity</b>	98 % Relative Humidity, Non-Condensing
<b>Protection Class (EN 60529)</b>	IP 69K (With Appropriate Mating Connector and mounting), IP68, IP67

## Programmable Parameters

<b>Resolution per 1°</b>	The resolution parameter per 1° is used to program the desired number (1°, 0.1° and 0.01°) of steps per 1°.
<b>Preset Value</b>	The Preset value is the desired position value, which should be reached at a certain physical position of the axis. The position value is set to the desired process value by the preset parameter.
<b>Moving Average-Filter</b>	This filter can be used to adjust the bandwidth of measuring values to minimize the influence of vibration. Factory Setting: Moving average filter activated for 20 subsequent readouts.
<b>Digital Recursive Filter</b>	This filter can be used for weighting the last measured value with the last previous value. This is useful to suppress sudden peaks in the angle measurement.
<b>Transmission Rate</b>	Adjustable - Min. 20 kBaud; Max. 1 MBaud Factory Setting : 125 kBaud
<b>Address (Node ID)</b>	Adjustable from 1 to 127 Factory setting: Node ID=1



## Programmable CAN Transmission Modes

<b>Polled Mode</b>	By a remote-transmission-request telegram, the connected host calls for the current process value. The inclinometer reads the current position value, calculates set parameters and sends back the calculated process value by the same identifier.
<b>Cyclic Mode</b>	The inclinometer transmits cyclically the current process value, without being called by the host. The cycle time can be programmed in milliseconds for values between 1 ms and 65536 ms.
<b>Sync Mode</b>	The inclinometer answers with current process value after receiving a sync telegram. The parameter sync counter can be programmed to skip a certain number of sync telegrams before answering again.
<b>Heartbeat Function</b>	A node signals its communication status by cyclically transmitting a heartbeat message. This message is received by one or any number of members (Heartbeat Consumers) in the bus and so they can control the dedicated node (Heartbeat Producer).

## Mechanical Drawings

Plastic-housed unit (P1, P2)

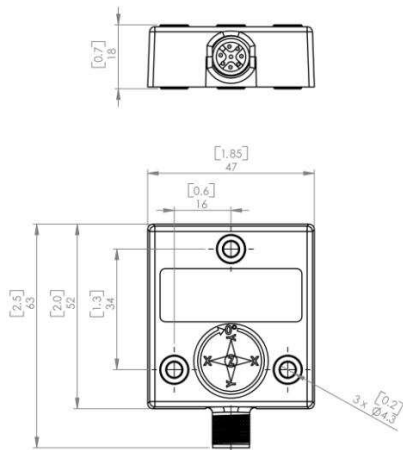

Metal-housed unit (M1, M2)

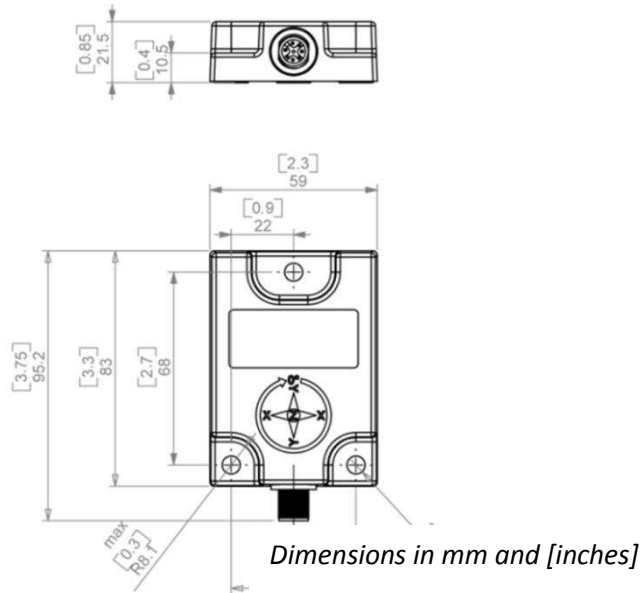

## Measurement Axes (Two Axis Units)

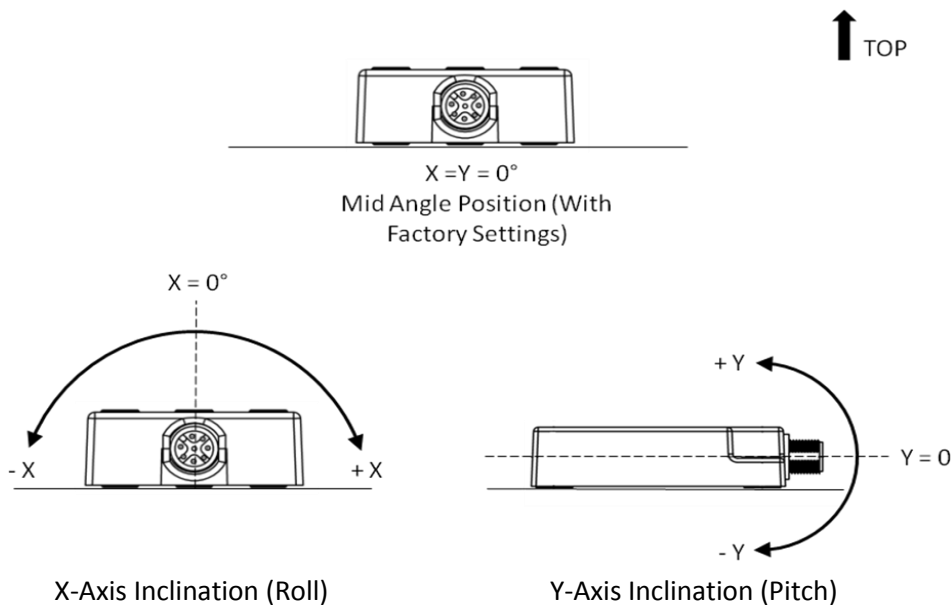

## Measurement Axis - 360 (Single Axis Inclinometer)

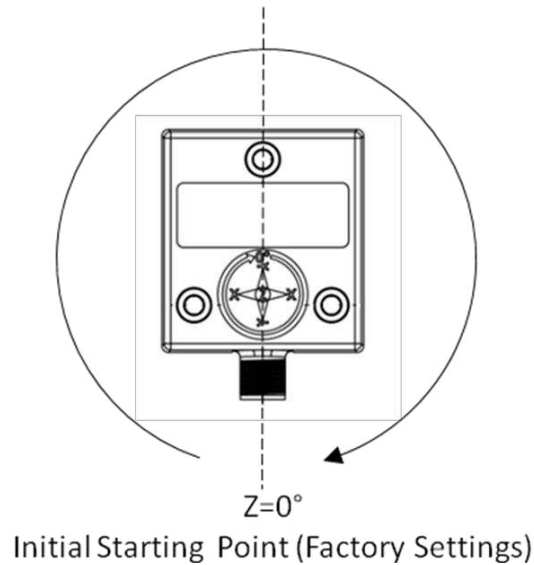

## Pin Assignment

The inclinometer is connected via a 5 pin M12 A-coded round connector or cable exit.  
(Standard M12, Male side at sensor, Female at connector counterpart or connection cable)

Signal	5 pin M12 connector	Cable Exit
CAN Ground	1	Green
+Vs Supply Voltage	2	Red
0 V Supply voltage	3	Yellow
CAN High	4	White
CAN Low	5	Brown

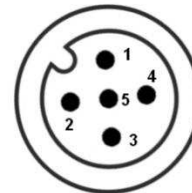

## CANopen Output

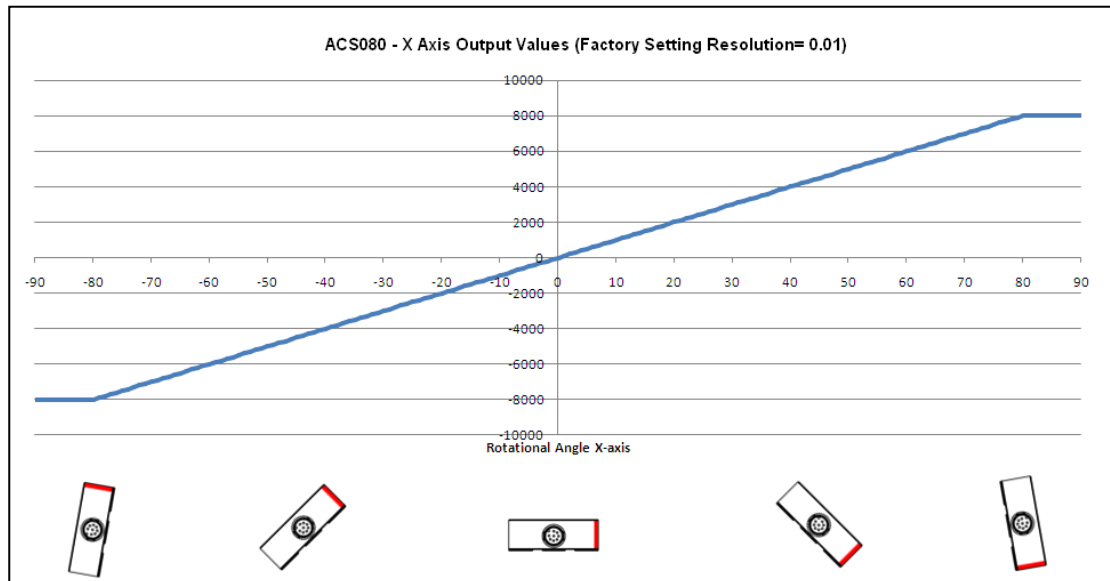
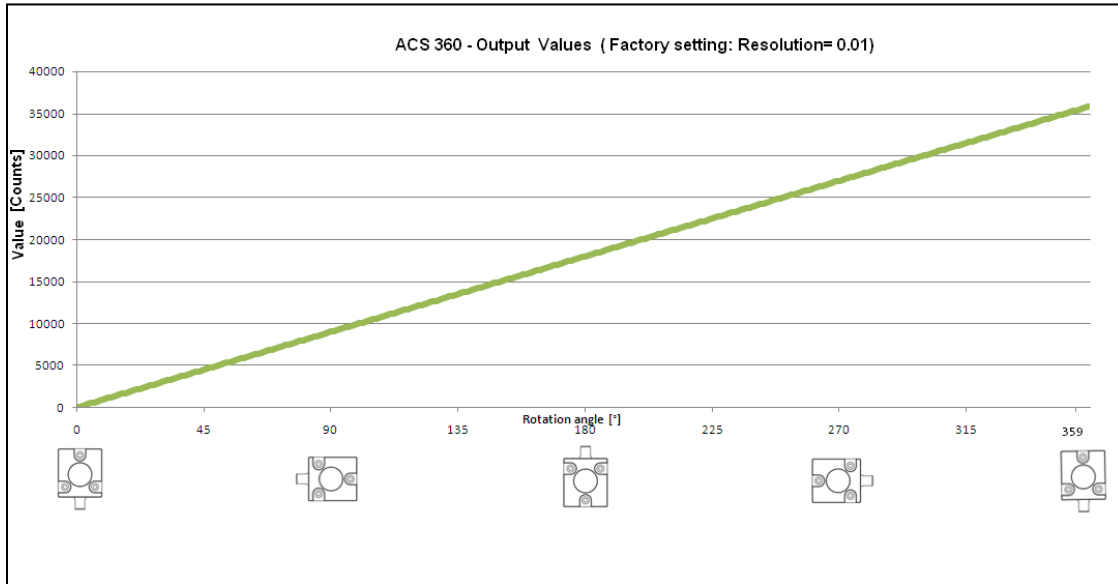

# BEI SENSORS

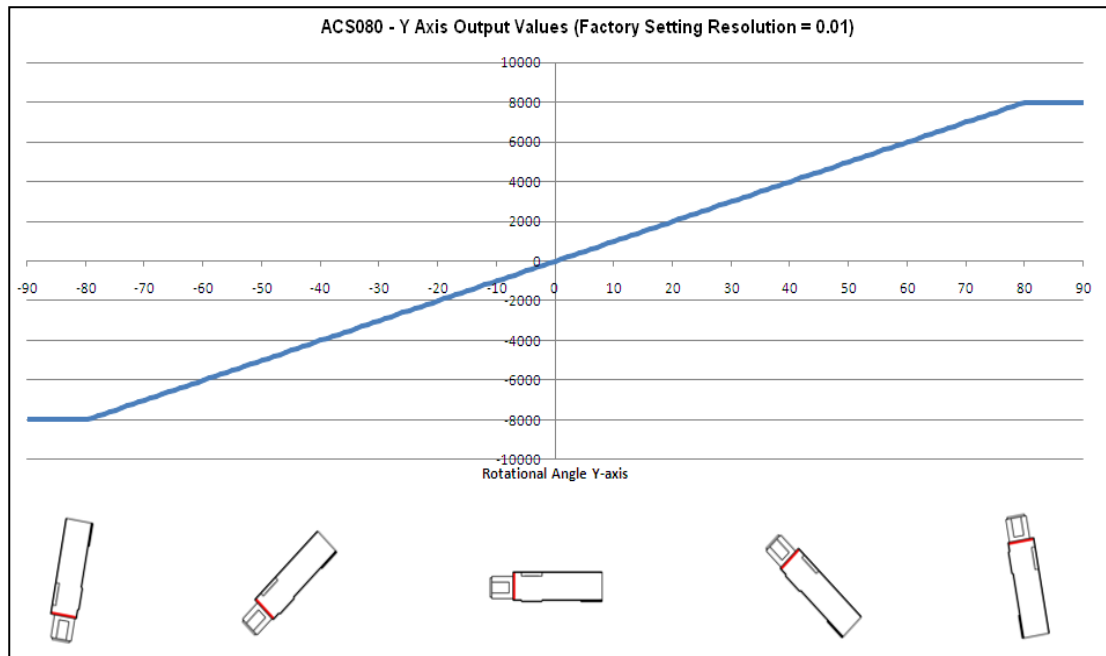

## Disclaimer

© BEI Sensors all rights reserved. We do not assume responsibility for technical inaccuracies or omissions. Specifications are subject to change without notice.

**North** 7230 Hollister Ave, Goleta CA 93117 USA  
**America:** Tel: 805-968-0782 | beisales@beisensors.com

**Europe:** Espace Européen de l'Entreprise, 9, rue de Copenhague, B.P. 70044 Schiltigheim, F 67013  
Strasbourg Cedex FRANCE; Tél : +33 (0)3 88 20 80 80 | info@beisensors.com

Specification No. 02139-002 REV D

[www.beisensors.com](http://www.beisensors.com)